



BA157G THRU BA159G

1.0 AMP. Glass Passivated Fast Recovery Rectifiers



Voltage Range
400 to 1000 Volts
Current
1.0 Ampere

Features

- ◇ Low forward voltage drop
- ◇ High current capability
- ◇ High reliability
- ◇ High surge current capability

Mechanical Data

- ◇ Cases: DO-41 Molded plastic
- ◇ Epoxy: UL 94V-0 rate flame retardant
- ◇ Lead: Axial leads, solderable per MIL-STD-202, Method 208 guaranteed
- ◇ Polarity: Color band denotes cathode end
- ◇ High temperature soldering guaranteed: 260°C/10 seconds/.375", (9.5mm) lead lengths at 5 lbs., (2.3kg) tension
- ◇ Weight: 0.34 gram

DO-41

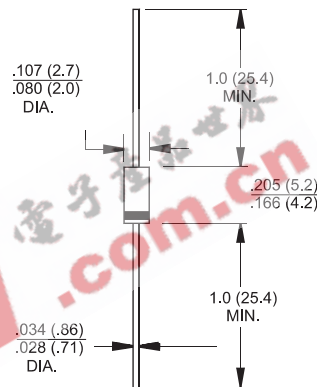

Dimensions in inches and (millimeters)

Maximum Ratings and Electrical Characteristics

Rating at 25°C ambient temperature unless otherwise specified.

Single phase, half wave, 60 Hz, resistive or inductive load.

For capacitive load, derate current by 20%

Type Number	Symbol	BA157G	BA158G	BA159G	Units
Maximum Recurrent Peak Reverse Voltage	V_{RRM}	400	600	1000	V
Maximum RMS Voltage	V_{RMS}	280	420	700	V
Maximum DC Blocking Voltage	V_{DC}	400	600	1000	V
Maximum Average Forward Rectified Current .375" (9.5mm) Lead Length @ $T_A = 45^\circ\text{C}$	$I_{(AV)}$	1.0			A
Peak Forward Surge Current, 8.3 ms Single Half Sine-wave Superimposed on Rated Load (JEDEC method)	I_{FSM}	30			A
Maximum Instantaneous Forward Voltage @ 1.0A	V_F	1.2			V
Maximum DC Reverse Current @ $T_A=25^\circ\text{C}$ at Rated DC Blocking Voltage @ $T_A=100^\circ\text{C}$	I_R	5.0 100			uA uA
Maximum Reverse Recovery Time (Note 1)	T_{rr}	150		250	nS
Typical Junction Capacitance (Note 2)	C_j	15			pF
Typical Thermal Resistance (Note 3)	$R\theta_{JA}$	60			$^\circ\text{C/W}$
Operating Temperature Range	T_J	-65 to +150			$^\circ\text{C}$
Storage Temperature Range	T_{STG}	-65 to +150			$^\circ\text{C}$

Notes: 1. Reverse Recovery Test Conditions: $I_F=0.5A$, $I_R=1.0A$, $I_{RR}=0.25A$

2. Measured at 1 MHz and Applied Reverse Voltage of 4.0 Volts D.C.

3. Mount on Cu-Pad Size 5mm x 5mm on P.C.B.



RATINGS AND CHARACTERISTIC CURVES (BA157G THRU BA159G)

FIG.1- MAXIMUM FORWARD CURRENT DERATING CURVE

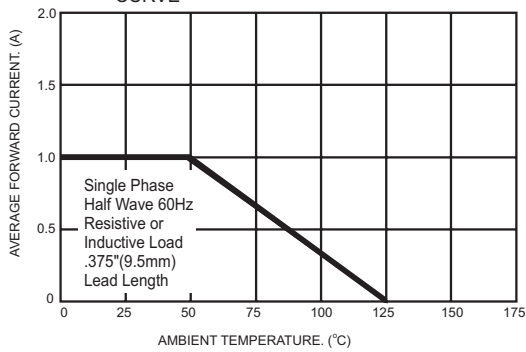

FIG.2- MAXIMUM NON-REPETITIVE PEAK FORWARD SURGE CURRENT

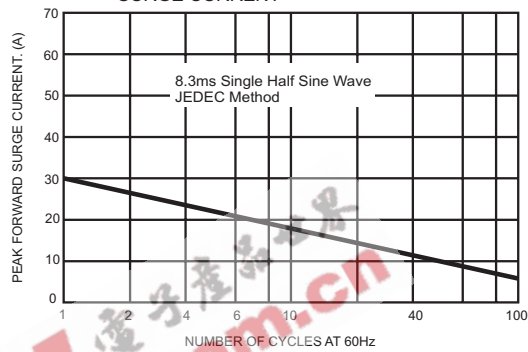

FIG.3- TYPICAL FORWARD CHARACTERISTICS

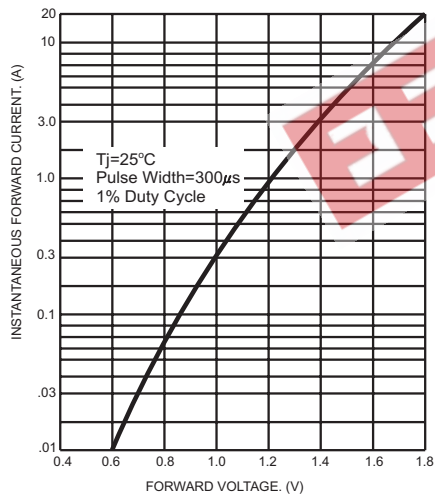

FIG.4- TYPICAL JUNCTION CAPACITANCE

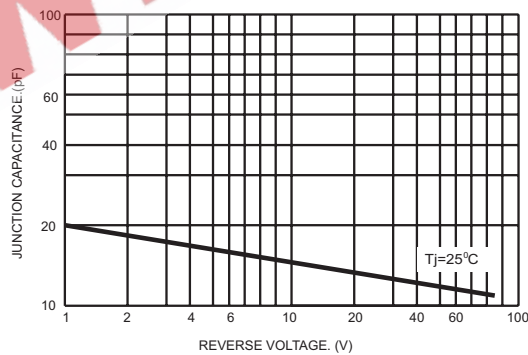

FIG.5- REVERSE RECOVERY TIME CHARACTERISTIC AND TEST CIRCUIT DIAGRAM

