

IN-PHASE 4-WAY DIVIDERS/COMBINERS, POWER SMA/TYPE N 0.5-18 GHz

SERIES YF MODEL D418M

GENERAL SPECIFICATIONS

Frequency Range:	0.5 to 18.0 GHz
RF Impedance:	50 Ohms
RF Power:	The power handling capability for load VSWR 's less than 1.50 is 1 watt CW and 1 kW peak for frequencies up to 2.0 GHz, and 400 mW CW and 0.4 kW peak for frequencies from 2.0 GHz to 18.0 GHz.
Operating Temperature:	-55°C to +85°C
Connectors:	SMA or Type N Female

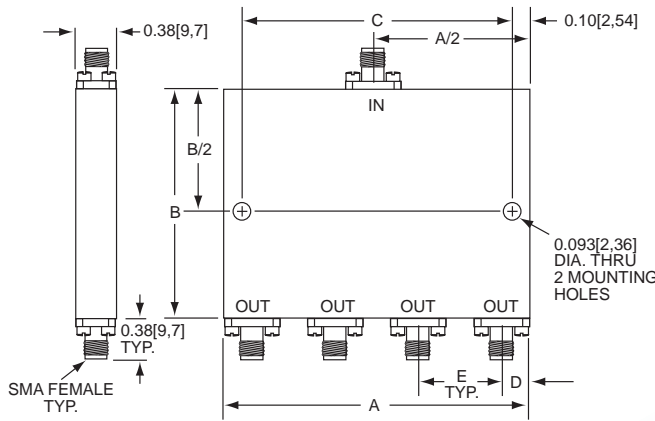

FIGURE 1 SERIES YF

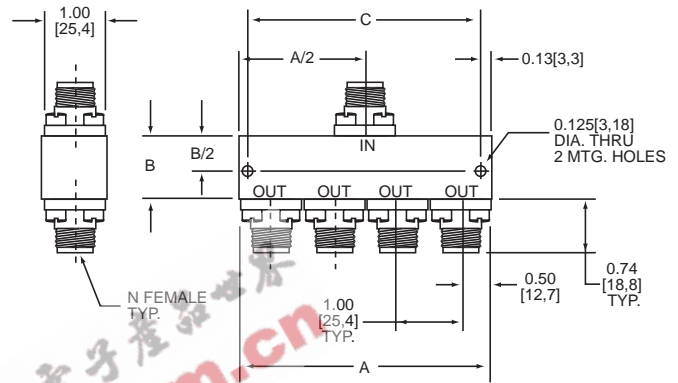

FIGURE 2 SERIES YF-N

Out-line	A in [mm]	B in [mm]	C in [mm]	D in [mm]	E in [mm]
1	2.00 [50,8]	2.25 [57,2]	1.800 [45,72]	0.25 [6,4]	0.50 [12,7]
2	2.60 [66,0]	2.75 [69,9]	2.400 [60,96]	0.25 [6,4]	0.70 [17,8]
3	2.00 [50,8]	1.75 [44,5]	1.800 [45,72]	0.25 [6,4]	0.50 [12,7]
4	1.60 [40,6]	2.00 [50,8]	1.400 [35,56]	0.20 [5,1]	0.40 [10,2]
5	3.20 [81,3]	2.50 [63,5]	3.000 [76,2]	0.20 [5,1]	0.40 [10,2]
6	1.60 [40,6]	1.50 [38,1]	1.400 [35,56]	0.20 [5,1]	0.40 [10,2]
7	4.00 [101,6]	1.75 [44,5]	3.750 [95,25]	—	—
8	4.00 [101,6]	2.75 [69,9]	3.750 [95,25]	—	—
9	4.00 [101,6]	1.25 [31,8]	3.750 [95,25]	—	—
10	4.00 [101,6]	2.00 [50,8]	3.750 [95,25]	—	—
11	4.00 [101,6]	1.00 [25,4]	3.750 [95,25]	—	—
12	Drawing on Request				

ELECTRICAL PERFORMANCE

4 WAY TYPE

Model No.	Type *	Frequency Range GHz	Maximum In/Out VSWR	Maximum Insertion Loss dB	Minimum Isolation dB	Phase Balance Degrees	Amplitude Balance dB	Out-line SMA	Out-line N
YF-23	YF-23N	0.5-1.0	1.25/1.20	0.5	20	3	0.3	1	7
YF-25	YF-25N	0.75-1.5	1.25/1.20	0.5	20	3	0.3	2	8
YF-51	YF-51N	0.5-2.0	1.40/1.30	1.0	18**	4	0.4	2	8
YF-28	YF-28N	1.0-2.0	1.30/1.20	0.5	20	3	0.3	3	7
YF-54	YF-54N	1.0-4.0	1.45/1.35	1.0	18	4	0.4	4	9
YF-30	YF-30N	1.5-3.0	1.30/1.20	0.6	20	3	0.3	5	7
YF-38	YF-38N	2.0-4.0	1.30/1.20	0.8	18	3	0.3	6	7
YF-55	YF-55N	2.0-8.0	1.50/1.40	1.2	16	5	0.5	1	10
YF-45	YF-45N	4.0-8.0	1.40/1.30	1.0	18	5	0.5	6	11
D418M	—	1.0-1.5	1.80/1.35	0.7	10	1	0.2	12	—
		1.5-2.0	1.80/1.35	0.8	14	2	0.2		
		2.0-4.0	1.80/1.45	1.0	17	4	0.3		
		4.0-8.0	1.80/1.45	1.2	17	6	0.4		
		8.0-12.0	1.70/1.45	1.4	17	10	0.5		
		12.0-16.0	1.70/1.45	1.8	15	13	0.6		
		16.0-18.0	1.80/1.45	2.0	12	15	0.6		

* Units with Type N connectors: up to 4GHz multiply VSWR's by 1.05 and subtract 2 dB from isolation. Above 4GHz multiply VSWR's by 1.10 and subtract 3dB from isolation.

** Greater than 30 dB over most of the frequency band.

KE YInches[Millimeters] .XX ±.03 .XXX ±.010 [.X ±0.8 .XX ±0.25]



60 South Jefferson Road, Whippany, NJ 07981
Tel: 973-887-8100 • Fax: 973-884-0445
E-Mail: kdisales@aol.com
See us on the web @ www.kditriangle.com

4 WAY

DIVIDER/COMBINERS, POWER

ELECTRICAL SPECIFICATIONS

Model:	D354KS
Connectors:	Type N
Frequency Range:	860-900 MHz
VSWR:	1.30:1 Maximum
Isolation:	20 dB Minimum
Insertion Loss:	6.5 dB Maximum
RF Power:	50mW Maximum into each port
Amplitude Balance:	±0.3 dB Maximum
Phase Balance:	±3.0° Maximum
Operating Temperature:	-30° C to +70° C

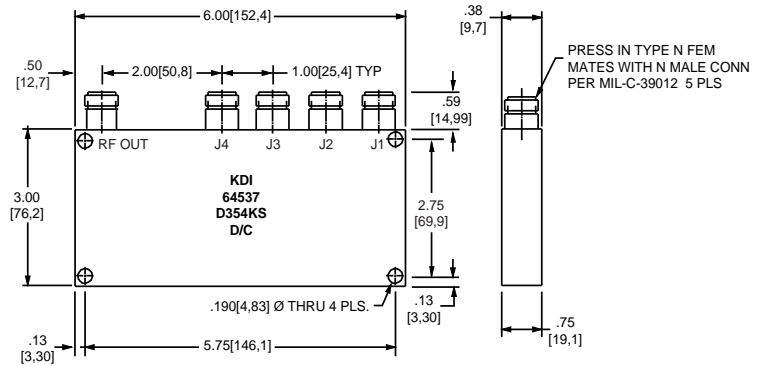

ELECTRICAL SPECIFICATIONS

Model:	D349LS
Connectors:	SMA
Frequency Range:	800-900 MHz
VSWR:	1.3:1 Maximum
Isolation:	20 dB Minimum
Insertion Loss:	0.5 dB Maximum
RF Power:	50mW Maximum into each port
Amplitude Balance:	±1 dB Maximum
Phase Balance:	±2.0° Maximum
Operating Temperature:	-30° C to +70° C

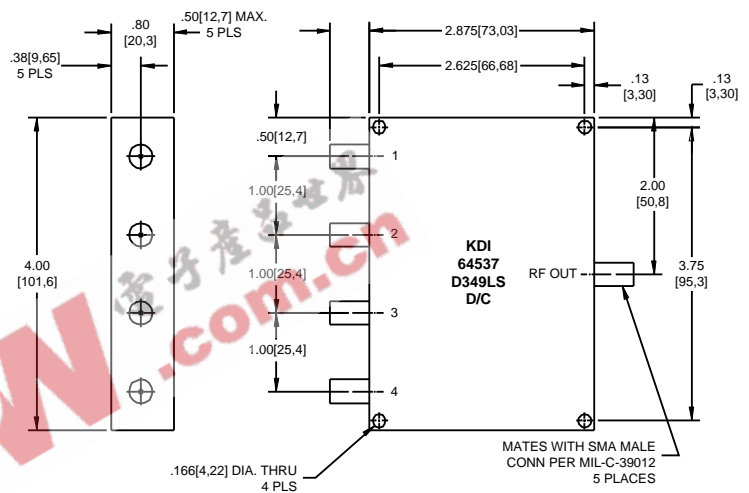

ELECTRICAL SPECIFICATIONS

Model:	D307MS
Connectors:	SMA
Frequency Range:	824-925 MHz
VSWR:	1.2:1 Maximum
Isolation:	20 dB Minimum
Insertion Loss:	6.3 dB Maximum (inc. div. loss)
Amplitude Balance:	±0.1 dB Maximum
Phase Balance:	±2° Maximum
RF Power:	4.0 Watts CW Total @ Input
Operating Temperature:	-30° C to +70° C

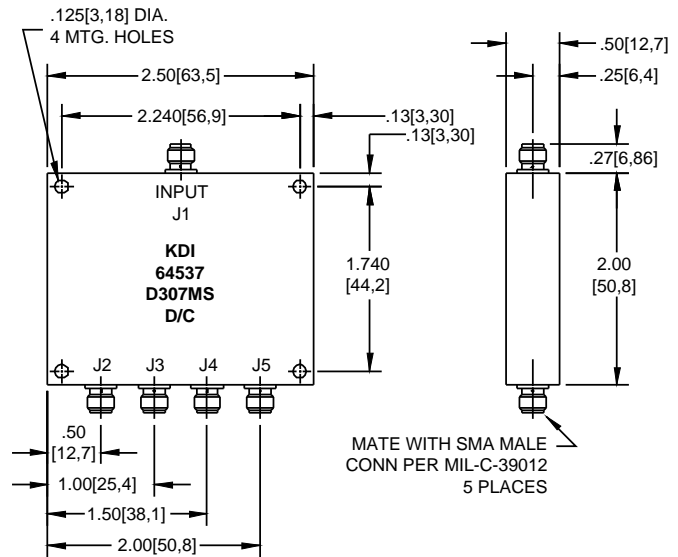

KE Y Inches [Millimeters] .XX ±.03 .XXX ±.010 [.X ±0.8 .XX ±0.25]



KDI / TRIANGLE
An MCE Company CORPORATION

60 South Jefferson Road, Whippany, NJ 07981
Tel: 973-887-8100 • Fax: 973-884-0445
E-Mail: kdisales@aol.com
See us on the web @ www.kditriangle.com

4 WAY

DIVIDER/COMBINERS, POWER

ELECTRICAL SPECIFICATIONS

Model:	D331MS
Connectors:	Type N
Frequency Range:	800-960 MHz
VSWR:	Out 2.0:1 Maximum—unterminated input 1.6:1 Maximum—terminated input
Isolation:	15 dB Minimum output to input 20 dB Minimum output to output
Insertion Loss:	-8.0 dB Maximum (incl. divide loss)
RF Power:	2 Watts Maximum
Amplitude Balance:	±0.5 dB Maximum
Phase Balance:	±2° Maximum
Operating Temperature:	-30° to +70°C

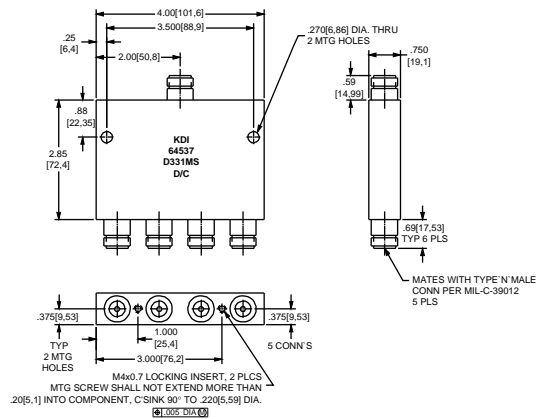

GENERAL INFORMATION

The Model D366KS includes an equal four way power divider with Type N input and 4 SMA outputs. An isolated monitor port directional coupler with a BNC output connector is provided with a closely calibrated 20dB coupling value. Stripline construction and KDI high power Beryllium Oxide resistors employed in the design can readily be adapted to new custom applications.

ELECTRICAL SPECIFICATIONS

Model:	D366KS
Connectors:	See Outline
Frequency Range:	800-900 MHz
VSWR:	1.35:1 Maximum
INS Loss:	6.6 dB Maximum
Isolation:	24.0 dB Minimum J2-J3, J4-J5 -40 dB Minimum (Coupler) J1-J6 29 dB Minimum All Other Combiner Combinations
Coupling:	-20 ± .5 dB
Amplitude Balance:	±0.5 dB Maximum
Phase Balance:	±2° Maximum
RF Power:	2 Watts Maximum
Operating Temperature:	-30° to +70°C

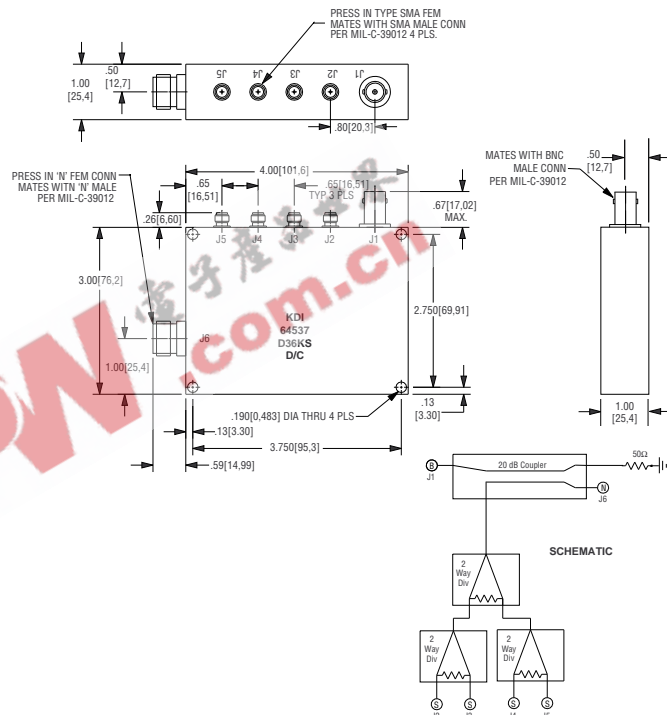

ELECTRICAL SPECIFICATIONS

Model:	D317NS
Connectors:	SMA
Frequency Range:	800-2000 MHz
Insertion Loss:	1.2 Maximum above 6 dB
Isolation:	30 dB typ. 23 dB Minimum
VSWR:	In: 1.25 Maximum typ. Out: 1.15 Maximum typ.
Amplitude Balance:	0.3 dB Maximum
Phase Balance:	±2° Maximum
RF Power:	+20 dBm Maximum
Operating Temperature:	-30° to +70°C
Housing Material:	Metalized Plastic

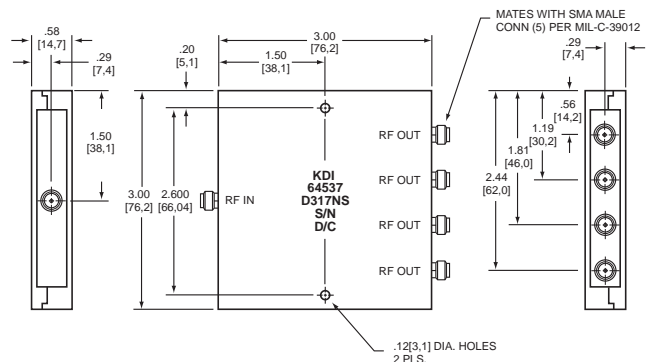

KE Y Inches [Millimeters] .XX ±.03 .XXX ±.010 [.X ±0.8 .XX ±0.25]



60 South Jefferson Road, Whippany, NJ 07981
Tel: 973-887-8100 • Fax: 973-884-0445
E-Mail: kdisales@aol.com
See us on the web @ www.kditriangle.com

6 WAY DIVIDERS/COMBINERS, POWER

ELECTRICAL SPECIFICATIONS

Model:	D315MS
Connectors:	SMA
Frequency Range:	800-900 MHz
VSWR:	1.3:1 Maximum
Isolation:	24 dB Minimum
Insertion Loss:	15.5 dB \pm 0.25 dB
RF Power:	30 dBm Maximum @ (J1) Port
Amplitude Balance:	\pm 0.5 dB Maximum
Phase Balance:	\pm 3° Maximum
Operating Temperature:	-30° to +70°C

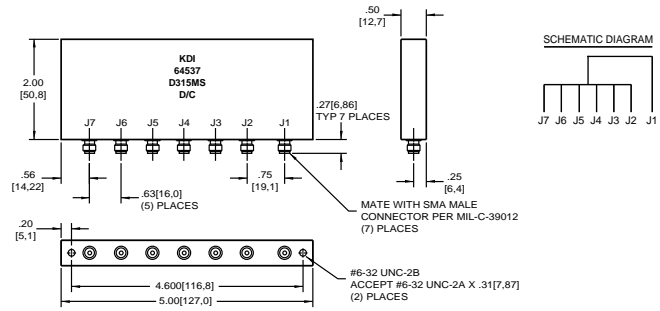

ELECTRICAL SPECIFICATIONS

Model:	D365MS
Connectors:	SMA
Frequency Range:	400-2000 MHz
Insertion Loss above 7.8 dB:	1.5 dB
Isolation:	14 dB Minimum
VSWR:	1.35:1 Maximum
RF Power:	1 Watt Maximum @ Input Port 100 milliwatts Maximum/Port as a Combiner
Amplitude Balance:	\pm 0.7 dB Maximum
Phase Balance:	\pm 5° Maximum
Operating Temperature:	-30° to +70°C

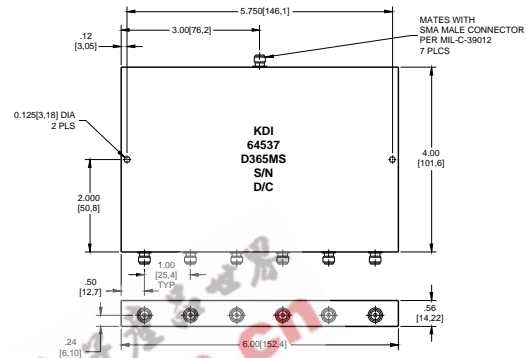

ELECTRICAL SPECIFICATIONS

Model:	D308MS
Connectors:	SMA
Frequency Range:	824-925 MHz
VSWR:	1.2:1 Maximum
Isolation:	20 dB Minimum
Insertion Loss:	8.2 dB Maximum (incl. div. loss)
RF Power:	4.0 Watts CW Total @ input
Amplitude Balance:	\pm 0.5 dB Maximum
Phase Balance:	\pm 3° Maximum
Operating Temperature:	-30° to +70°C

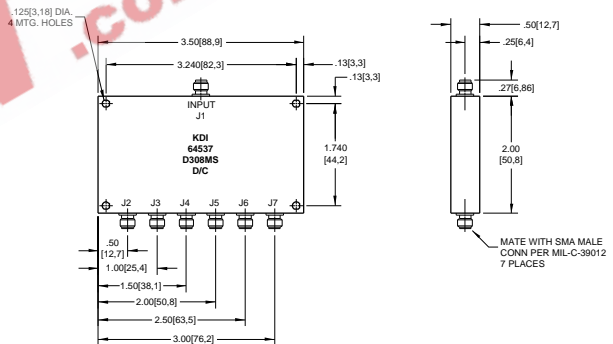

ELECTRICAL SPECIFICATIONS

Model:	D357KS
Connectors:	Type N
Frequency Range:	800-960 MHz
VSWR:	1.35:1 Maximum all ports
Isolation:	20.0 dB Minimum
Insertion Loss:	9.0 dB Maximum (incl. divide loss)
RF Power:	5 W Maximum
Amplitude Balance:	\pm 0.5 dB Maximum
Phase Balance:	\pm 3° Maximum
Operating Temperature:	-30° to +70°C

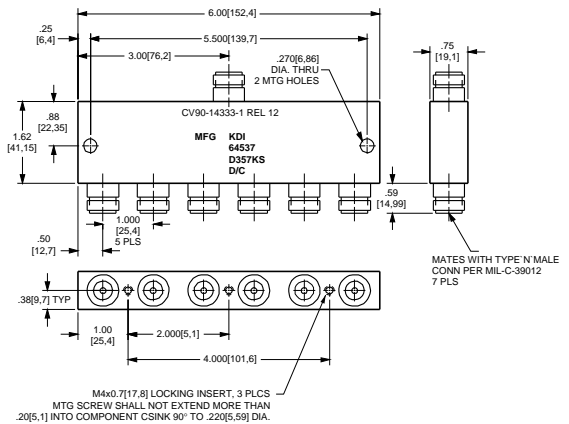

KEY: Inches[Millimeters] .XX \pm .03 .XXX \pm .010 [.X \pm 0.8 .XX \pm 0.25]



60 South Jefferson Road, Whippany, NJ 07981
Tel: 973-887-8100 • Fax: 973-884-0445
E-Mail: kdisales@aol.com
See us on the web @ www.kditriangle.com

6 WAY

DIVIDERS/COMBINERS, POWER SUBASSEMBLY—WITH VARIABLE ATTENUATORS

GENERAL INFORMATION

The Model D387LS power divider subassembly incorporates unique level set adjustable attenuators, each with a minimum adjustment range of 0-12dB. Resistor isolated Wilkinson power dividers provide for high isolation between signal paths, and include a power monitor function. The stripline construction provided throughout can be readily modified for other custom applications.

ELECTRICAL SPECIFICATIONS

Model:	D387LS
Connectors:	Type N Output SMA Input BNC Monitor Port
Frequency Range:	0.865 – 0.900 GHz
Insertion Loss:	14.5 ±0.5 dB at 0 dB Trim 3.0 +5 –0 dB
Attenuator Trim:	0 to 12 dB Minimum (Screwdriver)
RF Power:	+17 dBm
Isolation:	20 dB Minimum at 0 dB Trim
VSWR (All Ports):	1.60:1 Maximum
Operating Temperature:	-30° to +70°C.

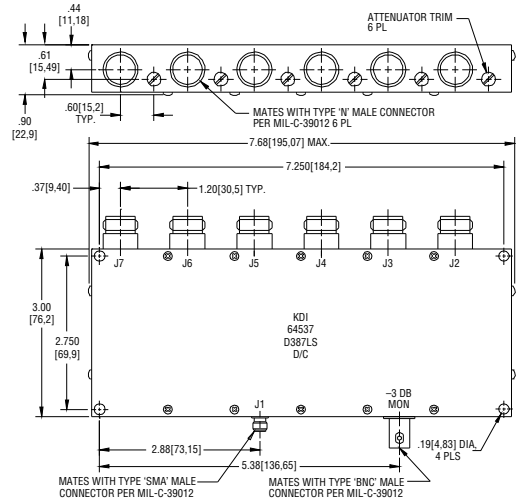
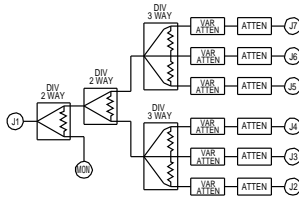

ELECTRICAL SPECIFICATIONS

Model:	D390MS
Connectors:	SMA/N
Frequency Range:	824-894 MHz
VSWR:	1.2:1 Maximum
Isolation:	20.0 dB Minimum
Insertion Loss:	8.5 dB Maximum (Includes divide loss)
RF Power:	500 milliwatts Maximum @ Combined Port
Amplitude Balance:	±0.2 dB Maximum
Phase Balance:	±0.2 Maximum
Operating Temperature:	-30° to +70°C.

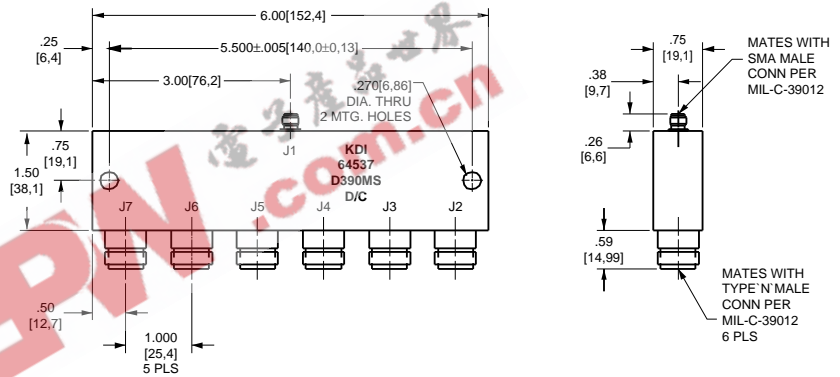

ELECTRICAL SPECIFICATIONS

Model:	D333KS
Frequency:	.860-.900 GHz
VSWR:	1.35:1 Maximum
Isolation:	>27 dB J5-J6 (J1, J2, J3, J4 & J7 Open) 20 dB Minimum all other
Insertion Loss:	12.0 ± .4 dB (J7-J1, J7-J2)
Coupling:	10.0 ± .5 dB (J5-J1)
Path Loss:	4.5 dB Maximum (4.1 dB Typical) (J7-J6)
RF Power:	50mW Maximum each input
Operating Temperature:	-30° to +70°C.

Port Designations above indicate (RF OUT — RF IN)

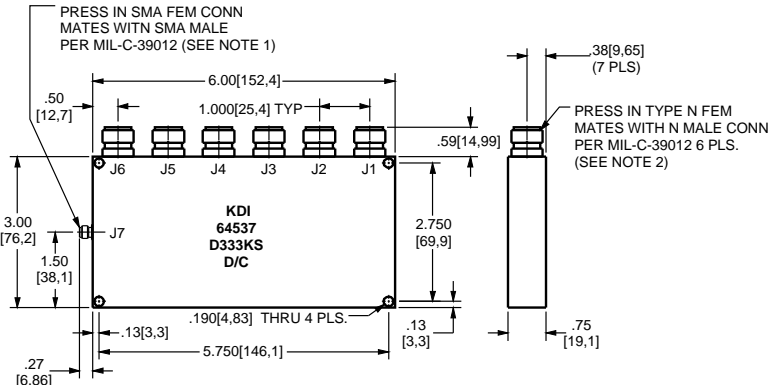

Notes:

1. Connector SMA: Passivated Stainless Steel ASTM-A-582 (QQ-S-764) Body with Gold Plated (MIL-G-45204 Type II, Class I, Grade C)
2. Connector N: Nickel Plated (QQ-N-290) over CU. Strike (MIL-C-14550) over Brass Body 1/2 HD Comp 22 (QQ-B-626)
3. HSG: Chem Film (MIL-C-5541) Class 1A over Aluminum 6061-T6 per (QQ-A-250)

KEY: Inches[Millimeters] .XX ±.03 .XXX ±.010 [.X ±0.8 .XX ±0.25]



60 South Jefferson Road, Whippany, NJ 07981
 Tel: 973-887-8100 • Fax: 973-884-0445
 E-Mail: kdisales@aol.com
 See us on the web @ www.kditriangle.com