

KA78MXX

3-Terminal 0.5A Positive Voltage Regulator

Features

- Output Current up to 0.5A
- Output Voltages of 5, 6, 8, 12, 15, 18, 24V
- Thermal Overload Protection
- Short Circuit Protection
- Output Transistor Safe Operating Area (SOA) Protection

Description

The KA78MXX series of three terminal positive regulators are available in the TO-220/D-PAK package with several fixed output voltages making it useful in a wide range of applications.

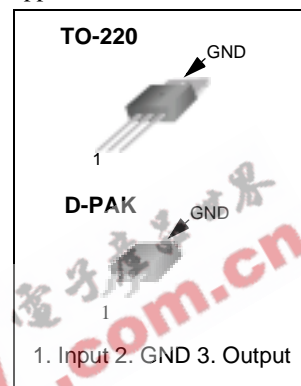

Internal Block Diagram

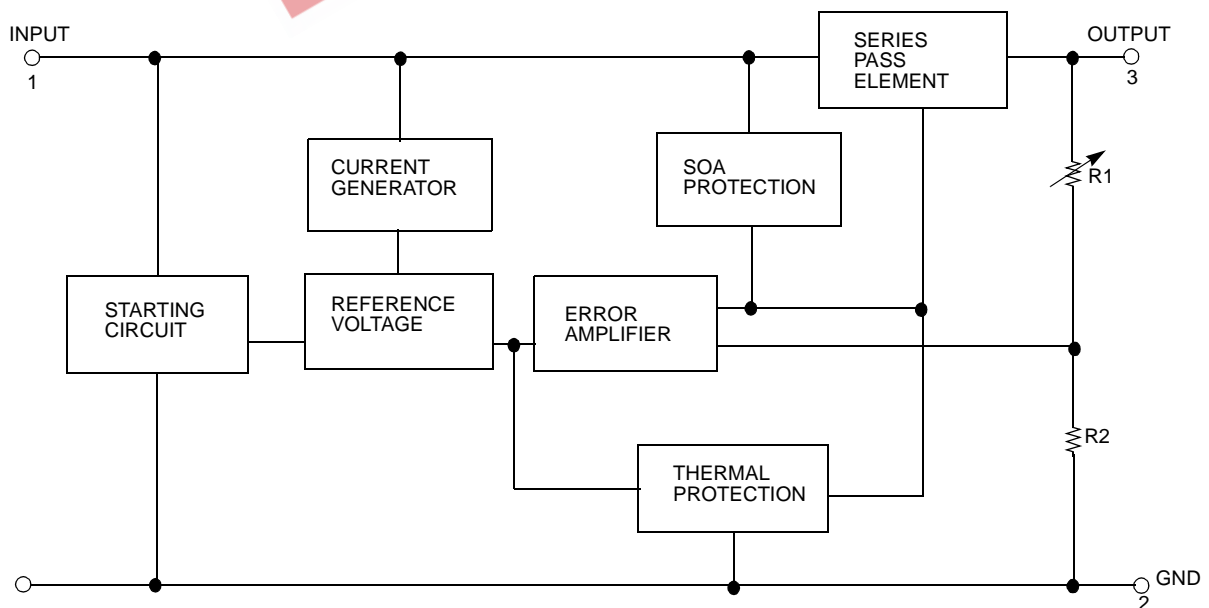

Absolute Maximum Ratings

Parameter	Symbol	Value	Unit
Input Voltage (for $V_O = 5V$ to $18V$) (for $V_O = 24V$)	V_I	35	V
	V_I	40	V
Thermal Resistance Junction-Cases (Note1) TO-220 ($T_c = +25^\circ\text{C}$)	$R_{\theta JC}$	2.5	$^\circ\text{C/W}$
Thermal Resistance Junction-Air (Note1,2) TO-220 ($T_a = +25^\circ\text{C}$) D-PAK ($T_a = +25^\circ\text{C}$)	$R_{\theta JA}$	66	$^\circ\text{C/W}$
		92	
Operating Junction Temperature Range	TOPR	0 ~ +150	$^\circ\text{C}$
Storage Temperature Range	TSTG	-65 ~ +150	$^\circ\text{C}$

Note:

- Thermal resistance test board
Size: 76.2mm * 114.3mm * 1.6mm(1S0P)
JEDEC standard: JESD51-3, JESD51-7
- Assume no ambient airflow

Electrical Characteristics (KA78M05/KA78M05R)

(Refer to the test circuits, $0 \leq T_J \leq +125^\circ\text{C}$, $I_O = 350\text{mA}$, $V_I = 10\text{V}$, unless otherwise specified, $C_I = 0.33\mu\text{F}$, $C_O = 0.1\mu\text{F}$)

Parameter	Symbol	Conditions	Min.	Typ.	Max.	Unit	
Output Voltage	V_O	$T_J = +25^\circ\text{C}$	4.8	5	5.2	V	
		$I_O = 5$ to 350mA $V_I = 7$ to 20V	4.75	5	5.25		
Line Regulation (Note3)	ΔV_O	$I_O = 200\text{mA}$ $T_J = +25^\circ\text{C}$	$V_I = 7$ to 25V	-	-	100	mV
			$V_I = 8$ to 25V	-	-	50	
Load Regulation (Note3)	ΔV_O	$I_O = 5\text{mA}$ to 0.5A , $T_J = +25^\circ\text{C}$		-	-	100	mV
		$I_O = 5\text{mA}$ to 200mA , $T_J = +25^\circ\text{C}$		-	-	50	
Quiescent Current	I_Q	$T_J = +25^\circ\text{C}$	-	4.0	6.0	mA	
Quiescent Current Change	ΔI_Q	$I_O = 5\text{mA}$ to 350mA		-	-	0.5	mA
		$I_O = 200\text{mA}$ $V_I = 8$ to 25V		-	-	0.8	
Output Voltage Drift	$\Delta V/\Delta T$	$I_O = 5\text{mA}$ $T_J = 0$ to $+125^\circ\text{C}$		-	-0.5	-	mV/ $^\circ\text{C}$
Output Noise Voltage	V_N	$f = 10\text{Hz}$ to 100kHz		-	40	-	$\mu\text{V}/V_O$
Ripple Rejection	RR	$f = 120\text{Hz}$, $I_O = 300\text{mA}$ $V_I = 8$ to 18V , $T_J = +25^\circ\text{C}$		-	80	-	dB
Dropout Voltage	V_D	$T_J = +25^\circ\text{C}$, $I_O = 500\text{mA}$		-	2	-	V
Short Circuit Current	I_{SC}	$T_J = +25^\circ\text{C}$, $V_I = 35\text{V}$		-	300	-	mA
Peak Current	I_{PK}	$T_J = +25^\circ\text{C}$		-	700	-	mA

Note:

- Load and line regulation are specified at constant junction temperature. Change in V_O due to heating effects must be taken into account separately. Pulse testing with low duty is used.

Electrical Characteristics (KA78M06/KA78M06R) (Continued)(Refer to the test circuits, $0 \leq T_J \leq +125^\circ\text{C}$, $I_O=350\text{mA}$, $V_I=11\text{V}$, unless otherwise specified, $C_I=0.33\mu\text{F}$, $C_O=0.1\mu\text{F}$)

Parameter	Symbol	Conditions	Min.	Typ.	Max.	Unit
Output Voltage	V_O	$T_J = +25^\circ\text{C}$	5.75	6	6.25	V
		$I_O = 5$ to 350mA $V_I = 8$ to 21V	5.7	6	6.3	
Line Regulation (Note1)	ΔV_O	$I_O = 200\text{mA}$ $T_J = +25^\circ\text{C}$	-	-	100	mV
		$V_I = 8$ to 25V $V_I = 9$ to 25V	-	-	50	
Load Regulation (Note1)	ΔV_O	$I_O = 5\text{mA}$ to 0.5A , $T_J = +25^\circ\text{C}$	-	-	120	mV
		$I_O = 5\text{mA}$ to 200mA , $T_J = +25^\circ\text{C}$	-	-	60	
Quiescent Current	I_Q	$T_J = +25^\circ\text{C}$	-	4.0	6.0	mA
Quiescent Current Change	ΔI_Q	$I_O = 5\text{mA}$ to 350mA	-	-	0.5	mA
		$I_O = 200\text{mA}$ $V_I = 9$ to 25V	-	-	0.8	
Output Voltage Drift	$\Delta V/\Delta T$	$I_O = 5\text{mA}$ $T_J = 0$ to $+125^\circ\text{C}$	-	-0.5	-	mV/ $^\circ\text{C}$
Output Noise Voltage	V_N	$f = 10\text{Hz}$ to 100kHz	-	45	-	$\mu\text{V}/V_O$
Ripple Rejection	RR	$f = 120\text{Hz}$, $I_O = 300\text{mA}$ $V_I = 9$ to 19V , $T_J = +25^\circ\text{C}$	-	80	-	dB
Dropout Voltage	V_D	$T_J = +25^\circ\text{C}$, $I_O = 500\text{mA}$	-	2	-	V
Short Circuit Current	I_{SC}	$T_J = +25^\circ\text{C}$, $V_I = 35\text{V}$	-	300	-	mA
Peak Current	I_{PK}	$T_J = +25^\circ\text{C}$	-	700	-	mA

Note:

1. Load and line regulation are specified at constant, junction temperature. Change in V_O due to heating effects must be taken into account separately. Pulse testing with low duty is used.

Electrical Characteristics (KA78M08/KA78M08R) (Continued)(Refer to the test circuits, $0 \leq T_J \leq +125^\circ\text{C}$, $I_O=350\text{mA}$, $V_I=14\text{V}$, unless otherwise specified, $C_I=0.33\mu\text{F}$, $C_O=0.1\mu\text{F}$)

Parameter	Symbol	Conditions	Min.	Typ.	Max.	Unit	
Output Voltage	V_O	$T_J = +25^\circ\text{C}$	7.7	8	8.3	V	
		$I_O = 5$ to 350mA $V_I = 10.5$ to 23V	7.6	8	8.4		
Line Regulation (Note1)	ΔV_O	$I_O = 200\text{mA}$ $T_J = +25^\circ\text{C}$	$V_I = 10.5$ to 25V	-	-	100	mV
			$V_I = 11$ to 25V	-	-	50	
Load Regulation (Note1)	ΔV_O	$I_O = 5\text{mA}$ to 0.5A , $T_J = +25^\circ\text{C}$	-	-	160	mV	
		$I_O = 5\text{mA}$ to 200mA , $T_J = +25^\circ\text{C}$	-	-	80		
Quiescent Current	I_Q	$T_J = +25^\circ\text{C}$	-	4.0	6.0	mA	
Quiescent Current Change	ΔI_Q	$I_O = 5\text{mA}$ to 350mA	-	-	0.5	mA	
		$I_O = 200\text{mA}$ $V_I = 10.5$ to 25V	-	-	0.8		
Output Voltage Drift	RR	$I_O = 5\text{mA}$ $T_J = 0$ to $+125^\circ\text{C}$	-	-0.5	-	mV/ $^\circ\text{C}$	
Output Noise Voltage	V_N	$f = 10\text{Hz}$ to 100kHz	-	52	-	$\mu\text{V}/V_O$	
Ripple Rejection	RR	$f = 120\text{Hz}$, $I_O = 300\text{mA}$ $V_I = 11.5$ to 21.5V , $T_J = +25^\circ\text{C}$	-	80	-	dB	
Dropout Voltage	V_D	$T_J = +25^\circ\text{C}$, $I_O = 500\text{mA}$	-	2	-	V	
Short Circuit Current	I_{SC}	$T_J = +25^\circ\text{C}$, $V_I = 35\text{V}$	-	300	-	mA	
Peak Current	I_{PK}	$T_J = +25^\circ\text{C}$	-	700	-	mA	

Note:

1. Load and line regulation are specified at constant, junction temperature. Change in V_O due to heating effects must be taken into account separately. Pulse testing with low duty is used.

Electrical Characteristics (KA78M12/KA78M12R) (Continued)(Refer to the test circuits, $0 \leq T_J \leq +125^\circ\text{C}$, $I_O=350\text{mA}$, $V_I=19\text{V}$, unless otherwise specified, $C_I=0.33\mu\text{F}$, $C_O=0.1\mu\text{F}$)

Parameter	Symbol	Conditions	Min.	Typ.	Max.	Unit	
Output Voltage	V_O	$T_J = +25^\circ\text{C}$	11.5	12	12.5	V	
		$I_O = 5$ to 350mA $V_I = 14.5$ to 27V	11.4	12	12.6		
Line Regulation (Note1)	ΔV_O	$I_O = 200\text{mA}$ $T_J = +25^\circ\text{C}$	$V_I = 14.5$ to 30V	-	-	100	mV
			$V_I = 16$ to 30V	-	-	50	
Load Regulation (Note1)	ΔV_O	$I_O = 5\text{mA}$ to 0.5A , $T_J = +25^\circ\text{C}$	-	-	240	mV	
		$I_O = 5\text{mA}$ to 200mA , $T_J = +25^\circ\text{C}$	-	-	120		
Quiescent Current	I_Q	$T_J = +25^\circ\text{C}$	-	4.1	6.0	mA	
Quiescent Current Change	ΔI_Q	$I_O = 5\text{mA}$ to 350mA	-	-	0.5	mA	
		$I_O = 200\text{mA}$ $V_I = 14.5$ to 30V	-	-	0.8		
Output Voltage Drift	$\Delta V/\Delta T$	$I_O = 5\text{mA}$ $T_J = 0$ to $+125^\circ\text{C}$	-	-0.5	-	mV/ $^\circ\text{C}$	
Output Noise Voltage	V_N	$f = 10\text{Hz}$ to 100kHz	-	75	-	$\mu\text{V}/V_O$	
Ripple Rejection	RR	$f = 120\text{Hz}$, $I_O = 300\text{mA}$ $V_I = 15$ to 25V , $T_J = +25^\circ\text{C}$	-	80	-	dB	
Dropout Voltage	V_D	$T_J = +25^\circ\text{C}$, $I_O = 500\text{mA}$	-	2	-	V	
Short Circuit Current	ISC	$T_J = +25^\circ\text{C}$, $V_I = 35\text{V}$	-	300	-	mA	
Peak Current	I_{PK}	$T_J = +25^\circ\text{C}$	-	700	-	mA	

Note:

1. Load and line regulation are specified at constant, junction temperature. Change in V_O due to heating effects must be taken into account separately. Pulse testing with low duty is used.

Electrical Characteristics (KA78M15) (Continued)(Refer to the test circuits, $0 \leq T_J \leq +125^\circ\text{C}$, $I_O=350\text{mA}$, $V_I=23\text{V}$, unless otherwise specified, $C_I=0.33\mu\text{F}$, $C_O=0.1\mu\text{F}$)

Parameter	Symbol	Conditions	Min.	Typ.	Max.	Unit
Output Voltage	V_O	$T_J = +25^\circ\text{C}$	14.4	15	15.6	V
		$I_O = 5$ to 350mA $V_I = 17.5$ to 30V	14.25	15	15.75	
Line Regulation (Note1)	ΔV_O	$I_O = 200\text{mA}$ $T_J = +25^\circ\text{C}$	-	-	100	mV
		$V_I = 17.5$ to 30V $V_I = 20$ to 30V	-	-	50	
Load Regulation (Note1)	ΔV_O	$I_O = 5\text{mA}$ to 0.5A , $T_J = +25^\circ\text{C}$	-	-	300	mV
		$I_O = 5\text{mA}$ to 200mA , $T_J = +25^\circ\text{C}$	-	-	150	
Quiescent Current	I_Q	$T_J = +25^\circ\text{C}$	-	4.1	6.0	mA
Quiescent Current Change	ΔI_Q	$I_O = 5\text{mA}$ to 350mA	-	-	0.5	mA
		$I_O = 200\text{mA}$ $V_I = 17.5$ to 30V	-	-	0.8	
Output Voltage Drift	$\Delta V/\Delta T$	$I_O = 5\text{mA}$ $T_J = 0$ to $+125^\circ\text{C}$	-	-1	-	mV/ $^\circ\text{C}$
Output Noise Voltage	V_N	$f = 10\text{Hz}$ to 100kHz	-	100	-	$\mu\text{V}/V_O$
Ripple Rejection	RR	$f = 120\text{Hz}$, $I_O = 300\text{mA}$ $V_I = 18.5$ to 28.5V , $T_J = +25^\circ\text{C}$	-	70	-	dB
Dropout Voltage	V_D	$T_J = +25^\circ\text{C}$, $I_O = 500\text{mA}$	-	2	-	V
Short Circuit Current	I_{SC}	$T_J = +25^\circ\text{C}$, $V_I = 35\text{V}$	-	300	-	mA
Peak Current	I_{PK}	$T_J = +25^\circ\text{C}$	-	700	-	mA

Note:

1. Load and line regulation are specified at constant junction temperature. Change in V_O due to heating effects must be taken into account separately. Pulse testing with low duty is used.

Electrical Characteristics (KA78M18) (Continued)(Refer to the test circuits, $0 \leq T_J \leq +125^\circ\text{C}$, $I_O=350\text{mA}$, $V_I=26\text{V}$, unless otherwise specified, $C_I=0.33\mu\text{F}$, $C_O=0.1\mu\text{F}$)

Parameter	Symbol	Conditions	Min.	Typ.	Max.	Unit
Output Voltage	V_O	$T_J = +25^\circ\text{C}$	17.3	18	18.7	V
		$I_O = 5 \text{ to } 350\text{mA}$ $V_I = 20.5 \text{ to } 33\text{V}$	17.1	18	18.9	
Line Regulation (Note1)	ΔV_O	$I_O = 200\text{mA}$ $T_J = +25^\circ\text{C}$	-	-	100	mV
		$V_I = 21 \text{ to } 33\text{V}$ $V_I = 24 \text{ to } 33\text{V}$	-	-	50	
Load Regulation (Note1)	ΔV_O	$I_O = 5\text{mA} \text{ to } 0.5\text{A}$, $T_J = +25^\circ\text{C}$	-	-	360	mV
		$I_O = 5\text{mA} \text{ to } 200\text{mA}$, $T_J = +25^\circ\text{C}$	-	-	180	
Quiescent Current	I_Q	$T_J = +25^\circ\text{C}$	-	4.2	6.0	mA
Quiescent Current Change	ΔI_Q	$I_O = 5\text{mA} \text{ to } 350\text{mA}$	-	-	0.5	mA
		$I_O = 200\text{mA}$ $V_I = 21 \text{ to } 33\text{V}$	-	-	0.8	
Output Voltage Drift	$\Delta V/\Delta T$	$I_O = 5\text{mA}$, $T_J = 0 \text{ to } 125^\circ\text{C}$	-	-1.1	-	mV/ $^\circ\text{C}$
Output Noise Voltage	V_N	$f = 10\text{Hz} \text{ to } 100\text{kHz}$	-	100	-	$\mu\text{V}/V_O$
Ripple Rejection	RR	$f = 120\text{Hz}$, $I_O=300\text{mA}$, $V_I=22 \text{ to } 32\text{V}$ $T_J = +25^\circ\text{C}$	-	70	-	dB
Dropout Voltage	V_D	$T_J = +25^\circ\text{C}$, $I_O=500\text{mA}$	-	2	-	V
Short Circuit Current	I_{SC}	$T_J = +25^\circ\text{C}$, $V_I=35\text{V}$	-	300	-	mA
Peak Current	I_{PK}	$T_J = +25^\circ\text{C}$	-	700	-	mA

Note:

1. Load and line regulation are specified at constant, junction temperature. Change in V_O due to heating effects must be taken into account separately. Pulse testing with low duty is used.

Electrical Characteristics (KA78M24) (Continued)(Refer to the test circuits, $0 \leq T_J \leq +125^\circ\text{C}$, $I_O=350\text{mA}$, $V_I=33\text{V}$, unless otherwise specified, $C_I=0.33\mu\text{F}$, $C_O=0.1\mu\text{F}$)

Parameter	Symbol	Conditions	Min.	Typ.	Max.	Unit
Output Voltage	V_O	$T_J = +25^\circ\text{C}$	23	24	25	V
		$I_O = 5$ to 350mA $V_I = 27$ to 38V	22.8	24	25.2	
Line Regulation	ΔV_O	$I_O = 200\text{mA}$ $T_J = +25^\circ\text{C}$	-	-	100	mV
		$V_I = 27$ to 38V $V_I = 28$ to 38V	-	-	50	
Load Regulation	ΔV_O	$I_O = 5\text{mA}$ to 0.5A , $T_J = +25^\circ\text{C}$	-	-	480	mV
		$I_O = 5\text{mA}$ to 200mA , $T_J = +25^\circ\text{C}$	-	-	240	
Quiescent Current	I_Q	$T_J = +25^\circ\text{C}$	-	4.2	6	mA
Quiescent Current Change	ΔI_Q	$I_O = 5\text{mA}$ to 350mA	-	-	0.5	mA
		$I_O = 200\text{mA}$ $V_I = 27$ to 38V	-	-	0.8	
Output Voltage Drift	$\Delta V/\Delta T$	$I_O = 5\text{mA}$ $T_J = 0$ to $+125^\circ\text{C}$	-	-1.2	-	mV/ $^\circ\text{C}$
Output Noise Voltage	V_N	$f = 10\text{Hz}$ to 100kHz	-	170	-	μV
Ripple Rejection	RR	$f = 120\text{Hz}$, $I_O = 300\text{mA}$ $V_I = 28$ to 38V , $T_J = +25^\circ\text{C}$	-	70	-	dB
Dropout Voltage	V_D	$T_J = +25^\circ\text{C}$, $I_O = 500\text{mA}$	-	2	-	V
Short Circuit Current	I_{SC}	$T_J = +25^\circ\text{C}$, $V_I = 35\text{V}$	-	300	-	mA
Peak Current	I_{PK}	$T_J = +25^\circ\text{C}$	-	700	-	mA

Note:

1. Load and line regulation are specified at constant, junction temperature. Change in V_O due to heating effects must be taken into account separately. Pulse testing with low duty is used.

Typical Applications

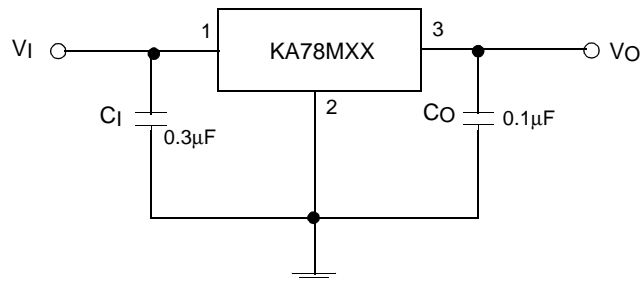

Figure 1. Fixed Output Regulator

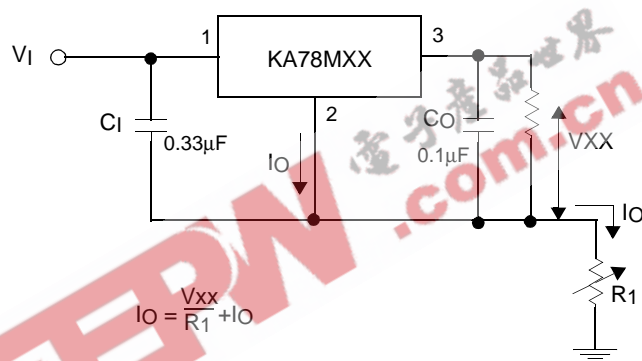

Figure 2. Constant Current Regulator

Notes:

1. To specify an output voltage, substitute voltage value for "XX"
2. Although no output capacitor is needed for stability, it does improve transient response.
3. Required if regulator is located an appreciable distance from power Supply filter

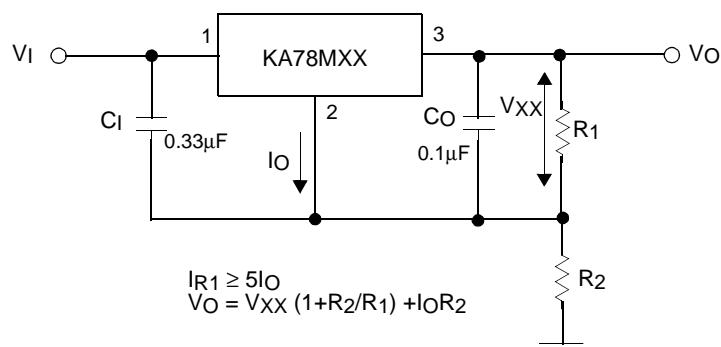

Figure 3. Circuit for Increasing Output Voltage

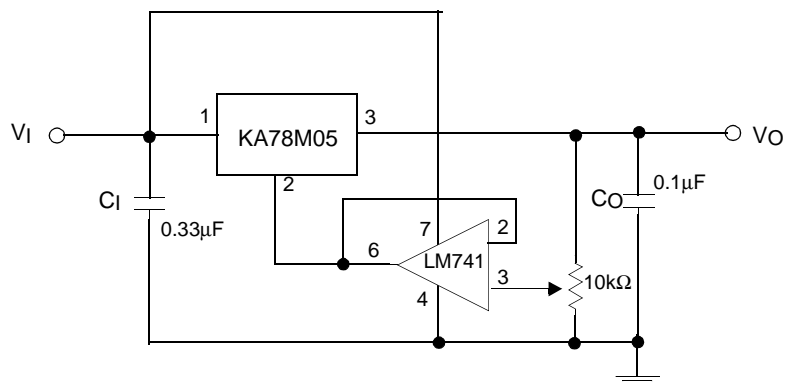

Figure 4. Adjustable Output Regulator (7 to 30V)

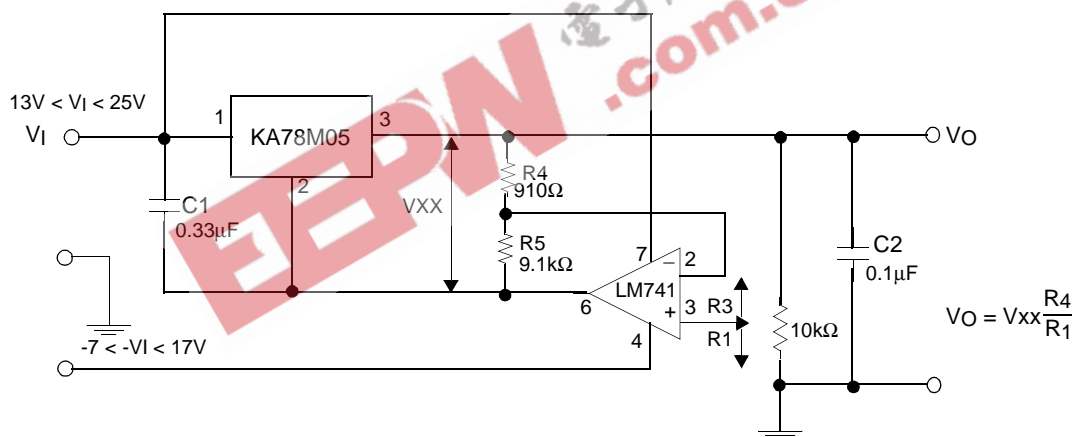

Figure 5. 0.5 to 10V Regulator

Mechanical Dimensions

Package

Dimensions in millimeters

TO-220

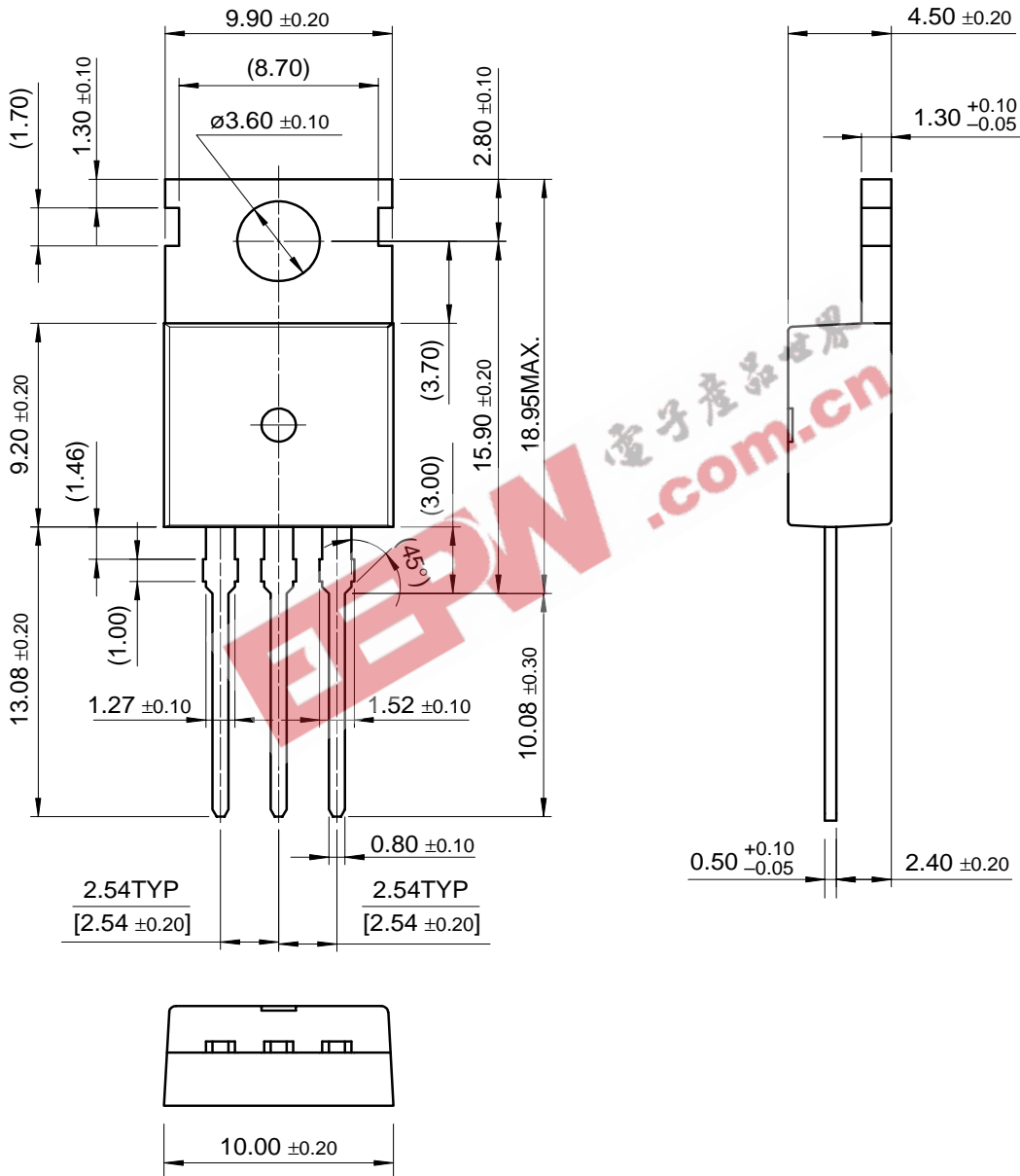

Mechanical Dimensions (Continued)

Package

Dimensions in millimeters

D-PAK

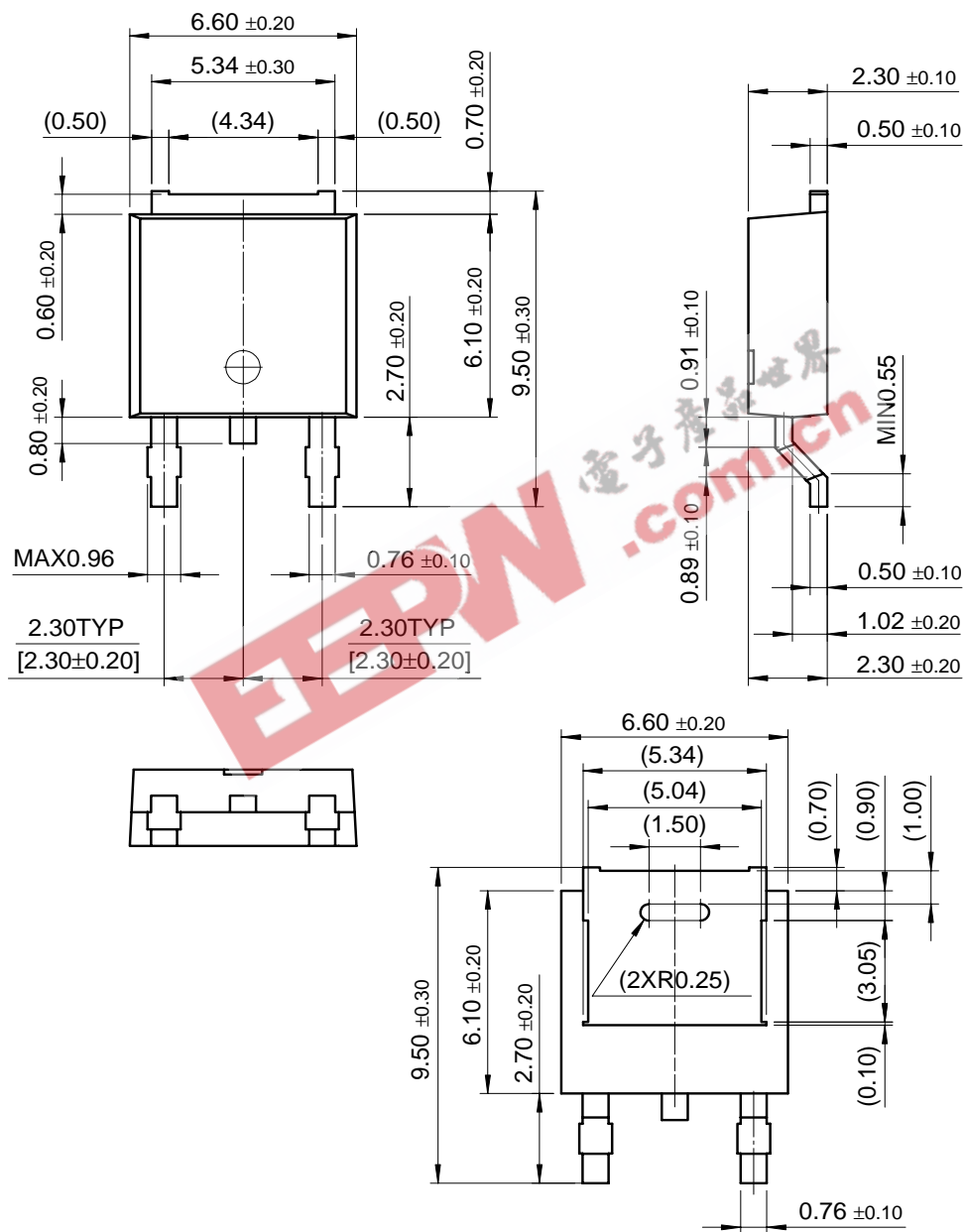

Ordering Information

Product Number	Package	Operating Temperature
KA78M05	TO-220	0 ~ +125°C
KA78M06		
KA78M08		
KA78M12		
KA78M15		
KA78M18		
KA78M24		
KA78M05R	D-PAK	
KA78M06R		
KA78M08R		
KA78M12R		

EEPW 电子产品世界
.com.cn



DISCLAIMER

FAIRCHILD SEMICONDUCTOR RESERVES THE RIGHT TO MAKE CHANGES WITHOUT FURTHER NOTICE TO ANY PRODUCTS HEREIN TO IMPROVE RELIABILITY, FUNCTION OR DESIGN. FAIRCHILD DOES NOT ASSUME ANY LIABILITY ARISING OUT OF THE APPLICATION OR USE OF ANY PRODUCT OR CIRCUIT DESCRIBED HEREIN; NEITHER DOES IT CONVEY ANY LICENSE UNDER ITS PATENT RIGHTS, NOR THE RIGHTS OF OTHERS.

LIFE SUPPORT POLICY

FAIRCHILD'S PRODUCTS ARE NOT AUTHORIZED FOR USE AS CRITICAL COMPONENTS IN LIFE SUPPORT DEVICES OR SYSTEMS WITHOUT THE EXPRESS WRITTEN APPROVAL OF THE PRESIDENT OF FAIRCHILD SEMICONDUCTOR CORPORATION. As used herein:

1. Life support devices or systems are devices or systems which, (a) are intended for surgical implant into the body, or (b) support or sustain life, and (c) whose failure to perform when properly used in accordance with instructions for use provided in the labeling, can be reasonably expected to result in a significant injury of the user.
2. A critical component in any component of a life support device or system whose failure to perform can be reasonably expected to cause the failure of the life support device or system, or to affect its safety or effectiveness.