

K1603TE Series

14 pin DIP, 5.0 Volt, CMOS/TTL, VCXO



Ordering Information

			00.0000
	K1603TE	-R	MHz
Product Series	_____		
RoHS Compliance	_____		
Blank:	non-RoHS compliant part		
-R:	RoHS compliant part		
Frequency (customer specified)	_____		

- Former **Champion** TECHNOLOGIES, INC. Product
- Clocking "Sync" to NTSC Video Standards, Reference Signal, Signal Tracking
- Stratium 3 Compliant

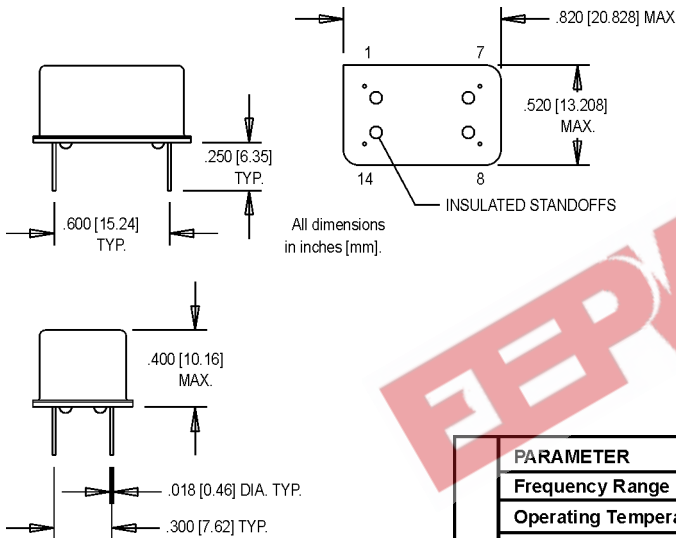

Pin Connections

PIN	FUNCTION
1	Tristate
7	Ground/Case Gnd
8	Output
14	+Vdd

PARAMETER	Symbol	Min.	Typ.	Max.	Units	Condition/Notes
Frequency Range	F	2		30	MHz	
Operating Temperature	T _A	-40		+85	°C	
Storage Temperature	T _s	-40		+85	°C	
Frequency Stability	ΔF/F			±4.6	ppm	
Aging (10 Year)		-2		+2	ppm	
Input Voltage	V _{dd}	4.75	5.0	5.25	V	
Input Current	I _{dd}			20	mA	
Output Type						HCMOS/TTL
Load		5 TTL or 15 pF HCMOS				See Note 1
Symmetry (Duty Cycle)						See Note 2
<14 MHz		45		55	%	
≥14 MHz		40		60	%	
Logic "1" Level	V _{oh}	4.5			V	
Logic "0" Level	V _{ol}			0.5	V	
Rise Time	T _r		3.5	9.0	ns	
Fall Time	T _f		2.0	8.0	ns	
Tristate Function		Input Logic "1" or N/C: output active Input Logic "0": output disables to high-Z				
Start up Time				10	ms	
Phase Noise (Typical)						
@ 20 MHz	-80	100 Hz -108	1 kHz -125	10 kHz -132	100 kHz -155	Offset from carrier dBc/Hz

1. TTL load - see load circuit diagram #1. HCMOS load - see load circuit diagram #2.
2. Symmetry is measured at 1.4 V with TTL load, and at 50% V_{dd} with HCMOS load.

MtronPTI reserves the right to make changes to the product(s) and service(s) described herein without notice. No liability is assumed as a result of their use or application.

Please see www.mtronpti.com for our complete offering and detailed datasheets. Contact us for your application specific requirements: MtronPTI 1-800-762-8800.

MtronPTI Lead Free Solder Profile

