

**HIGH EFFICIENCY
GLASS PASSIVATED RECTIFIER**

VOLTAGE RANGE 50 to 1000 Volts CURRENT 3.0 Ampere

FEATURES

- * Glass passivated junction
- * Low power loss, high efficiency
- * Low leakage
- * Low forward voltage drop
- * High current capability
- * High speed switching
- * High reliability
- * High current surge

MECHANICAL DATA

- * Case: Molded plastic
- * Epoxy: Device has UL flammability classification 94V-O
- * Lead: MIL-STD-202E method 208C guaranteed
- * Mounting position: Any
- * Weight: 1.20 grams

MAXIMUM RATINGS AND ELECTRICAL CHARACTERISTICS

Ratings at 25 °C ambient temperature unless otherwise specified.
Single phase, half wave, 60 Hz, resistive or inductive load.
For capacitive load, derate current by 20%.

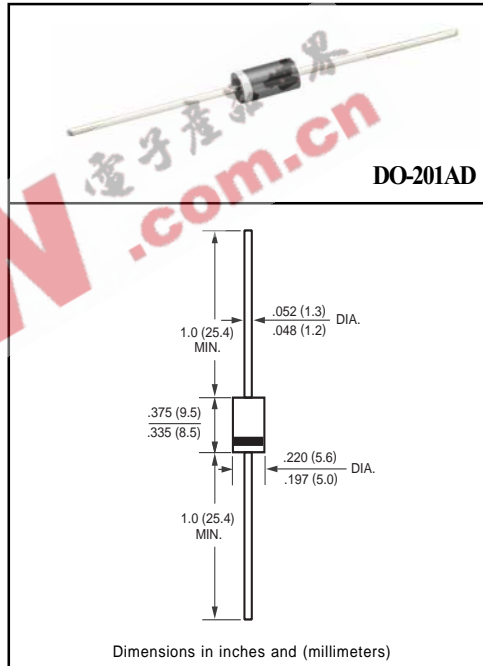

MAXIMUM RATINGS (At TA = 25°C unless otherwise noted)

RATINGS	SYMBOL	HER301G	HER302G	HER303G	HER304G	HER305G	HER305PG	HER306G	HER307G	HER308G	UNITS
Maximum Recurrent Peak Reverse Voltage	V _{RRM}	50	100	200	300	400	400	600	800	1000	Volts
Maximum RMS Voltage	V _{RMS}	35	70	140	210	280	280	420	560	700	Volts
Maximum DC Blocking Voltage	V _{DC}	50	100	200	300	400	400	600	800	1000	Volts
Maximum Average Forward Rectified Current at TA= 50°C	I _O	3.0									Amps
Peak Forward Surge Current 8.3 ms single half sine-wave superimposed on rated load (JEDEC method)	I _{FSM}	200				150				Amps	
Typical Junction Capacitance (Note 2)	C _J	70				50				pF	
Operating and Storage Temperature Range	T _J , T _{STG}	-65 to + 175									°C

ELECTRICAL CHARACTERISTICS (At TA = 25°C unless otherwise noted)

CHARACTERISTICS	SYMBOL	HER301G	HER302G	HER303G	HER304G	HER305G	HER305PG	HER306G	HER307G	HER308G	UNITS	
Maximum Instantaneous Forward Voltage at 3.0A DC	V _F	1.0		1.3		1.0		1.70			Volts	
Maximum DC Reverse Current at Rated DC Blocking Voltage TA = 25°C	I _R	10										uAmps
Maximum Full Load Reverse Current Average, Full Cycle .375" (9.5mm) lead length at TL = 55°C		150										uAmps
Maximum Reverse Recovery Time (Note 1)	t _{rr}	50				75				nSec		

NOTES : 1. Test Conditions: I_F = 0.5A, I_R = -1.0A, I_{RR} = -0.25A

2. Measured at 1 MHz and applied reverse voltage of 4.0 volts

RATING AND CHARACTERISTIC CURVES (HER301G THRU HER308G)

FIG. 1 - TEST CIRCUIT DIAGRAM AND REVERSE RECOVERY TIME CHARACTERISTIC

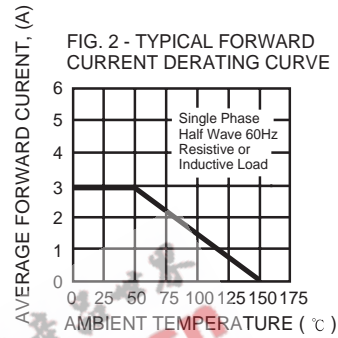
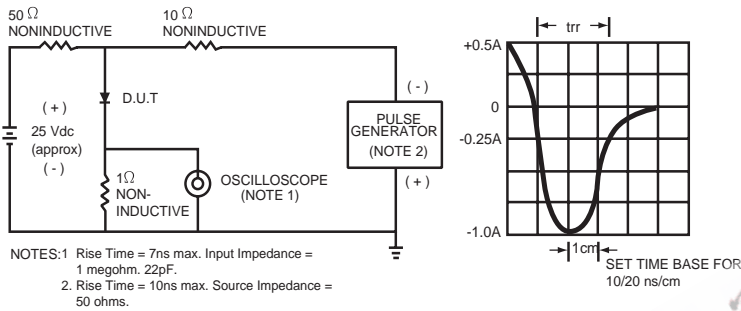

FIG. 3 - TYPICAL REVERSE CHARACTERISTICS

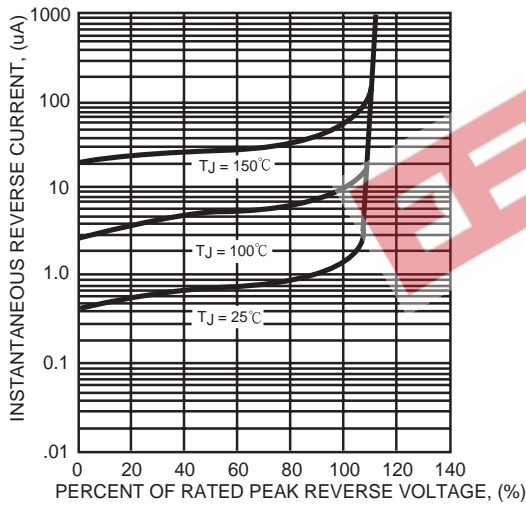

FIG. 4 - TYPICAL INSTANTANEOUS FORWARD CHARACTERISTICS

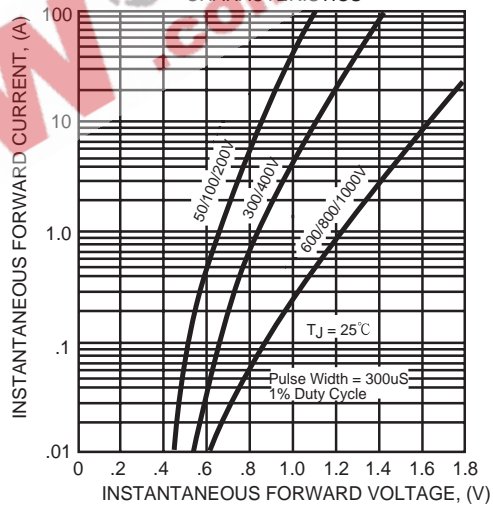

FIG. 5 - MAXIMUM NON-REPETITIVE FORWARD SURGE CURRENT

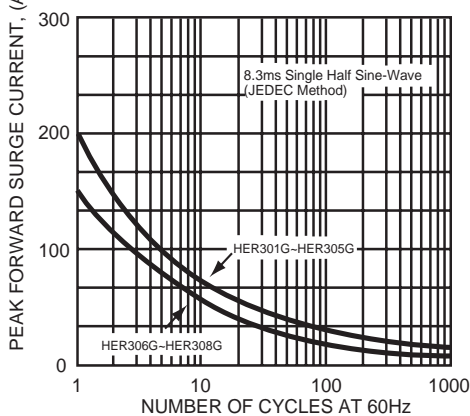

FIG. 6 - TYPICAL JUNCTION CAPACITANCE

