

BA157 - BA159

1.0 AMP. Fast Recovery Rectifiers

DO-41



Features

- ✧ High efficiency, Low VF
- ✧ High current capability
- ✧ High reliability
- ✧ High surge current capability
- ✧ Low power loss.

Mechanical Data

- ✧ Cases: DO-41 Molded plastic
- ✧ Epoxy: UL 94V-0 rate flame retardant
- ✧ Lead: Pure tin plated, Lead free., solderable per MIL-STD-202, Method 208 guaranteed
- ✧ Polarity: Color band denotes cathode end
- ✧ High temperature soldering guaranteed: 260°C/10 seconds/.375", (9.5mm) lead lengths at 5 lbs., (2.3kg) tension
- ✧ Weight: 0.34 gram

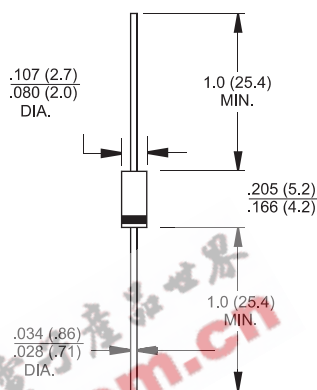

Dimensions in inches and (millimeters)

Maximum Ratings and Electrical Characteristics

Rating at 25 °C ambient temperature unless otherwise specified.

Single phase, half wave, 60 Hz, resistive or inductive load.

For capacitive load, derate current by 20%

Type Number	Symbol	BA157	BA158	BA159	Units
Maximum Recurrent Peak Reverse Voltage	V_{RRM}	400	600	1000	V
Maximum RMS Voltage	V_{RMS}	280	420	700	V
Maximum DC Blocking Voltage	V_{DC}	400	600	1000	V
Maximum Average Forward Rectified Current .375"(9.5mm) Lead Length @ $T_A = 45^\circ C$	$I_{(AV)}$	1.0			A
Peak Forward Surge Current, 8.3 ms Single Half Sine-wave Superimposed on Rated Load (JEDEC method)	I_{FSM}	30			A
Maximum Instantaneous Forward Voltage @ 1.0A	V_F	1.2			V
Maximum DC Reverse Current @ $T_A=25^\circ C$ at Rated DC Blocking Voltage @ $T_A=125^\circ C$	I_R	5.0 150			μA μA
Maximum Reverse Recovery Time (Note 1)	T_{rr}	150		250	nS
Typical Junction Capacitance (Note 2)	C_j	10			pF
Typical Thermal Resistance	$R_{\theta JA}$	65			$^\circ C/W$
Operating Temperature Range	T_J	-65 to +150			$^\circ C$
Storage Temperature Range	T_{STG}	-65 to +150			$^\circ C$

- Notes:
1. Reverse Recovery Test Conditions: $I_F=0.5A$, $I_R=1.0A$, $I_{RR}=0.25A$
 2. Measured at 1 MHz and Applied Reverse Voltage of 4.0 Volts D.C.
 3. Mount on Cu-Pad Size 5mm x 5mm on P.C.B.

RATINGS AND CHARACTERISTIC CURVES (BA157 THRU BA159)

FIG.1- MAXIMUM FORWARD CURRENT DERATING CURVE

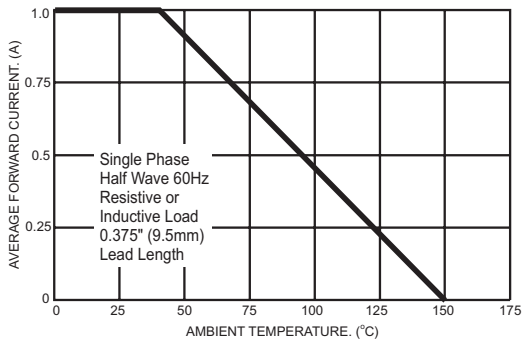

FIG.2- TYPICAL REVERSE CHARACTERISTICS PER LEG

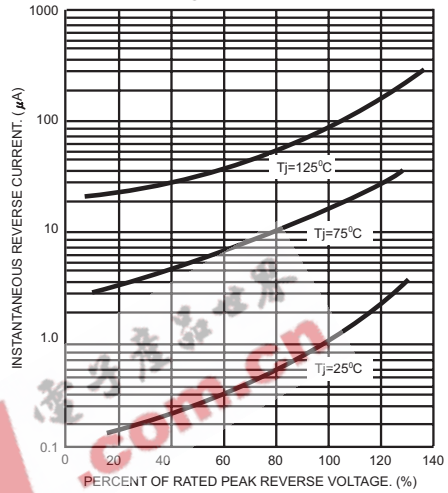

FIG.3- MAXIMUM NON-REPETITIVE FORWARD SURGE CURRENT

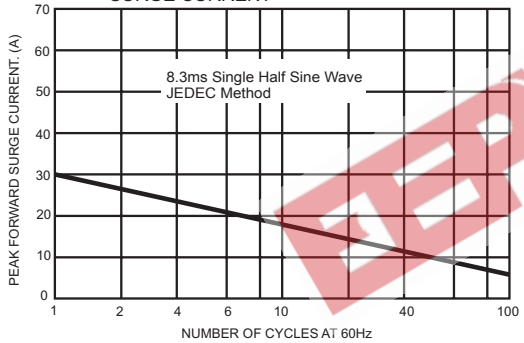

FIG.5- TYPICAL FORWARD CHARACTERISTICS

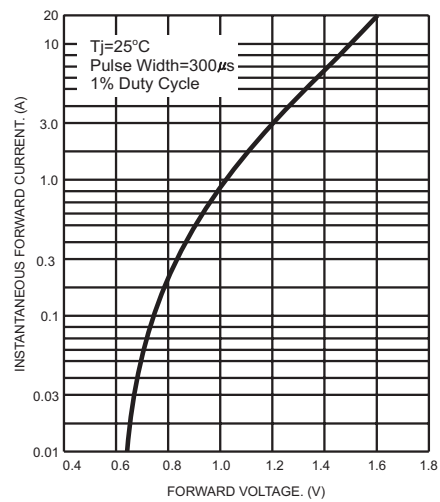

FIG.4- TYPICAL JUNCTION CAPACITANCE

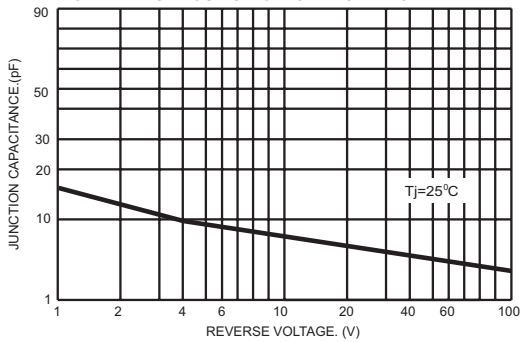

FIG.6- REVERSE RECOVERY TIME CHARACTERISTIC AND TEST CIRCUIT DIAGRAM

