



KBP201G - KBP207G

Single Phase 2.0 AMPS.
Glass Passivated Bridge Rectifiers

KBP

Features

- ✧ UL Recognized File # E-96005
- ✧ Glass passivated junction
- ✧ Ideal for printed circuit board
- ✧ Reliable low cost construction technique results in inexpensive product
- ✧ High temperature soldering guaranteed: 260°C / 10 seconds at 5 lbs. (2.3 Kg) tension
- ✧ Small size, simple installation
Leads solderable per MIL-STD-202, Method 208

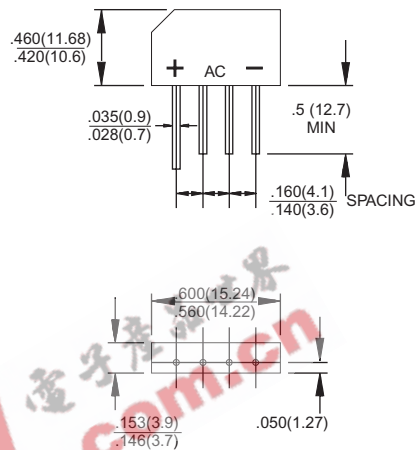

Dimensions in inches and (millimeters)

Maximum Ratings and Electrical Characteristics

Rating at 25°C ambient temperature unless otherwise specified.

Single phase, half wave, 60 Hz, resistive or inductive load.

For capacitive load, derate current by 20%

Type Number	Symbol	KBP 201G	KBP 202G	KBP 203G	KBP 204G	KBP 205G	KBP 206G	KBP 207G	Units
Maximum Recurrent Peak Reverse Voltage	V_{RRM}	50	100	200	400	600	800	1000	V
Maximum RMS Voltage	V_{RMS}	35	70	140	280	420	560	700	V
Maximum DC Blocking Voltage	V_{DC}	50	100	200	400	600	800	1000	V
Maximum Average Forward Rectified Current @ $T_A = 50^\circ\text{C}$	$I_{(AV)}$	2.0							A
Peak Forward Surge Current, 8.3 ms Single Half Sine-wave Superimposed on Rated Load (JEDEC method)	I_{FSM}	60							A
Rating for Fusing ($t < 8.35\text{ms}$)	I^2t	15							A^2sec
Maximum Instantaneous Forward Voltage @ 3.14A	V_F	1.2							V
Maximum DC Reverse Current @ $T_A = 25^\circ\text{C}$ at Rated DC Blocking Voltage @ $T_A = 125^\circ\text{C}$	I_R	10 500							μA μA
Typical thermal resistance (Note)	$R_{\theta JA}$ $R_{\theta JL}$	25 8							$^\circ\text{C}/\text{W}$
Operating Temperature Range	T_J	-55 to +150							$^\circ\text{C}$
Storage Temperature Range	T_{STG}	-55 to +150							$^\circ\text{C}$

Note: Thermal Resistance from Junction to Ambient and from Junction to Lead Mounted on P.C.B. With 0.4" x 0.4" (10 x 10mm) Copper Pads.

RATINGS AND CHARACTERISTIC CURVES (KBP201G THRU KBP207G)

FIG.1- MAXIMUM FORWARD CURRENT DERATING CURVE

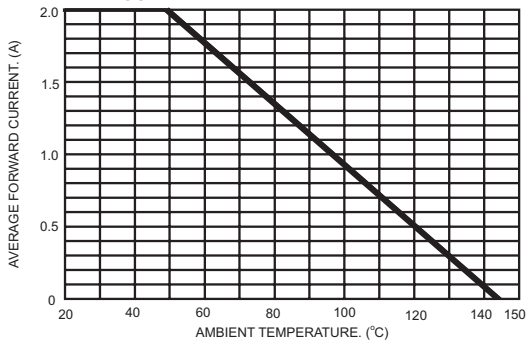

FIG.2- TYPICAL REVERSE CHARACTERISTICS PER BRIDGE ELEMENT

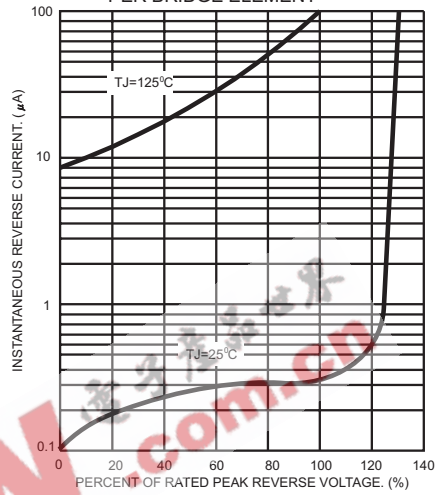

FIG.3- MAXIMUM NON-REPETITIVE FORWARD SURGE CURRENT PER BRIDGE ELEMENT

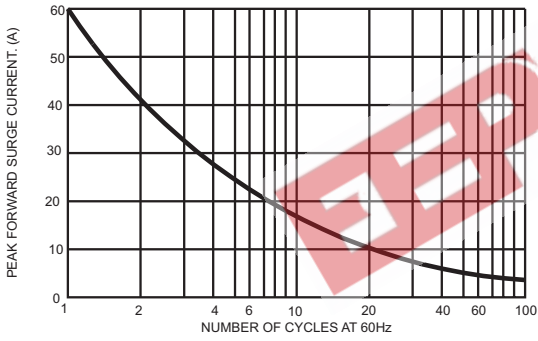

FIG.4- TYPICAL JUNCTION CAPACITANCE

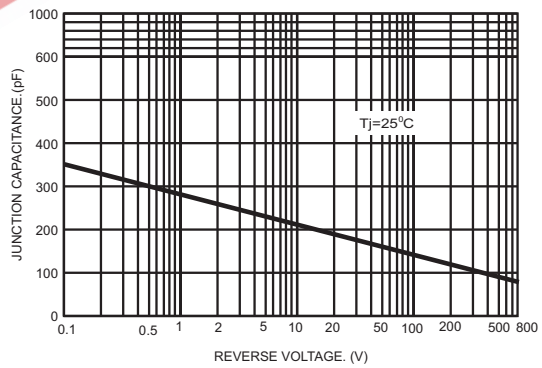

FIG.5- TYPICAL FORWARD CHARACTERISTICS PER BRIDGE ELEMENT

