



KBP201 THRU KBP207

Single Phase 2.0 AMPS. Silicon Bridge Rectifiers



Voltage Range
50 to 1000 Volts
Current
2.0 Amperes

Features

- ◇ UL Recognized File # E-96005
- ◇ Glass passivated junction
- ◇ Ideal for printed circuit board
- ◇ Reliable low cost construction technique results in inexpensive product
- ◇ High temperature soldering guaranteed: 260 °C / 10 seconds at 5 lbs. (2.3 Kg) tension
- ◇ Small size, simple installation
Leads solderable per MIL-STD-202, Method 208

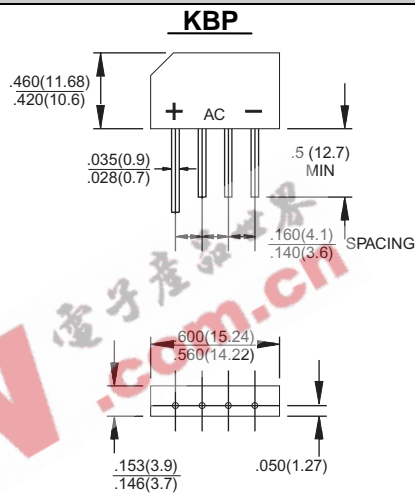

Dimensions in inches and (millimeters)

Maximum Ratings and Electrical Characteristics

Rating at 25°C ambient temperature unless otherwise specified.

Single phase, half wave, 60 Hz, resistive or inductive load.

For capacitive load, derate current by 20%

Type Number	Symbol	KBP 201	KBP 202	KBP 203	KBP 204	KBP 205	KBP 206	KBP 207	Units
Maximum Recurrent Peak Reverse Voltage	V_{RRM}	50	100	200	400	600	800	1000	V
Maximum RMS Voltage	V_{RMS}	35	70	140	280	420	560	700	V
Maximum DC Blocking Voltage	V_{DC}	50	100	200	400	600	800	1000	V
Maximum Average Forward Rectified Current @ $T_A = 50^\circ\text{C}$	$I_{(AV)}$	2.0							A
Peak Forward Surge Current, 8.3 ms Single Half Sine-wave Superimposed on Rated Load (JEDEC method)	I_{FSM}	60							A
Maximum Instantaneous Forward Voltage @ 2.0A	V_F	1.2							V
Maximum DC Reverse Current @ $T_A=25^\circ\text{C}$ at Rated DC Blocking Voltage @ $T_A=125^\circ\text{C}$	I_R	10 500							uA uA
Typical Thermal Resistance (Note)	$R_{\theta JA}$ $R_{\theta JL}$	25 8							$^\circ\text{C/W}$
Operating Temperature Range	T_J	-55 to +125							$^\circ\text{C}$
Storage Temperature Range	T_{STG}	-55 to +150							$^\circ\text{C}$

Note: Thermal Resistance from Junction to Ambient and from Junction to Lead Mounted on P.C.B. With 0.47 x 0.47" (12 x 12mm) Copper Pads.



RATINGS AND CHARACTERISTIC CURVES (KBP201 THRU KBP207)

FIG.1- MAXIMUM NON-REPETITIVE FORWARD SURGE CURRENT PER BRIDGE ELEMENT

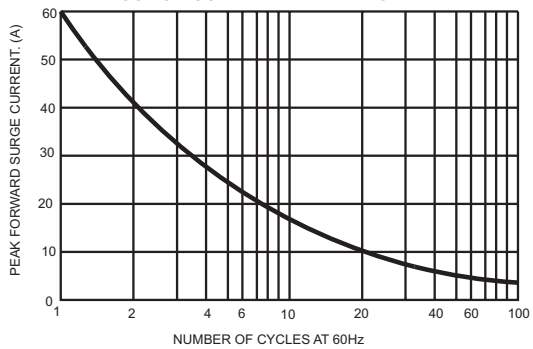

FIG.2- MAXIMUM FORWARD CURRENT DERATING CURVE

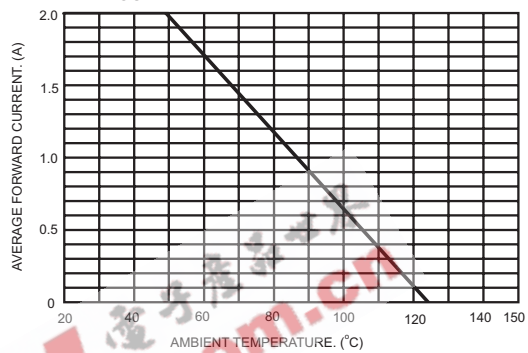

FIG.3- TYPICAL INSTANTANEOUS FORWARD CHARACTERISTICS PER BRIDGE ELEMENT

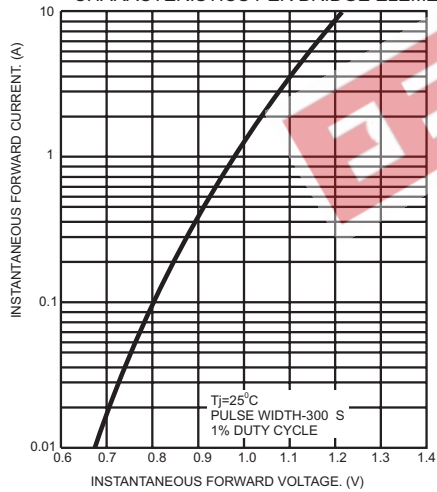

FIG.4- TYPICAL REVERSE CHARACTERISTICS PER BRIDGE ELEMENT

