

M/A-COM 0.5 W, 2.4 GHz Power Amplifier

V 1.4

AM52-0024

Features

- Ideal for 802.11b ISM Applications
- Single Positive Supply
- Output Power 27.5 dBm
- 57% Typical Power Added Efficiency
- Downset MSOP-8 Package

Description

M/A-COM's AM52-0024 is a 0.5 W, 2.4 GHz GaAs MMIC, power amplifier in a low-cost MSOP-8 package. It employs some external matching to obtain optimum input return loss and output power performance. The AM52-0024 may be operated with supply voltages of +3.3 V to +5.5 V.

The AM52-0024 may be used in a wide variety of applications including WLAN, WDECT, and Bluetooth.

The AM52-0024 is fabricated using M/A-COM's Self-Aligned MSAG MESFET process to realize high power efficiency, single supply voltage, and small size. The process features full passivation for increased performance and reliability.

Functional Schematic

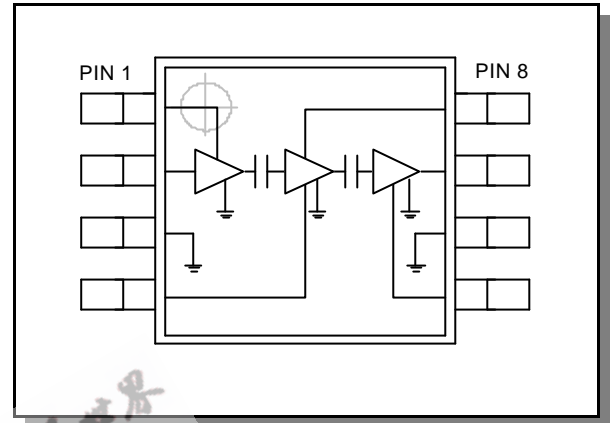

Ordering Information

Part Number	Package
AM52-0024TR	7 inch, 1000 Piece Reel
AM52-0024TR-3000	13 inch, 3000 Piece Reel
AM52-0024SMB	Sample Test Board

Electrical Specifications ^{1,2}: $T_s = +37^\circ\text{C}$ (temperature measured at the soldering point of the downset paddle)

Characteristic	Min	Typ	Max	Unit	Test Conditions
Frequency	2.4		2.5	GHz	
Output Power	25.5	27.5		dBm	F = 2450 MHz, $P_{IN} = -2$ dBm
Power Added Efficiency		57		%	F = 2450 MHz, $P_{IN} = -2$ dBm
Current Under Drive		300		mA	F = 2450 MHz, $P_{IN} = -2$ dBm
Current Under Linear Operation	130	230	300	mA	F = 2450 MHz, $P_{OUT} = +20$ dBm
Small Signal Gain		29.0		dB	F = 2450 MHz, $P_{OUT} = +20$ dBm
Harmonics		-40		dBc	F = 2450 MHz, $P_{IN} = -2$ dBm
Input VSWR		1.4:1	2.0:1	-	F = 2450 MHz, $P_{IN} = -2$ dBm
Off Isolation		40		dB	F = 2450 MHz, $V_{DD} = 0$ V
Thermal Resistance, junction to package bottom		25		$^\circ\text{C}/\text{W}$	F = 2450 MHz, $P_{IN} = -2$ dBm
Third Order Intercept Point		40		dBm	F1 = 2450 MHz, $P_{IN} = -20$ dBm F2 = 2451 MHz, $P_{IN} = -20$ dBm
Load Mismatch	No Degradation in Power Output			-	$V_{DD} = 5.5$ V, VSWR = 8:1, $P_{IN} = 0$ dBm
Stability	All non-harmonically related outputs more than 60 dB below desired signal			-	$P_{IN} = -2$ to +2 dBm, $V_{DD} = 0$ to 5.5 V, Load VSWR = 6:1, all phases

1. $V_{DD} = +3.3$ Volts, $P_{IN} = -2$ dBm, Frequency = 2450 MHz, and Duty Cycle = 100% unless otherwise specified.
2. All Measurements taken in a 50 Ω system unless otherwise specified.

MSOP-8EP Plastic Package

Dimensions	Measurement (mm)		Measurement (inches)	
	Min	Max	Min	Max
A	0.80	1.10	0.0315	0.0433
A1	0.026	0.076	0.0010	0.0030
A2	0.75	0.95	0.0295	0.0374
b	0.25	0.40	0.0098	0.0157
D	2.90	3.10	0.1142	0.01220
D1	1.85 ref.	1.85 ref.	0.073 ref.	0.073 ref.
E	4.90 basic	4.90 basic	0.1929 basic	0.1929 basic
E1	2.90	3.10	0.1142	0.1220
E2	1.73 ref.	1.73 ref.	0.068 ref.	0.068 ref.
e	0.65 basic	0.65 basic	0.0256 basic	0.0256 basic
L	0.40	1.70	0.0157	0.0276
Theta (θ)	0°	6°	0°	60°

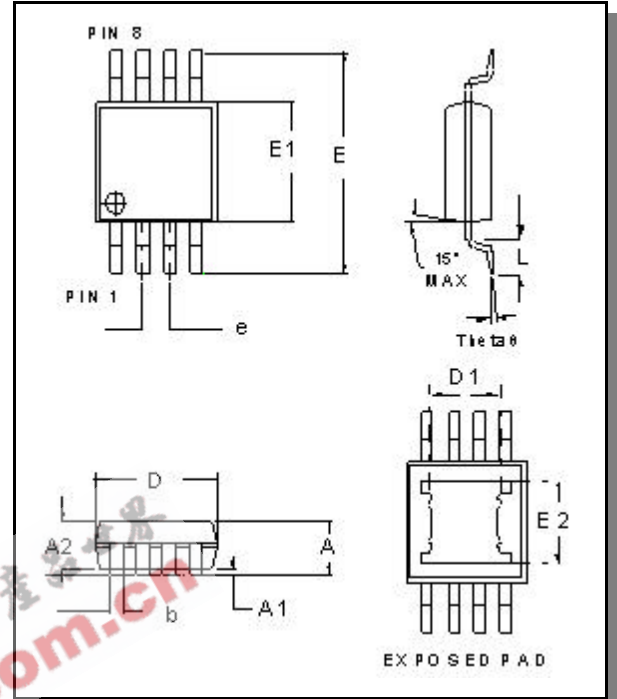

Pin Configuration ³

Pin	Function	Description
1	V _{D1}	Drain Voltage for First Stage
2	RF _{IN} /V _{G1}	RF input and Gate Voltage for First Stage
3	GND	Ground
4	V _{G2}	Gate Bias for Second Stage
5	V _{G3}	Gate Bias for Third Stage
6	GND	Ground
7	RF _{OUT} /V _{D3}	RF Output and Drain Voltage for Third Stage
8	V _{D2}	Drain Voltage for Second Stage

3. Package bottom is electrical and thermal ground

Note: All dimensions per JEDEC MO-187 Var. AA (issue B) except for D1, E2, and A1. See JEDEC or contact M/A-COM for additional dimensional and tolerance information.

Absolute Maximum Ratings ⁴

Rating	Symbol	Value	Unit
DC Supply Voltage	V _{DD}	5.5	V
RF Input Power	P _{IN}	10	mW
Junction Temperature	T _J	150	°C
Storage Temperature Range	T _{STG}	-40 to +150	°C
Operating Temperature	T _{OPER}	-40 to +100	°C

4. Exceeding these limits may cause permanent damage.

Specifications subject to change without notice.

- North America: Tel. (800) 366-2266
- Asia/Pacific: Tel.+81-44-844-8296, Fax +81-44-844-8298
- Europe: Tel. +44 (1344) 869 595, Fax+44 (1344) 300 020

Visit www.macom.com for additional data sheets and product information.

Application Information

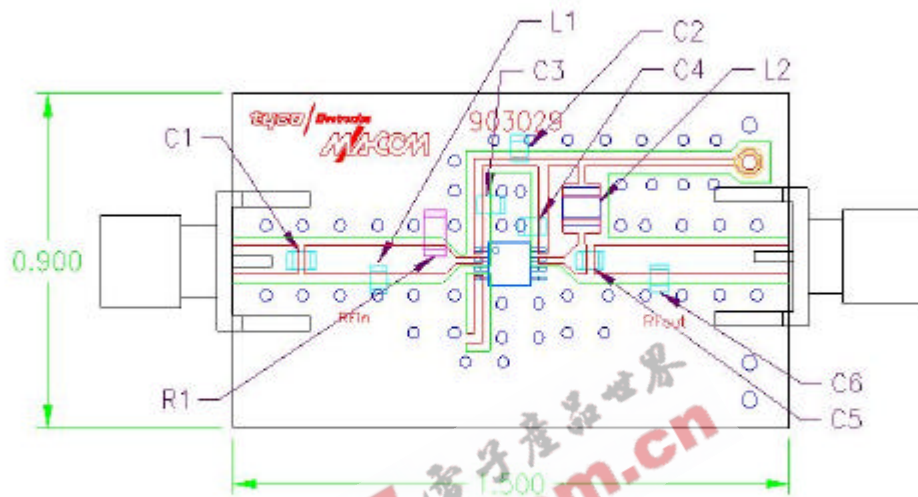

Specifications subject to change without notice.

- North America: Tel. (800) 366-2266
- Asia/Pacific: Tel.+81-44-844-8296, Fax +81-44-844-8298
- Europe: Tel. +44 (1344) 869 595, Fax+44 (1344) 300 020

Visit www.macom.com for additional data sheets and product information.

Evaluation Board Schematic

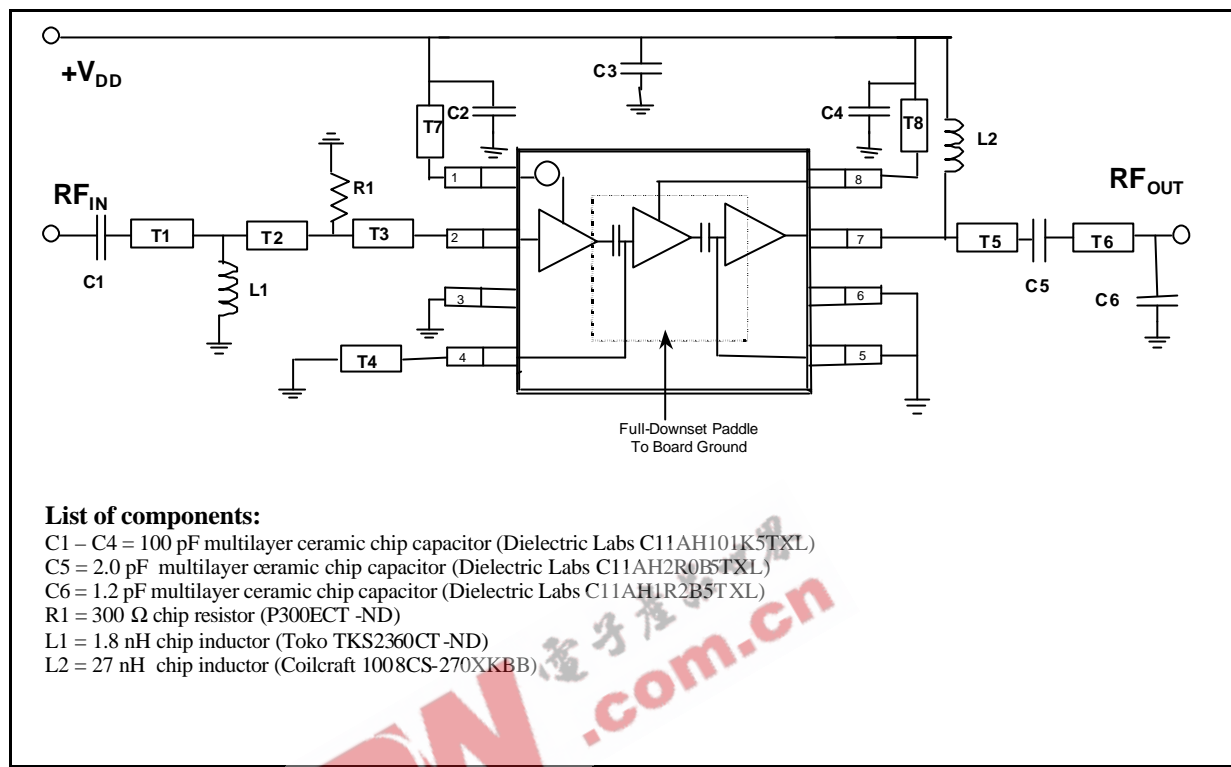

Transmission Line	Length	Width
T1	0.15 inches	0.077 inches
T2	0.21 inches	0.077 inches
T3	0.11 inches	0.077 inches
T4	0.16 inches	0.026 inches
T5	0.13 inches	0.077 inches
T6	0.16 inches	0.077 inches
T7	0.13 inches	0.026 inches
T8	0.07 inches	0.026 inches

* Lengths and widths are given for a 0.060 inch thick FR-4 board (distance between RF and ground planes) with dielectric constant of approximately 4.3.

Specifications subject to change without notice.

- North America: Tel. (800) 366-2266
- Asia/Pacific: Tel.+81-44-844-8296, Fax +81-44-844-8298
- Europe: Tel. +44 (1344) 869 595, Fax+44 (1344) 300 020

Visit www.macom.com for additional data sheets and product information.

Typical Performance Curves

Gain vs. Frequency, over Temperature

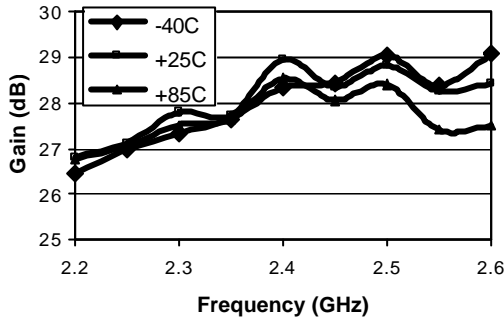

Input Return Loss vs. Frequency, over Temperature

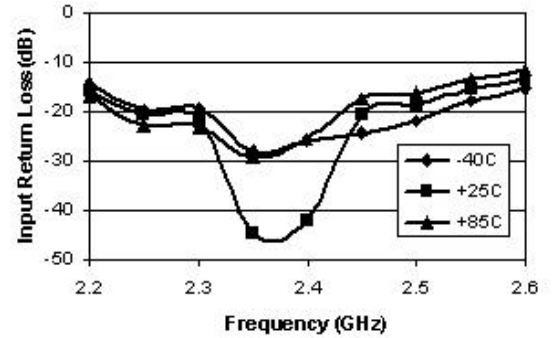

Drain Current vs. Frequency, over Temperature

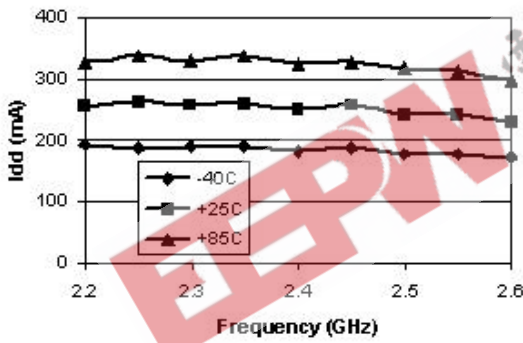

Gain and Drain Current vs. Voltage, $T_s = +37\text{ }^\circ\text{C}$

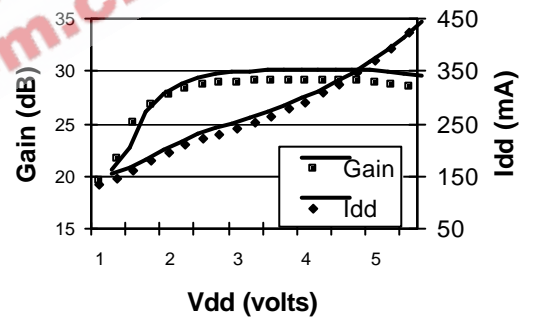

Output Power and Drain Current vs. Input Power, $T_s = +37\text{ }^\circ\text{C}$

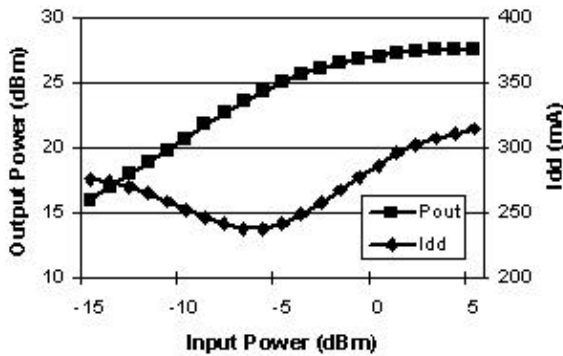

Specifications subject to change without notice.

- North America: Tel. (800) 366-2266
- Asia/Pacific: Tel.+81-44-844-8296, Fax +81-44-844-8298
- Europe: Tel. +44 (1344) 869 595, Fax+44 (1344) 300 020

Visit www.macom.com for additional data sheets and product information.

Designing With the AM52-0024

The AM52-0024 is built using a near-enhancement mode FET that operates from a single supply voltage. A negative voltage is not required because the FET is designed to operate with a +0V DC gate bias.

To duplicate AM52-0024 data sheet performance, the circuit board must present the same impedances realized on this evaluation board. The table below has impedance measurements looking into the traces on the evaluation board,

Frequency GHz	V _{DD1} Pin 1		RF _{IN} /V _{GG1} Pin 2		V _{GG2} Pin 4		RF _{OUT} /V _{DD3} Pin 7		V _{DD2} Pin 8	
	MAG	ANG	MAG	ANG	MAG	ANG	MAG	ANG	MAG	ANG
0.2	0.98890	168.89	0.98437	158.43	0.98990	157.75	0.96758	88.92	0.98740	170.03
0.3	0.88449	130.14	0.97810	148.00	0.98811	147.07	0.93440	52.01	0.87259	126.11
0.4	0.96296	162.21	0.96932	138.02	0.98733	136.83	0.89791	28.02	0.95647	168.46
0.5	0.98166	159.36	0.96033	128.52	0.98729	126.92	0.85525	8.85	0.97951	165.71
0.6	0.98669	150.11	0.95221	119.37	0.98779	117.53	0.80306	-8.42	0.98325	157.06
0.7	0.98659	142.94	0.94257	110.68	0.98796	108.67	0.75165	-23.19	0.98331	150.64
0.8	0.98701	136.46	0.93372	102.50	0.98912	100.34	0.70235	-36.51	0.98362	144.92
0.9	0.98696	130.40	0.92399	94.78	0.98928	92.48	0.65785	-49.03	0.98291	139.57
1.0	0.98757	124.64	0.91521	87.48	0.99004	85.10	0.61674	-61.22	0.98248	134.49
1.1	0.98793	119.13	0.90655	80.60	0.99099	78.16	0.58189	-73.60	0.98325	129.55
1.2	0.98766	113.79	0.89741	74.13	0.99165	71.67	0.55207	-86.36	0.98254	124.75
1.3	0.98685	108.52	0.88850	68.01	0.99162	65.55	0.52778	-99.76	0.98097	119.95
1.4	0.98253	103.08	0.87922	62.20	0.99228	59.78	0.51054	-113.87	0.97567	14.77
1.5	0.91016	98.26	0.87041	56.61	0.99283	54.27	0.50134	-128.62	0.88506	109.11
1.6	0.97895	96.95	0.85901	51.24	0.99372	49.02	0.50184	-143.72	0.96660	110.93
1.7	0.98693	91.94	0.84867	46.25	0.99362	44.08	0.51099	-159.03	0.97912	105.76
1.8	0.98885	87.51	0.83780	41.39	0.99411	39.33	0.52890	-174.06	0.98174	101.51
1.9	0.98968	83.39	0.82602	36.67	0.99457	34.73	0.55378	171.57	0.98247	97.56
2.0	0.99001	79.46	0.81268	32.09	0.99405	30.31	0.58373	158.06	0.98252	93.75
2.1	0.98939	75.68	0.79856	27.65	0.99409	26.02	0.61689	145.85	0.96646	89.86
2.2	0.9079	72.12	0.78264	23.35	0.99430	21.85	0.65283	133.76	0.98349	87.18
2.3	0.99100	68.61	0.76563	19.11	0.99427	17.75	0.68573	123.12	0.98395	83.71
2.4	0.99134	65.25	0.74652	14.96	0.99425	13.76	0.71788	113.31	0.98474	80.41
2.5	0.99146	61.98	0.72506	10.91	0.99399	9.82	0.74798	104.32	0.98447	77.23
2.6	0.99178	58.73	0.70186	6.91	0.99400	5.85	0.77528	95.95	0.98507	74.04
2.7	0.99134	55.49	0.67587	2.97	0.99331	1.90	0.79976	88.27	0.98381	70.83
2.8	0.98781	52.20	0.64683	-0.91	0.99282	-2.00	0.82079	81.13	0.98006	67.52
2.9	0.96980	48.90	0.61470	-4.81	0.99214	-5.98	0.83832	74.49	0.96403	63.91
3.0	0.95172	48.55	0.57400	-8.86	0.99108	-9.98	0.85400	68.30	0.90400	62.55
3.1	0.98242	46.16	0.52740	-11.19	0.98954	-13.99	0.86663	62.57	0.95087	63.65
3.2	0.99063	43.08	0.48956	-13.34	0.98827	-18.12	0.87801	57.07	0.97696	60.24
3.3	0.99392	40.27	0.44620	-15.29	0.98684	-22.42	0.88698	51.92	0.98397	57.19
3.4	0.99353	37.51	0.40182	-16.23	0.98579	-26.81	0.89353	46.93	0.98539	54.35
3.5	0.99183	34.87	0.35797	-15.65	0.98338	-31.29	0.89823	42.18	0.98374	51.69
3.6	0.98528	32.36	0.31683	-13.12	0.98114	-36.02	0.90042	37.52	0.97595	49.24
3.7	0.98115	30.74	0.28368	-7.89	0.97774	-40.95	0.89832	32.95	0.97468	47.68
3.8	0.99055	28.59	0.26456	-0.17	0.97527	-46.15	0.88711	28.34	0.98255	45.41
3.9	0.99468	26.15	0.26206	8.43	0.97149	-51.66	0.85217	23.98	0.98187	42.91
4.0	0.99541	23.85	0.27526	16.18	0.96801	-57.48	0.78439	25.69	0.97076	41.20

Specifications subject to change without notice.

- North America: Tel. (800) 366-2266
- Asia/Pacific: Tel.+81-44-844-8296, Fax +81-44-844-8298
- Europe: Tel. +44 (1344) 869 595, Fax+44 (1344) 300 020

Visit www.macom.com for additional data sheets and product information.