

### Features

- Diffused Junction
- Low Reverse Leakage Current
- Low Power Loss, High Efficiency
- Surge Overload Rating to 400A Peak
- Electrically Isolated Metal Case for Maximum Heat Dissipation
- High Case Dielectric Strength of 1500V<sub>RMS</sub>

### Mechanical Data

- Case : High Conductivity Metal
- Terminals : Plated Leads Solderable per MIL-STD-202, Method 208
- Polarity : Symbols Marked on Case
- Mounting : Through Hole for #10 Screw
- Mounting Torque : 8.0 Inch-pounds Maximum
- Weight : KBPC 31.6 grams (approx.)  
KBPC-W 28.5 grams (approx.)
- Mounting Position : Any
- Marking : Type Number

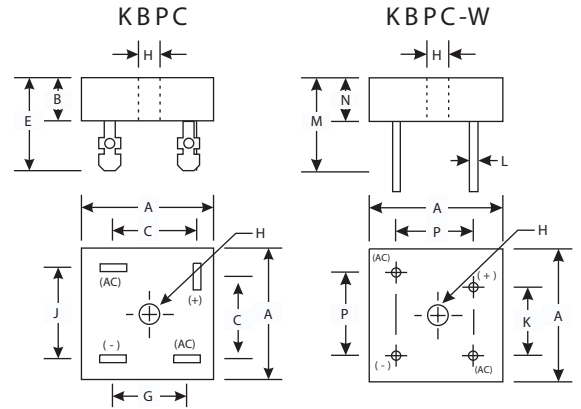

KBPC / KBPC-W					
Dim	Min	Max	Dim	Min	Max
A	28.40	28.70	J	17.10	19.10
B	10.97	11.23	K	10.40	12.40
C	15.50	17.60	L	0.97 $\phi$	1.07 $\phi$
E	22.86	25.40	M	30.50	—
G	13.30	15.30	N	10.97	11.23
H	Hole for #10 screw		P	17.10	19.10
	4.85 $\phi$	5.59 $\phi$			

All Dimensions in mm  
"W" Suffix Designates Wire Leads  
No Suffix Designates Fast-on Terminals

### Maximum Ratings And Electrical Characteristics

(Ratings at 25 °C ambient temperature unless otherwise specified, Single phase, half wave 60Hz, resistive or inductive load. For capacitive load, derate by 20%)

	Symbols	KBPC25 005/W	KBPC25 01/W	KBPC25 02/W	KBPC25 04/W	KBPC25 06/W	KBPC25 08/W	KBPC25 10/W	Units
Peak Repetitive Reverse voltage	V <sub>RMM</sub>								Volts
Working Peak Reverse voltage	V <sub>RWM</sub>	50	100	200	400	600	800	1000	Volts
DC Blocking voltage	V <sub>R</sub>								Volts
RMS Reverse voltage	V <sub>R(RMS)</sub>	35	70	140	280	420	560	700	Volts
Average Rectified Output Current @ T <sub>c</sub> =55 °C	I <sub>o</sub>	25							Amps
Non-Repetitive Peak Forward Surge Current, 8.3ms single half-sine-wave superimposed on rated load (JEDEC method)	I <sub>FSM</sub>	400							Amps
Forward voltage (per element) @ I <sub>F</sub> =12.5 A	V <sub>FM</sub>	1.2							Volts
Peak Reverse Current at Rated DC Blocking voltage	@ T <sub>c</sub> =25 °C	10							$\mu$ A
	@ T <sub>c</sub> =125 °C	1.0							mA
I <sup>2</sup> t Rating for Fusing (t<8.3ms) (Note 2)	I <sup>2</sup> t	373							A <sup>2</sup> s
Typical Junction Capacitance (Note 3)	C <sub>j</sub>	300							pF
Typical Thermal Resistance Junction to Case	R $\theta$ <sub>JA</sub>	3.8							°C/W
Operating and Storage Temperature Range	T <sub>j</sub> T <sub>STG</sub>	-65 to +150							°C

#### Notes:

- (1) Thermal resistance junction to case mounted on heat sink.
- (2) Measured at non-repetitive, for t > 1.0ms and < 8.3ms.
- (3) Measured at 1.0MHz and applied reverse voltage of 4.0V DC.

## RATINGS AND CHARACTERISTIC CURVES KBPC25005/W THRU KBPC2510/W

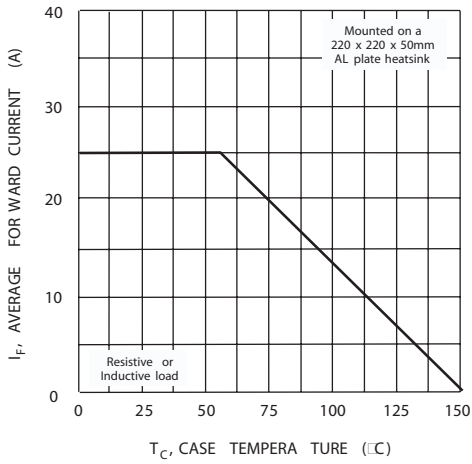

Fig. 1 Forward Current Derating Curve.

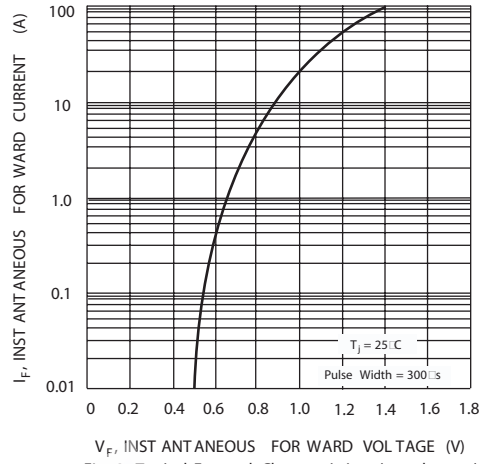

Fig. 2 Typical Forward Characteristics (per element)

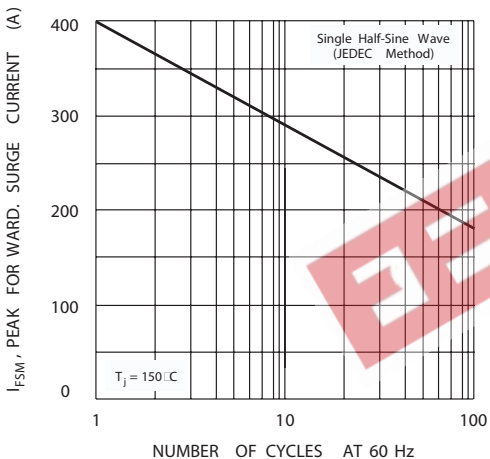

Fig. 3 Maximum Non-Repetitive Surge Current

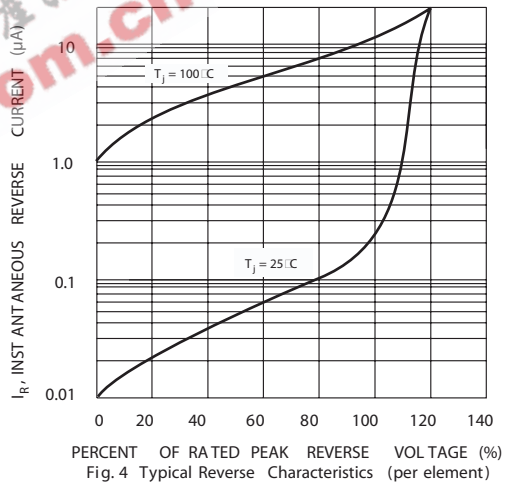

Fig. 4 Typical Reverse Characteristics (per element)