

November 22, 1999

TEL:805-498-2111 FAX:805-498-3804 WEB:http://www.semtech.com

**DESCRIPTION**

The EZ1587 series of high performance positive voltage regulators are designed for use in applications requiring low dropout performance at full rated current. Additionally, the EZ1587 series provides excellent regulation over variations in line, load and temperature.

Outstanding features include low dropout performance at rated current, fast transient response, internal current limiting and thermal shutdown protection of the output device. The EZ1587 series are three terminal regulators with fixed and adjustable voltage options available in popular packages.

**APPLICATIONS**

- Pentium® Processor supplies
- PowerPC™ supplies
- Other 1.3V to 5.7V microprocessor supplies
- Low voltage logic supplies
- Battery-powered circuitry
- Post regulator for switching supply

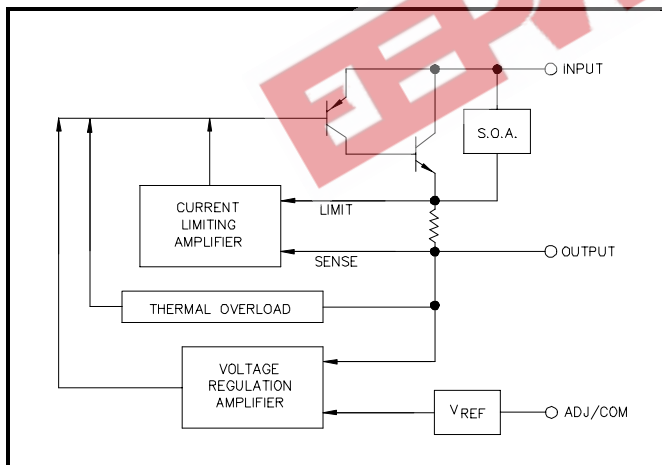
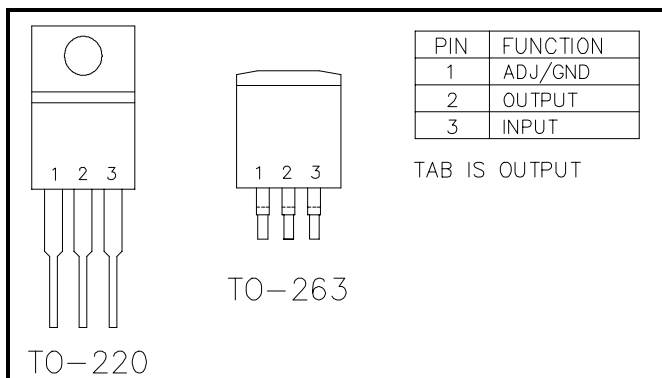
**BLOCK DIAGRAM**

**PIN CONFIGURATIONS**

**FEATURES**

- Low dropout performance, 1.3V max. for EZ1587
- Full current rating over line and temperature
- Fast transient response
- $\pm 2\%$  total output regulation over line, load and temperature
- Adjust pin current max. 90 $\mu$ A over temperature
- Fixed/adjustable output voltage
- Line regulation typically 0.005%
- Load regulation typically 0.05%
- TO-220 or TO-263 packages

**ORDERING INFORMATION**

DEVICE	PACKAGE	V <sub>OUT</sub> VOLTS
EZ1587CT-X.X	TO-220	See Note (1)
EZ1587CM-X.X	TO-263 <sup>(2)</sup>	See Note (1)

Notes:

(1) Where X.X denotes voltage options. Available voltages are: 1.5V, 1.8V, 2.5V, 3.3V and 3.45V. Leave blank for adjustable version (1.3 to 5.7V). Contact factory for additional voltage options.

(2) Add suffix 'TR' for tape and reel (TO-263).

**ABSOLUTE MAXIMUM RATINGS**

Parameter	Symbol	Maximum	Units
Input Supply Voltage	V <sub>IN</sub>	7	V
Power Dissipation	P <sub>D</sub>	Internally Limited	W
Thermal Resistance Junction to Case	$\theta_{JC}$	3	°C/W
TO-220			
TO-263		3	
Thermal Resistance Junction to Ambient	$\theta_{JA}$	50	°C/W
TO-220			
TO-263		60	
Operating Junction Temperature Range	T <sub>J</sub>	0 to 125	°C
Storage Temperature Range	T <sub>STG</sub>	-65 to 150	°C
Lead Temperature (Soldering) 10 Sec	T <sub>LEAD</sub>	260	°C

November 22, 1999

**ELECTRICAL CHARACTERISTICS**

 Unless otherwise specified, Adj  $V_{IN} = 2.75$  to  $7.0V$  and ADJ  $I_O = 10mA$  to  $3.0A$ ;  
 Fixed ( $V_{OUT} + 1.5$ ) to  $7.0V$  and Fixed  $I_O = 0mA$  to  $3.0A$ 

Parameter	Symbol	Test Conditions			Test Limits			Units	
		$V_{IN}$	$I_O$	$T_J^{(5)}$	Min	Typ	Max		
Output Voltage <sup>(1)</sup>	$V_O$	5V	10mA	25°C	0.99  $V_O$	$V_O$	1.01  $V_O$	V	
Fixed Voltage Version				O.T.	0.98  $V_O$	$V_O$	1.02  $V_O$		
Reference Voltage <sup>(1)</sup>	$V_{REF}$	5V	10mA	25°C	1.238	1.250	1.262	V	
Adj Voltage Version				O.T.	1.225	1.250	1.275		
Line Regulation <sup>(1)</sup>	$REG_{(LINE)}$			25°C		0.005	0.2	%	
Fixed Voltage Version				0mA	O.T.		0.035		0.2
Adj Voltage Version				10mA					
Load Regulation <sup>(1)</sup>	$REG_{(LOAD)}$	5V		25°C		0.05	0.3	%	
				O.T.			0.2		0.4
Dropout Voltage <sup>(2)</sup>	$V_D$			25°C		1		V	
EZ1587				O.T.			1.1		1.3
Current Limit	$I_{CL}$			O.T.	3.1	4.5		A	
Quiescent Current	$I_Q$	5V		O.T.		10	13	mA	
Fixed Voltage Version									
Temperature Coefficient	$T_C$			O.T.		0.004	0.02	%/°C	
Adjust Pin Current	$I_{ADJ}$			25°C		55		μA	
				O.T.					90
Adjust Pin Current Change	$\Delta I_{ADJ}$			O.T.		0.2	5	μA	
Temperature Stability	$T_S$	5V	0.5A	O.T.		0.5		%	
Minimum Load Current	$I_O$	5V		O.T.		5	10	mA	
Adj Voltage Version									
RMS Output Noise <sup>(3)</sup>	$V_N$			25°C		0.003		% $V_O$	
Ripple Rejection Ratio <sup>(4)</sup>	$R_A$	5V	3.0A	O.T.	60	72		dB	

**NOTES:**

- (1) Low duty cycle pulse testing with Kelvin connections required.
- (2)  $\Delta V_{OUT}, \Delta V_{REF} = 1\%$
- (3) Bandwidth of 10 Hz to 10 kHz.
- (4) 120 Hz input ripple, ( $C_{ADJ}$  for ADJ = 25μF).
- (5) Over Temp. (O.T.) = over specified operating junction temperature range.

November 22, 1999

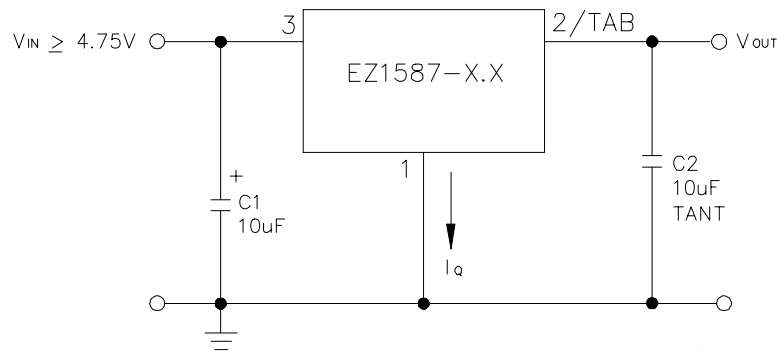
**TYPICAL APPLICATIONS**
**FIXED VOLTAGE REGULATOR <sup>(1)(2)</sup>**

- (1) C1 NEEDED IF DEVICE IS FAR FROM FILTER CAPACITORS.  
 (2) C2 REQUIRED FOR STABILITY.

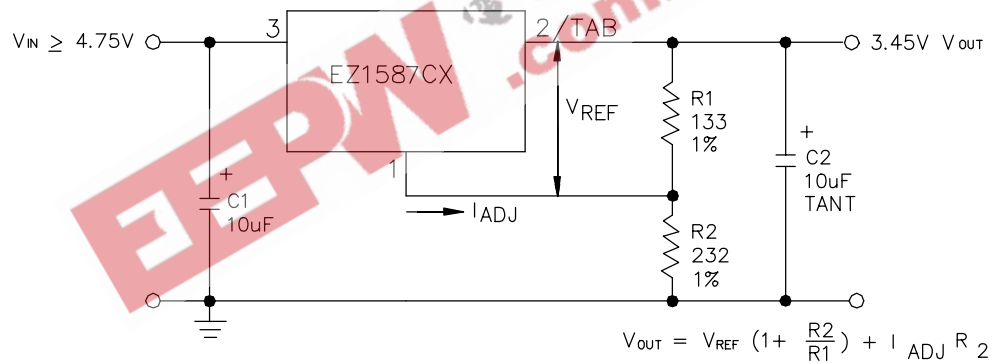
**ADJUSTABLE VOLTAGE REGULATOR <sup>(1)(2)</sup>**

- (1) C1 NEEDED IF DEVICE IS FAR FROM FILTER CAPACITORS.  
 (2) C2 REQUIRED FOR STABILITY.

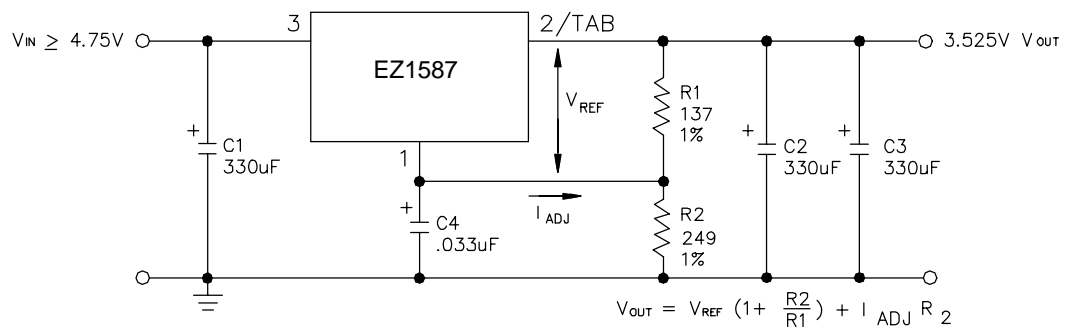
**RECOMMENDED CIRCUIT FOR THE INTEL  
 PENTIUM PROCESSOR® - P54C-VRE**

- (1) C1 NEEDED IF DEVICE IS FAR FROM FILTER CAPACITORS.  
 (2) C2 AND C3 REQUIRED FOR STABILITY.  
 (3) C1 = C2 = C3 = 330uF, 200m OHM ESR

November 22, 1999

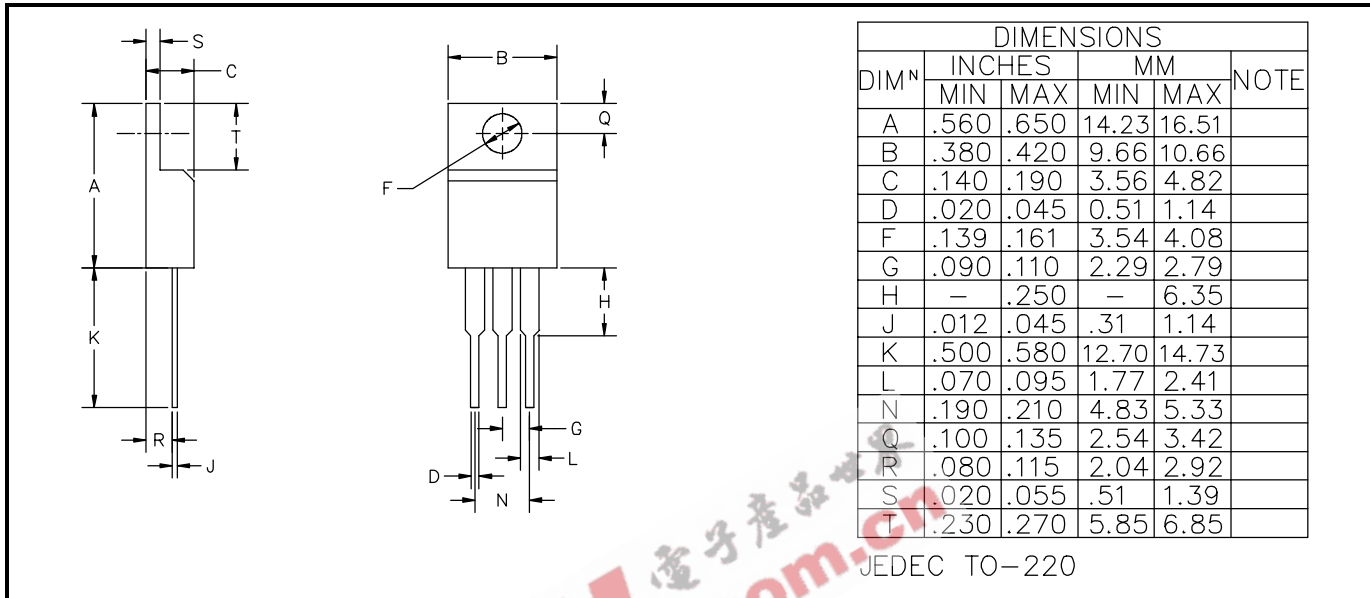
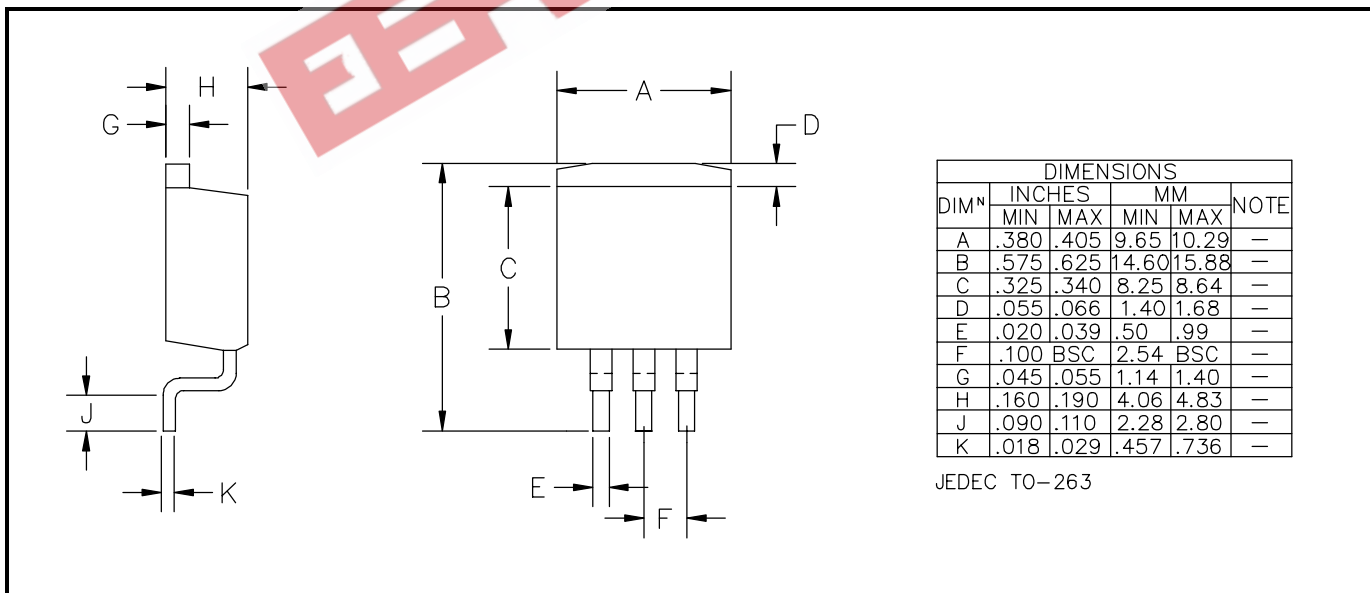
**DEVICE OUTLINE - TO-220**

**DEVICE OUTLINE - TO-263**

November 22, 1999

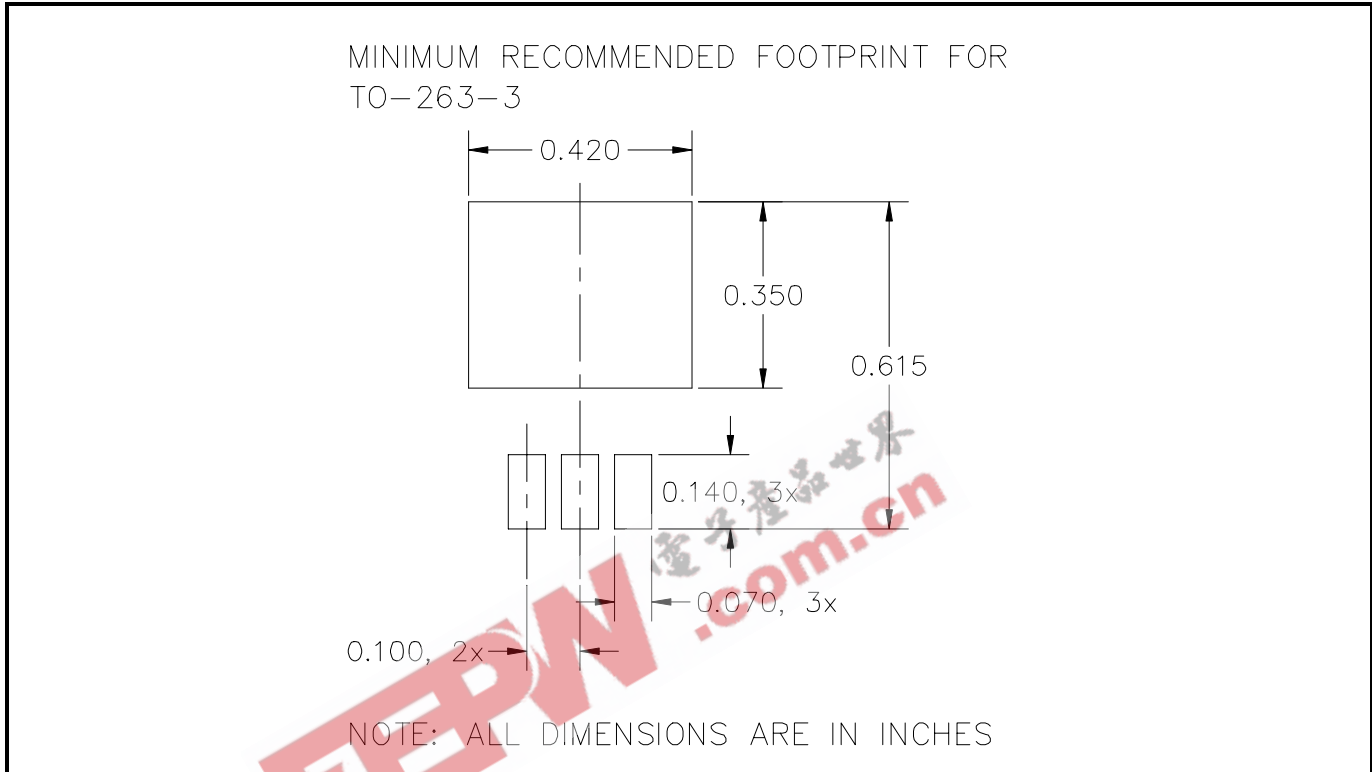
**LAND PATTERN - TO-263**



ECN99-734