

35.0-45.0 GHz GaAs Receiver QFN, 7x7 mm

Mimix
BROADBAND™

October 2006 - Rev 05-Oct-06

40REC0770-QB
RoHS

Features

- ✕ Sub-harmonic Receiver
- ✕ Integrated LNA, Image Reject Mixer, LO Doubler/Buffer
- ✕ +2.0 dBm LO Drive Level
- ✕ 8.0 dB Conversion Gain
- ✕ 4.0 dB NF
- ✕ +5.0 dBm Input Third Order Intercept (IP3)
- ✕ 7x7mm QFN package

General Description

Mimix Broadband's 35.0-45.0 GHz packaged receiver has a noise figure of 4.0 dB and 5.0 dBm Input Third Order Intercept across the band. This device integrates a three stage LNA followed by an image reject resistive pHEMT mixer and includes an integrated LO doubler and buffer amplifier. The use of integrated LO doubler and LO buffer amplifier makes the provision of the LO easier than for fundamental mixers at these frequencies. I and Q mixer outputs are provided and an external 90 degree hybrid is required to select the desired sideband. The device comes in a 7x7mm QFN package that is RoHS compliant. This device is well suited for Millimeter-wave Point-to-Point Radio, LMDS, SATCOM and VSAT applications.



Absolute Maximum Ratings

Supply Voltage (Vd)	+6.0 VDC
Supply Current (Id)	300 mA
Gate Bias Voltage (Vg)	+0.3 VDC
Input Power (RF Pin)	+5 dBm
Storage Temperature (Tstg)	-65 to +165 °C
Operating Temperature (Ta)	-55 to MTTF Table ¹
Channel Temperature (Tch)	MTTF Table ¹

(1) Channel temperature affects a device's MTTF. It is recommended to keep channel temperature as low as possible for maximum life.

Electrical Characteristics (Ambient Temperature T = 25° C)

Parameter	Units	Min.	Typ.	Max.
Frequency Range (RF)	GHz	35.0	-	45.0
Frequency Range (LO)	GHz	16.0	-	24.0
Frequency Range (IF)	GHz	DC	-	4.0
Input Return Loss RF (S11)	dB	-	10.0	-
Small Signal Conversion Gain RF/IF (S21)	dB	-	8.0	-
LO Input Drive (PLO)	dBm	-	+2.0	-
Image Rejection	dBc	-	20.0	-
Noise Figure (NF)	dB	-	4.0	-
Isolation LO/RF @ LOx1/LOx2	dB	-	40.0/40.0	-
Input Third Order Intercept (IIP3)	dBm	-	+5.0	-
Input 1 dB Compression (IP1dB)	dBm	-	-5.0	-
Drain Bias Voltage (Vd)	VDC	-	+4.0	+5.5
Gate Bias Voltage (Vg1,2)	VDC	-1.2	-0.5	+0.1
Supply Current (Id) (Vd=4.0, Vg=-0.3V Typical)	mA	-	180	240

35.0-45.0 GHz GaAs Receiver

QFN, 7x7 mm



October 2006 - Rev 05-Oct-06

40REC0770-QB
 RoHS

Measurements

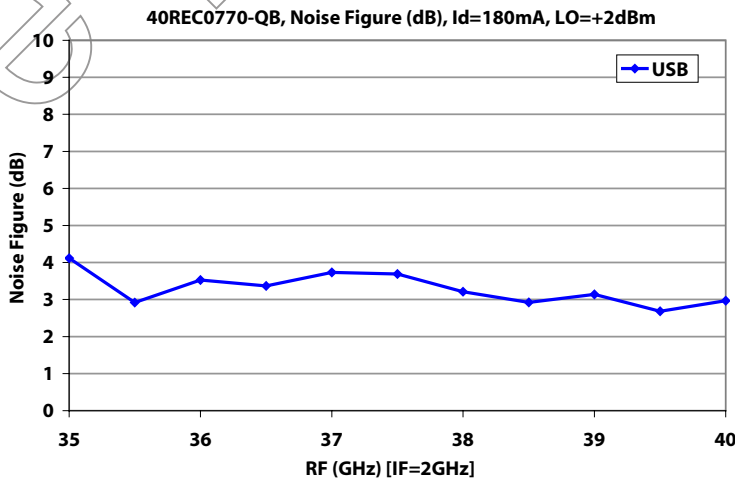
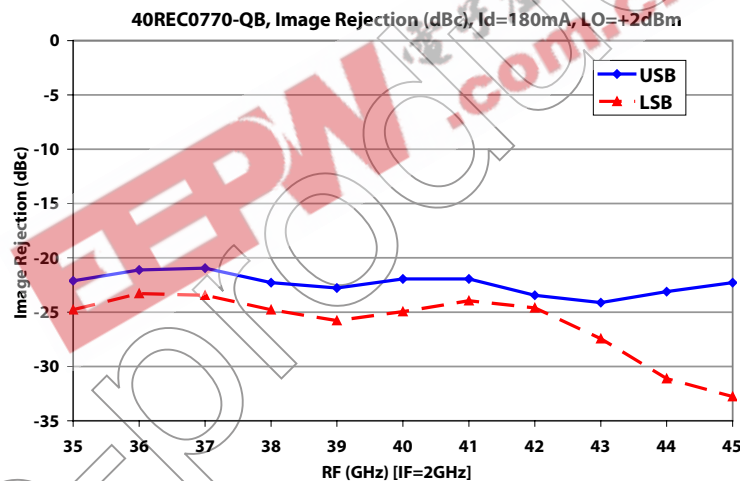
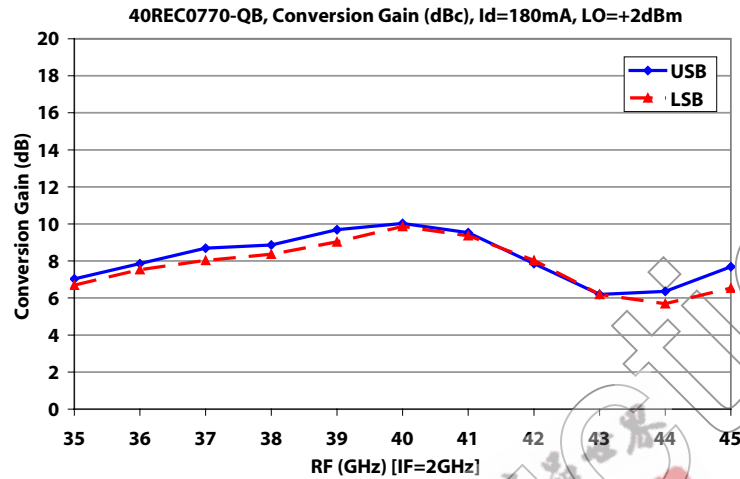

Mimix Broadband, Inc., 10795 Rockley Rd., Houston, Texas 77099
 Tel: 281.988.4600 Fax: 281.988.4615 mimixbroadband.com

Page 2 of 7

Characteristic Data and Specifications are subject to change without notice. ©2006 Mimix Broadband, Inc.
 Export of this item may require appropriate export licensing from the U.S. Government. In purchasing these parts, U.S. Domestic customers accept their obligation to be compliant with U.S. Export Laws.

35.0-45.0 GHz GaAs Receiver

QFN, 7x7 mm

October 2006 - Rev 05-Oct-06

40REC0770-QB
RoHS

Physical Dimensions

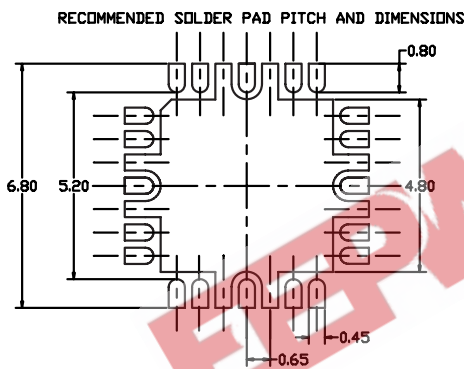
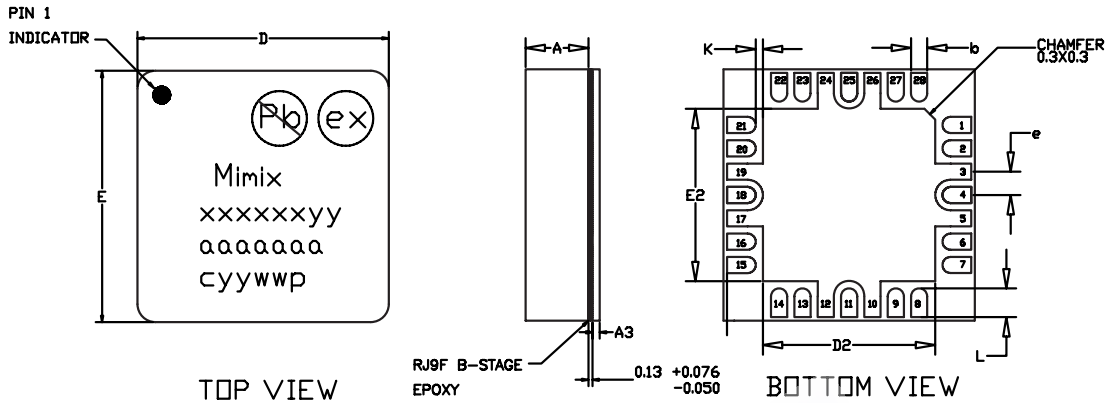

Note:

1. ALL DIMENSIONS ARE IN mm.

	MIN	TYP	MAX
A	1.70	1.75	1.80
A3	0.20 REF		
b	0.40	0.45	0.50
K	0.41	-	-
D	7.00 BSC		
E	7.00 BSC		
e	0.65		
D2	4.75	4.80	4.85
E2	4.35	4.40	4.45
L	0.75	0.80	0.85

(Note: Engineering designator is 40REC0770)

Functional Schematic

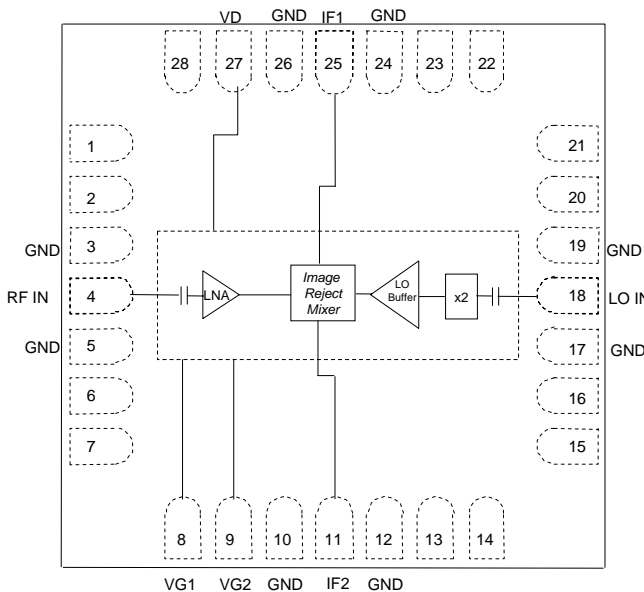

Pin Designations

Pin Number	Pin Name	Pin Function	Nominal Value	Unit
3	GND	Ground		
4	RF IN	RF Input		
5	GND	Ground		
8	VG1	LNA, LO Amp	-0.5	volts
9	VG2	Mixer, Doubler	-0.5	volts
10	GND	Ground		
11	IF2	IF2 Output		
12	GND	Ground		
17	GND	Ground		
18	LO IN	LO Input	2.0	dBm
19	GND	Ground		
24	GND	Ground		
25	IF1	IF1 Output		
26	GND	Ground		
27	VD	Drain Bias	4.0	volts
All other pins	NC	Not Connected		

35.0-45.0 GHz GaAs Receiver QFN, 7x7 mm

October 2006 - Rev 05-Oct-06

Mimix
BROADBAND™

40REC0770-QB
RoHS

Recommended Layout

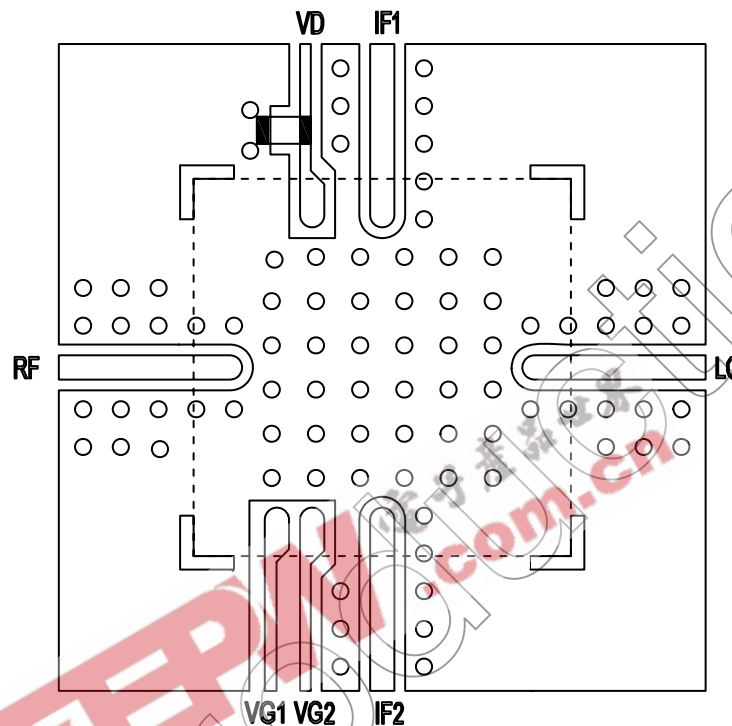

Mimix Broadband, Inc., 10795 Rockley Rd., Houston, Texas 77099
Tel: 281.988.4600 Fax: 281.988.4615 mimixbroadband.com

Page 4 of 7

Characteristic Data and Specifications are subject to change without notice. ©2006 Mimix Broadband, Inc.
Export of this item may require appropriate export licensing from the U.S. Government. In purchasing these parts, U.S. Domestic customers accept their obligation to be compliant with U.S. Export Laws.

35.0-45.0 GHz GaAs Receiver

QFN, 7x7 mm

October 2006 - Rev 05-Oct-06

40REC0770-QB
RoHS

App Note [1] Biasing - The device is operated by biasing $V_D=4.0V$ with $I_D=180\text{ mA}$. Additionally, a mixer and doubler bias are also required with $V_{G2}=-0.5V$. Adjusting V_{g2} above or below this value can adversely affect conversion gain, image rejection and intercept point performance. It is recommended to use active biasing to keep the currents constant as the RF power and temperature vary; this gives the most reproducible results. Depending on the supply voltage available and the power dissipation constraints, the bias circuit may be a single transistor or a low power operational amplifier, with a low value resistor in series with the drain supply used to sense the current. The gate of the pHEMT is controlled to maintain correct drain current and thus drain voltage. The typical gate voltage needed to do this is $-0.3V$. Typically the gate is protected with Silicon diodes to limit the applied voltage. Also, make sure to sequence the applied voltage to ensure negative gate bias is available before applying the positive drain supply.

MTTF

MTTF is calculated from accelerated life-time data of single devices and assumes an isothermal back-plate.

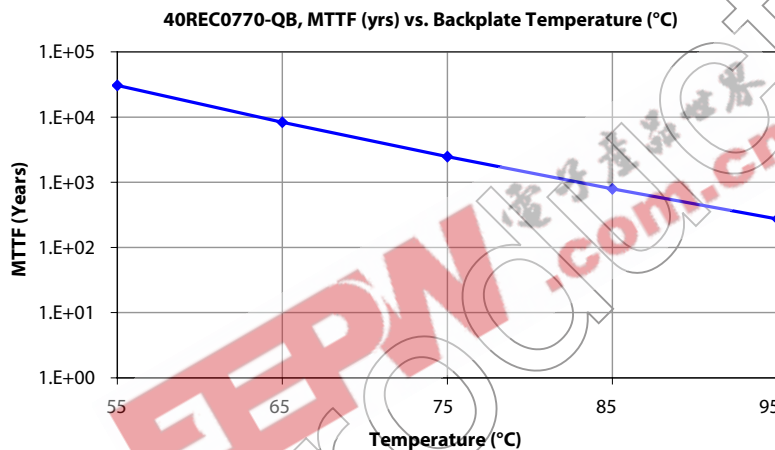

Bias Conditions: $V_D=4.0V, I_D=180\text{ mA}$

Typical Application

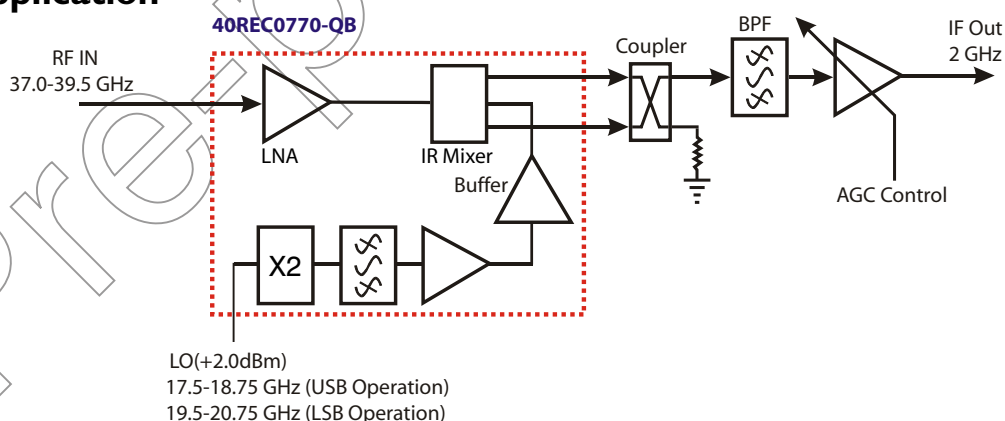

Mimix Broadband MMIC-based 35.0-45.0 GHz Receiver Block Diagram

(Changing LO and IF frequencies as required allows design to operate as high as 46 GHz)

Mimix Broadband's 30.0-46.0 GHz 40REC0770-QB GaAs MMIC Receiver can be used in saturated radio applications and linear modulation schemes up to 128 QAM.

35.0-45.0 GHz GaAs Receiver QFN, 7x7 mm

October 2006 - Rev 05-Oct-06

40REC0770-QB
RoHS

App Note [3] USB/LSB Selection -

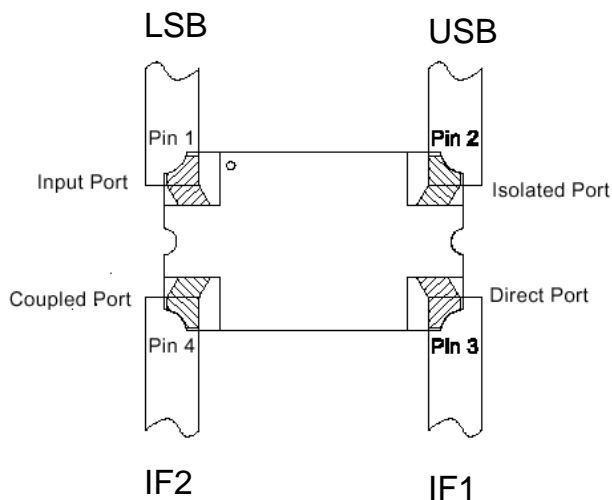

For Upper Side Band operation (USB):

With IF1 and IF2 connected to the direct port (0°) and coupled port (90°) respectively as shown in the diagram, the USB signal will reside on the isolated port. The input port must be loaded with 50 ohms.

For Lower Side Band operation (LSB):

With IF1 and IF2 connected to the direct port (0°) and coupled port (90°) respectively as shown in the diagram, the LSB signal will reside on the input port. The isolated port must be loaded with 50 ohms.

An alternate method of Selection of USB or LSB:

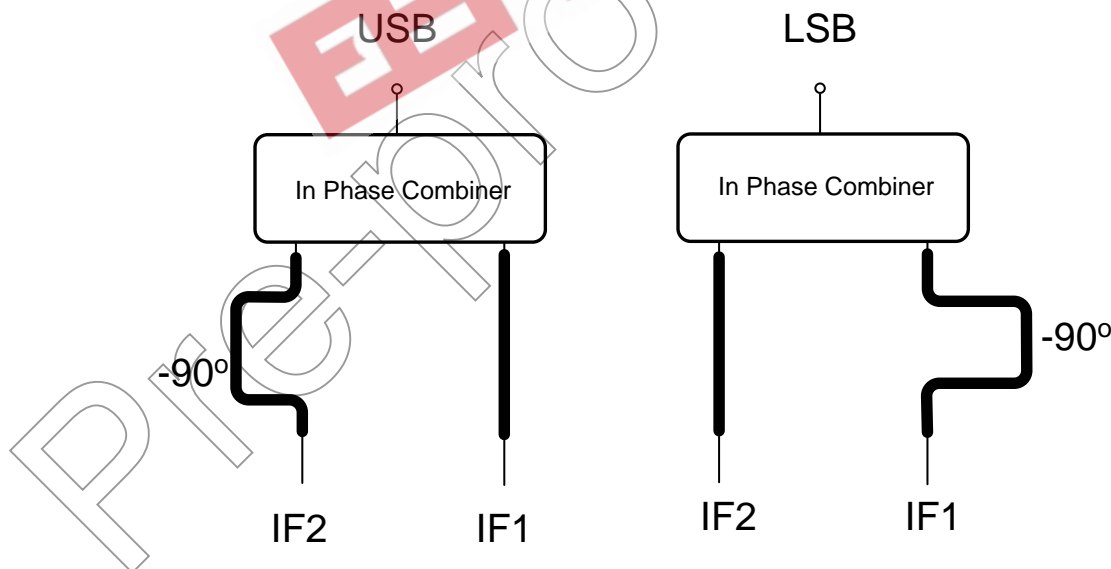

35.0-45.0 GHz GaAs Receiver QFN, 7x7 mm



October 2006 - Rev 05-Oct-06

40REC0770-QB
X RoHS

Handling and Assembly Information

CAUTION! - Mimix Broadband MMIC Products contain gallium arsenide (GaAs) which can be hazardous to the human body and the environment. For safety, observe the following procedures:

- Do not ingest.
- Do not alter the form of this product into a gas, powder, or liquid through burning, crushing, or chemical processing as these by-products are dangerous to the human body if inhaled, ingested, or swallowed.
- Observe government laws and company regulations when discarding this product. This product must be discarded in accordance with methods specified by applicable hazardous waste procedures.

Life Support Policy - Mimix Broadband's products are not authorized for use as critical components in life support devices or systems without the express written approval of the President and General Counsel of Mimix Broadband. As used herein: (1) Life support devices or systems are devices or systems which, (a) are intended for surgical implant into the body, or (b) support or sustain life, and whose failure to perform when properly used in accordance with instructions for use provided in the labeling, can be reasonably expected to result in a significant injury to the user. (2) A critical component is any component of a life support device or system whose failure to perform can be reasonably expected to cause the failure of the life support device or system, or to affect its safety or effectiveness.

Package Attachment - This packaged product from Mimix Broadband is provided as a rugged surface mount package compatible with high volume solder installation. The package is a low-cost plastic package. Vacuum tools or other suitable pick and place equipment may be used to pick and place this part. Care should be taken to ensure that there are no voids or gaps in the solder connection so that good RF, DC and ground connections are maintained. Voids or gaps can eventually lead not only to RF performance degradation, but reduced reliability and life of the product due to thermal stress.

Typical Reflow Profiles

Reflow Profile	SnPb	Pb Free
Ramp Up Rate	3-4 °C/sec	3-4 °C/sec
Activation Time and Temperature	60-120 sec @ 140-160 °C	60-180 sec @ 170-200 °C
Time Above Melting Point	60-150 sec	60-150 sec
Max Peak Temperature	240 °C	265 °C
Time Within 5 °C of Peak	10-20 sec	10-20 sec
Ramp Down Rate	4-6 °C/sec	4-6 °C/sec

Mimix Lead-Free RoHS Compliant Program - Mimix has an active program in place to meet customer and governmental requirements for eliminating lead (Pb) and other environmentally hazardous materials from our products. All Mimix RoHS compliant components are form, fit and functional replacements for their non-RoHS equivalents. Lead plating of our RoHS compliant parts is 100% matt tin (Sn) over copper alloy and is backwards compatible with current standard SnPb low-temperature reflow processes as well as higher temperature (260°C reflow) "Pb Free" processes.

Part Number for Ordering Description

40REC0770-QB-0L00	Ni/Pd/Au plated RoHS compliant QFN 7x7 28L surface mount package in bulk quantity
40REC0770-QB-0L0T	Ni/Pd/Au plated RoHS compliant QFN 7x7 28L surface mount package in tape and reel
40REC0770-QB-EV1	40REC0770-QB Evaluation Module

We also offer this part with alternative plating options. Please contact your regional sales manager for more information regarding different plating types.