



KBL601 THRU KBL607

Single Phase 6.0 AMPS. Silicon Bridge Rectifiers



Voltage Range
50 to 1000 Volts
Current
6.0 Amperes

Features

- ✧ UL Recognized File # E-96005
- ✧ Ideal for printed circuit board
- ✧ Reliable low cost construction
- ✧ High surge current capability
- ✧ High temperature soldering guaranteed:
260°C / 10 seconds / 0.375" (9.5mm)
lead length at 5 lbs., (2.3 kg) tension
- ✧ Leads solderable per MIL-STD-202,
Method 208

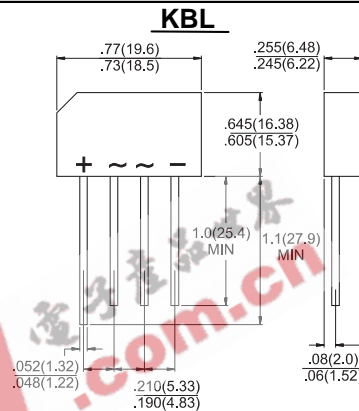

Dimensions in inches and (millimeters)

Maximum Ratings and Electrical Characteristics

Rating at 25°C ambient temperature unless otherwise specified.

Single phase, half wave, 60 Hz, resistive or inductive load.

For capacitive load, derate current by 20%

Type Number	Symbol	KBL 601	KBL 602	KBL 603	KBL 604	KBL 605	KBL 606	KBL 607	Units
Maximum Recurrent Peak Reverse Voltage	V_{RRM}	50	100	200	400	600	800	1000	V
Maximum RMS Voltage	V_{RMS}	35	70	140	280	420	560	700	V
Maximum DC Blocking Voltage	V_{DC}	50	100	200	400	600	800	1000	V
Maximum Average Forward Rectified Current @ $T_A = 50^\circ\text{C}$ (Note 1)	$I_{(AV)}$	6.0							A
Peak Forward Surge Current, 8.3 ms Single Half Sine-wave Superimposed on Rated Load (JEDEC method)	I_{FSM}	200							A
Maximum Instantaneous Forward Voltage @ 6.0A	V_F	1.1							V
Maximum DC Reverse Current @ $T_A=25^\circ\text{C}$ at Rated DC Blocking Voltage @ $T_A=100^\circ\text{C}$	I_R	10 500							uA uA
Typical thermal Resistance (Note 1) (Note 2)	$R_{\theta JA}$ $R_{\theta JL}$	19 2.4							$^{\circ}\text{C/W}$
Operating Temperature Range T_J	T_J	-55 to +125							$^{\circ}\text{C}$
Storage Temperature Range T_{STG}	T_{STG}	-55 to +150							$^{\circ}\text{C}$

Note: 1. Thermal Resistance from Junction to Ambient Al-Plate.

2. Thermal resistance from Junction to Lead with units Mounted on P.C.B. at 0.375" (9.5mm) Lead Length and 0.6" x 0.6" (16mm x 16mm) Copper Pads.



RATINGS AND CHARACTERISTIC CURVES (KBL601 THRU KBL607)

FIG.1- MAXIMUM NON-REPETITIVE FORWARD SURGE CURRENT PER BRIDGE ELEMENT

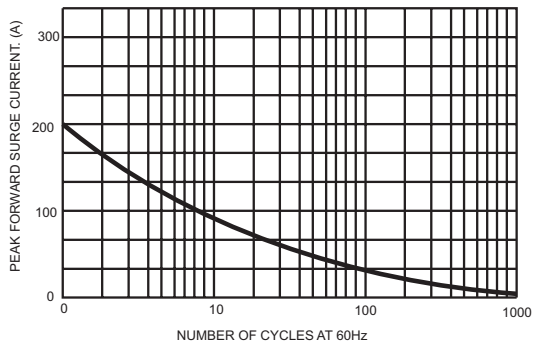

FIG.2- MAXIMUM FORWARD CURRENT DERATING CURVE

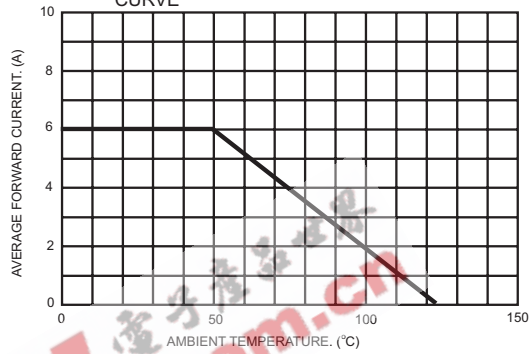

FIG.3- TYPICAL INSTANTANEOUS FORWARD CHARACTERISTICS PER BRIDGE ELEMENT

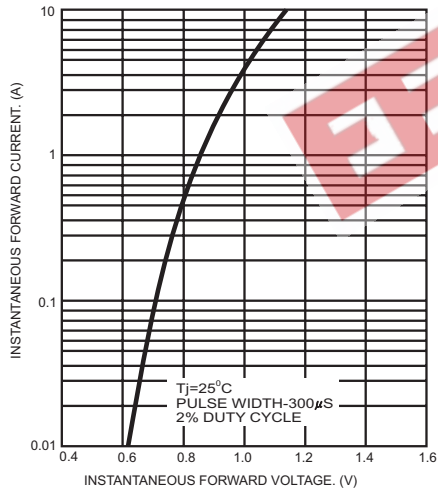

FIG.4- TYPICAL REVERSE CHARACTERISTICS PER BRIDGE ELEMENT

