



# STK401-020

## AF Power Amplifier (Split Power Supply) (15 W + 15 W min, THD = 0.4%)

### Overview

Now, thick-film audio power amplifier ICs are available with pin-compatibility to permit a single PCB to be designed and amplifier output capacity changed simply by installing a hybrid IC. This new series was developed with this kind of pin-compatibility to ensure integration between systems everywhere. With this new series of IC, even changes from 3-channel amplifier to 2-channel amplifiers is possible using the same PCB. In addition, this new series of ICs has a  $6/3\Omega$  drive in order to support the low impedance of modern speakers.

### Features

- Pin-compatible  
STK400-000 series (3-channel/single package)  
↓  
STK401-000 series (2-channel/single package)
- Output load impedance  $RL=6\Omega/3\Omega$  supported
- New pin arrangement  
To simplify input/output pattern layout and minimize the effects of pattern layout on operational characteristics, pin assignments are grouped into blocks consisting of input, output and power systems.
- Few external circuits  
Compared to those series used until now, boot-strap capacitors and boot-strap resistors for external circuits can be greatly reduced.

### Package Dimensions

unit: mm

4134

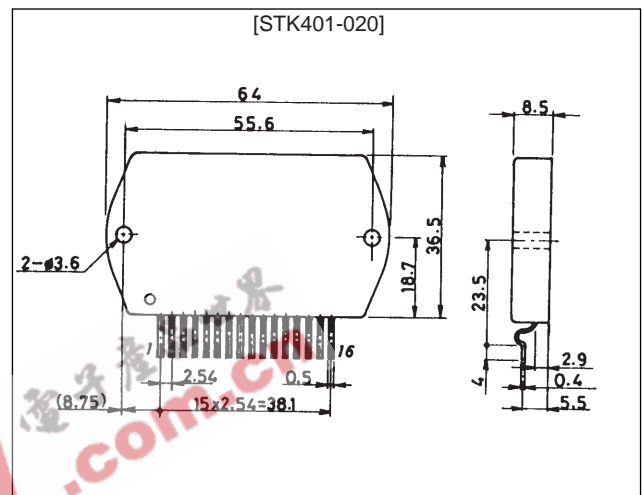

### Specifications

#### Maximum Ratings at $T_a = 25^\circ\text{C}$

Parameter	Symbol	Conditions	Ratings	Unit
Maximum supply voltage	$V_{CC \text{ max}}$		$\pm 29$	V
Thermal resistance	$\theta_{j-c}$	Per power transistor	2.1	$^\circ\text{C}/\text{W}$
Junction temperature	$T_j$		150	$^\circ\text{C}$
Operating substrate temperature	$T_c$		125	$^\circ\text{C}$
Storage temperature range	$T_{\text{stg}}$		-30 to +125	$^\circ\text{C}$
Permissible load short time	$t_s$	$V_{CC} = \pm 20 \text{ V}$ , $R_L = 6 \Omega$ , $f = 50 \text{ Hz}$ , $P_O = 15 \text{ W}$	1	s

**Operating Characteristics at  $T_a = 25^\circ\text{C}$ ,  $R_L = 6\ \Omega$ ,  $R_g = 600\ \Omega$ ,  $V_G = 40\text{dB}$ ,  $R_L$  (non-inductive)**

Parameter	Symbol	Conditions	min	typ	max	Unit
Quiescent current	$I_{CCO}$	$V_{CC} \pm 24\text{ V}$	20	60	100	mA
Output power	$P_o$ (1)	$V_{CC} \pm 20\text{ V}$ , $f = 20\text{ to }20\text{ kHz}$ , $\text{THD} = 0.4\%$	15	20		W
	$P_o$ (2)	$V_{CC} \pm 16\text{ V}$ , $f = 1\text{ kHz}$ , $\text{THD} = 1.0\%$ , $R_L = 3\ \Omega$	15	20		W
Total harmonic distortion	THD (1)	$V_{CC} \pm 20\text{ V}$ , $f = 20\text{ to }20\text{ kHz}$ , $P_o = 1.0\text{ W}$			0.4	%
	THD (2)	$V_{CC} \pm 20\text{ V}$ , $f = 1\text{ kHz}$ , $P_o = 5.0\text{ W}$		0.02		%
Frequency response	$f_L, f_H$	$V_{CC} \pm 20\text{ V}$ , $P_o = 1.0\text{ W}$ , $+0_{-3}\text{ dB}$		20 to 50 k		Hz
Input impedance	$r_i$	$V_{CC} \pm 20\text{ V}$ , $f = 1\text{ kHz}$ , $P_o = 1.0\text{ W}$		55		k $\Omega$
Output noise voltage	$V_{NO}$	$V_{CC} \pm 24\text{ V}$ , $R_g = 10\text{ k}\Omega$			1.2	mVrms
Neutral voltage	$V_N$	$V_{CC} \pm 24\text{ V}$	-70	0	70	mV

**Notes**

- Use rated power supply for test unless otherwise specified.
- When measuring permissible load short time and output noise voltage use transformer power supply indicated below.
- Output noise voltage is represented by the peak value rms (VTVM) for mean reading. Use an AC stabilized power supply (50 Hz) on the primary side to eliminate the effect of AC flicker noise.

**Specified Transformer Power Supply (RP-22 Equivalent)**

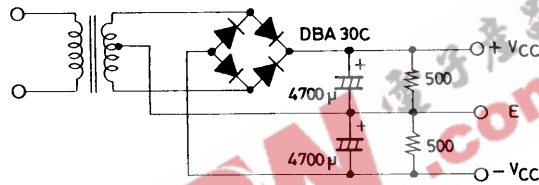

Unit (resistance:  $\Omega$ , capacitance: F)

**Internal Equivalent Circuit**

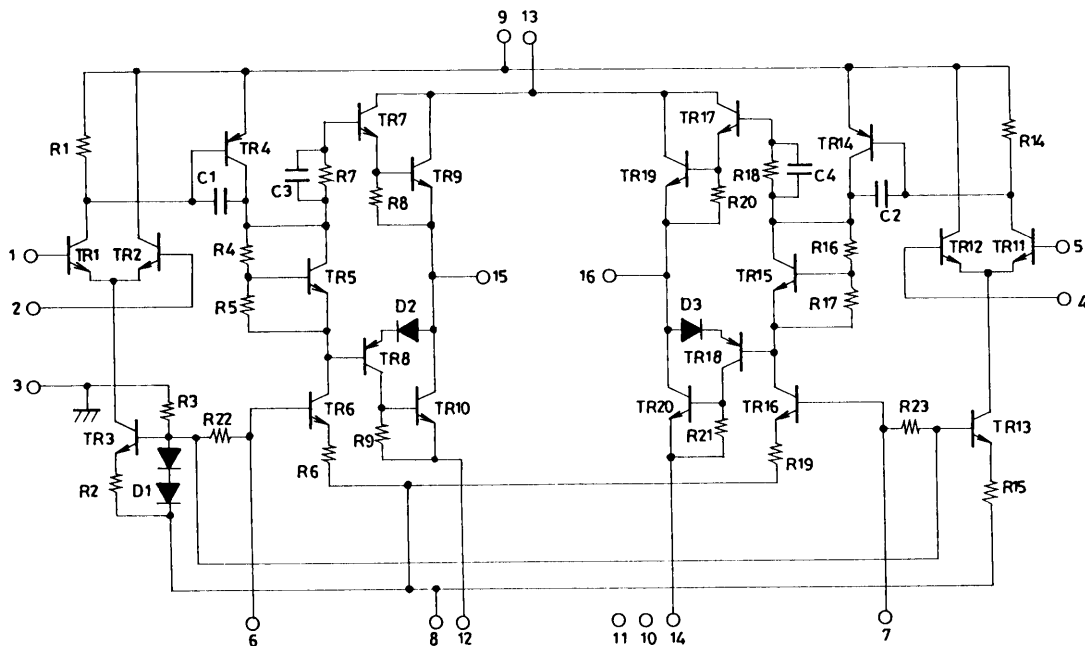

Pattern Example for PCB used with either 2- or 3-channel Amplifiers.

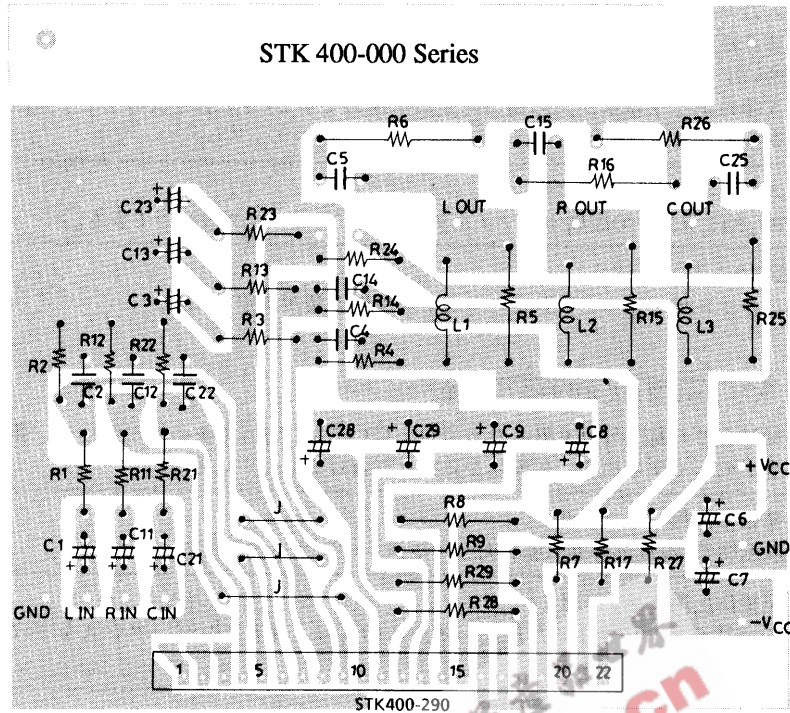

Copper (Cu) foil surface

With the STK401-000 series, the 6 pin corresponds to the 1 pin with respect to the STK400-000 series.

Sample Application Circuit

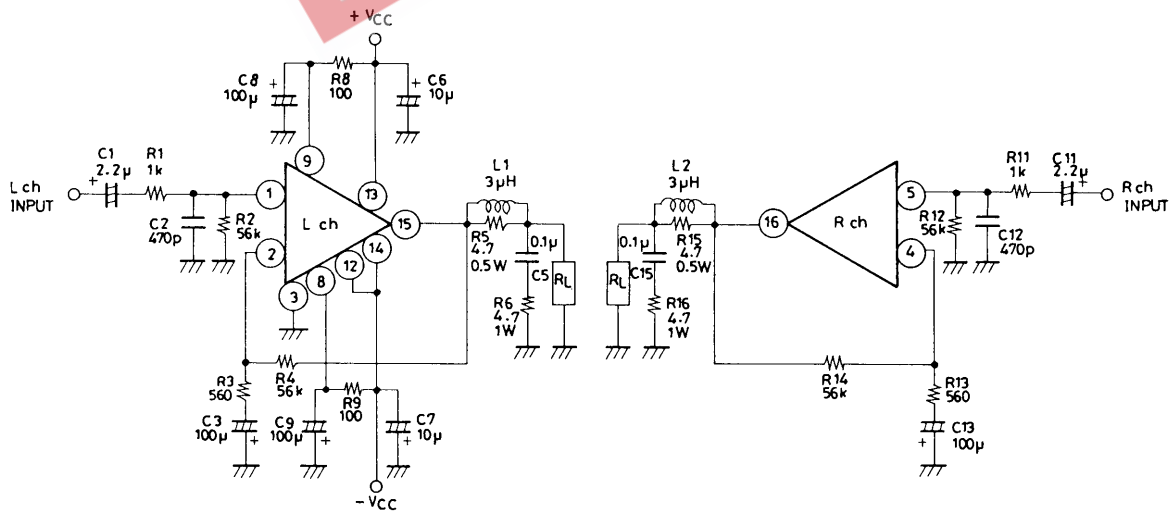

Unit (resistance:  $\Omega$ , capacitance: F)

**Description of External Circuits**

C1, 11	For input coupling capacitor. Used for DC current blocking. When capacitor reactance with low frequency is increased, the reactance value should be reduced in order to reduce the output noise from the signal resistance dependent 1/f noise. In response to the popping noise which occurs when the system power is turned on, C1 and C11 which determine the decay time constant on the input side are increased while C3 and C13 on the NF side are decreased.
C2, 12	For input filter capacitor. Permits high-region noise reduction by utilizing filter constructed with R1 and R11.
C3, 13	For NF capacitor. This capacitor determines the decline of the cut-off frequency and is calculated according to the following equation. $f_L = \frac{1}{2\pi \times C3 (13) \times R3 (13)}$ <p>For the purpose of achieving voltage gains prior to reduction, it is best that C3 and C13 are large. However, because the shock noise which occurs when the system power is turned on tends to increase, values larger than those absolutely necessary should be avoided.</p>
C5, 15	For oscillation prevention capacitor. A Mylar capacitor with temperature and frequency features is recommended.
C6, 7	For oscillation prevention capacitor. To ensure safe IC functioning, the capacitor should be installed as close as possible to the IC power pin to reduce power impedance. An electrolytic capacitor is good.
C8, 9	For decoupling capacitor. Reduces shock noise during power up using decay time constant circuits with R8 and R9 and eliminates components such as ripples crossing over into the input side from the power line.
R1, 11	For input filter applied resistor.
R2, 12	For input bias resistor. The input pin is biased to zero potential. Input impedance is mostly decided with this resistance value.
R3, 13, 4, 14	For resistors to determine voltage gain (VG). We recommend a VG = 40 dB using R3 and R13 = 560Ω and R4 and R14 = 56Ω. VG adjustments are best performed using R3 and R13. When using R4 and R14 for such purposes, R4 and R14 should be set to equal R2 and R12 in order to establish a stable VN balance.
R5, 15	For oscillation prevention resistor.
R6, 16	For oscillation prevention resistor. This resistor's electrical output resides in the signal frequency and is calculated according to the following formula. $P R6 (16) = \left( \frac{V_{CC} \max/\sqrt{2}}{1/2\pi f C5 (15) + R6 (16)} \right)^2 \times R6 (16)$ <p>f = output signal frequency upper limit</p>
R8, 9	For ripple filter applied resistor. PO max, ripple rejection and power-up shock noise are modified according to this value. Set the electrical output of these resistors while keeping in mind the flow of peak current during recharging to C8 and C9 which function as pre-drive TR control resistors during load shorts.
L1, 2	For oscillation prevention coil. Compensates phase dislocation caused by load capacitors and ensures stable oscillation.

# STK401-020

## Series Configuration

3ch Amp IC Name	Fixed Standard Output	2ch Amp IC Name	Fixed Standard Output	THD [%] f = 20 to 20kHz	Supply voltage [V]			
					V <sub>CC</sub> max1	V <sub>CC</sub> max2	V <sub>CC</sub> 1	V <sub>CC</sub> 2
STK400-010	10W X 3	STK401-010	10W X 2	0.4	±29.0	±27	±18	±14
STK400-020	15W X 3	STK401-020	15W X 2		±30.5	±29	±20	±16
STK400-030	20W X 3	STK401-030	20W X 2		±34.5	±34	±23	±19
STK400-040	25W X 3	STK401-040	25W X 2		±40.0	±36	±25	±21
STK400-050	30W X 3	STK401-050	30W X 2		±42.0	±39	±26	±22
STK400-060	35W X 3	STK401-060	35W X 2		±45.0	±41	±28	±23
STK400-070	40W X 3	STK401-070	40W X 2		±48.0	±44	±30	±24
STK400-080	45W X 3	STK401-080	45W X 2		±50.0	±45	±31	±25
STK400-090	50W X 3	STK401-090	50W X 2		±52.5	±47	±32	±26
STK400-100	60W X 3	STK401-100	60W X 2		±55.0	±51	±35	±27
STK400-110	70W X 3	STK401-110	70W X 2		±56.0	—	±38	—
—	—	STK401-120	80W X 2		±61.0	—	±42	—
—	—	STK401-130	100W X 2		±65.0	—	±45	—
—	—	STK401-140	120W X 2		±74.0	—	±51	—

V<sub>CC</sub> max1      R<sub>L</sub> = 6Ω  
 V<sub>CC</sub> max2      R<sub>L</sub> = 6Ω to 3Ω  
 V<sub>CC</sub>1            R<sub>L</sub> = 6Ω  
 V<sub>CC</sub>2            R<sub>L</sub> = 3Ω

## Example of Set Design for Common PCB

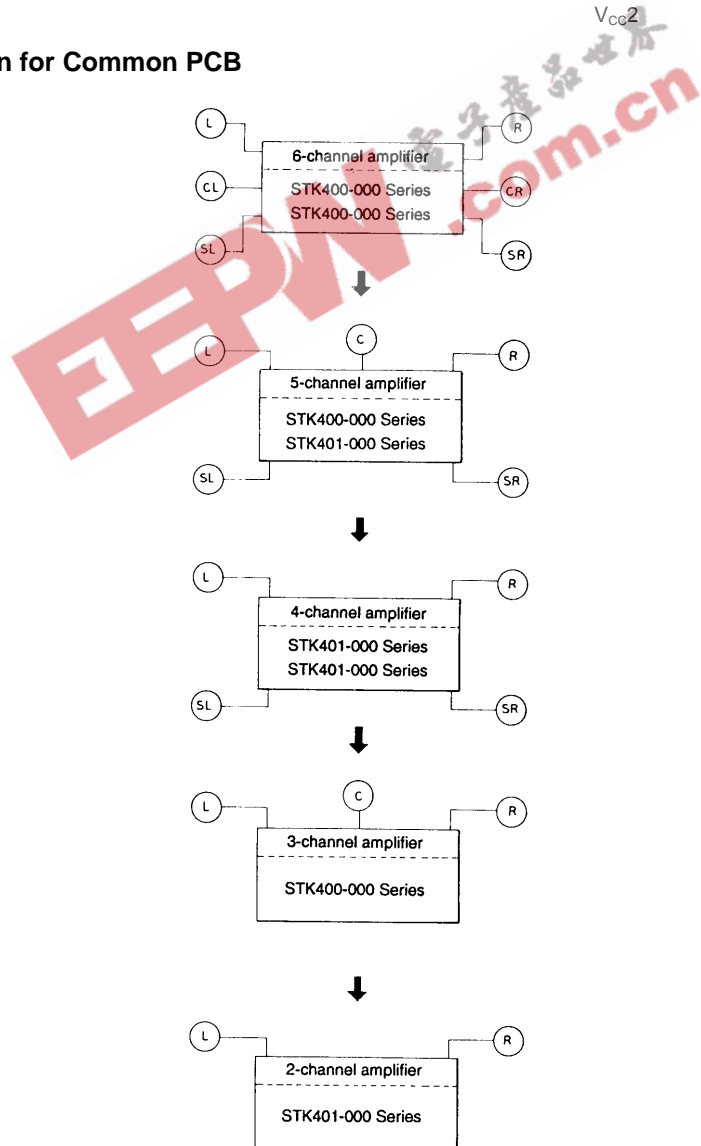

External Circuit Diagram

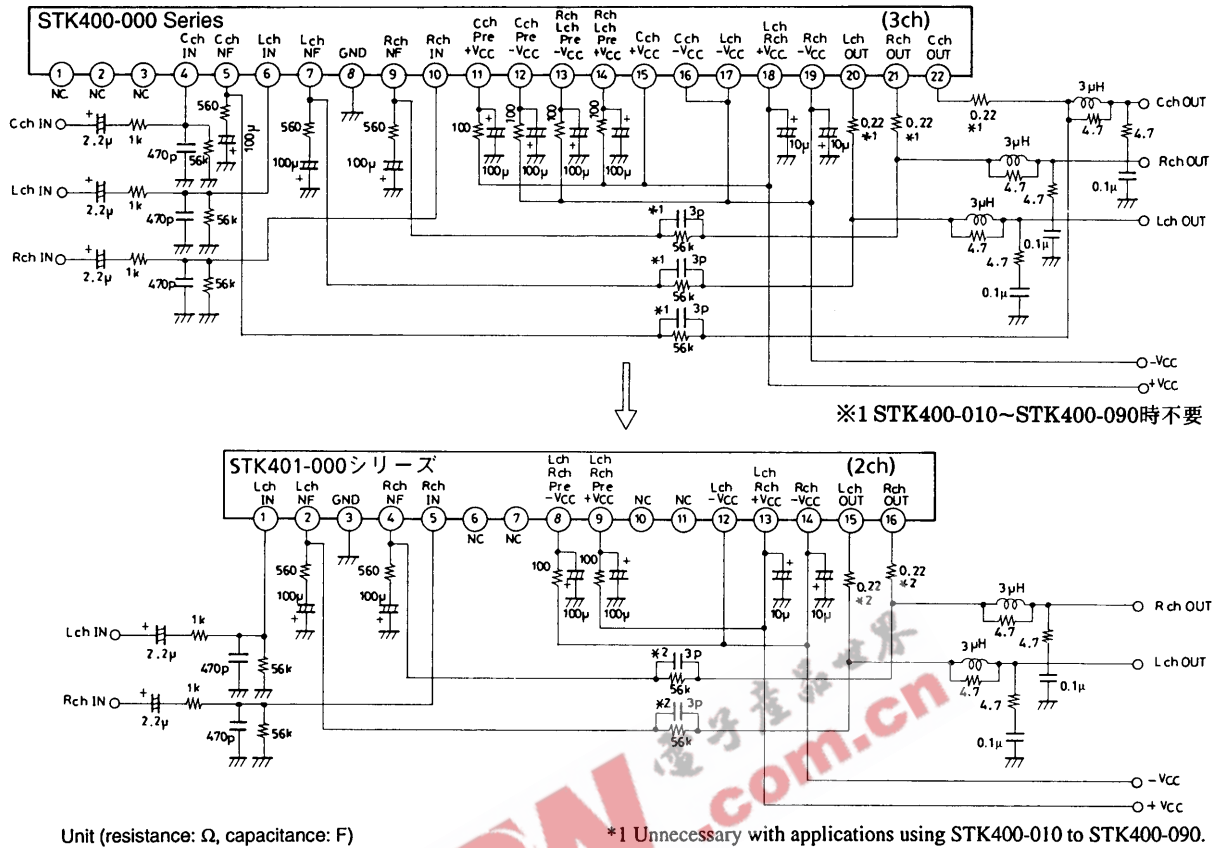

Heat Radiation Design Considerations

The radiator thermal resistance  $\theta_{c-a}$  required for total substrate power dissipation  $P_d$  in the STK401-020 is determined as:

Condition 1: IC substrate temperature  $T_c$  not to exceed 125°C.

$$P_d \times \theta_{c-a} + T_a < 125^\circ\text{C} \dots\dots\dots (1)$$

where  $T_a$  is set assured ambient temperature.

Condition 2: Power transistor junction temperature  $T_j$  not to exceed 150°C.

$$P_d \times \theta_{c-a} + P_d/N \times \theta_{j-c} + T_a < 150^\circ\text{C} \dots\dots\dots (2)$$

where  $N$  is the number of power transistors and  $\theta_{j-c}$  is the thermal resistance per power transistor chip. However, power transistor power consumption is  $P_d$  equally divided by  $N$  units.

Expressions (1) and (2) can be rewritten based on  $\theta_{c-a}$  to yield:

$$\theta_{c-a} < (125 - T_a) / P_d \dots\dots\dots (1')$$

$$\theta_{c-a} < (150 - T_a) / (P_d - \theta_{j-c} / N) \dots\dots\dots (2')$$

The required radiator thermal resistance will satisfy both of these expressions.

From expressions (1)' and (2)', the required radiator thermal resistance can be determined once the following specifications are known:

- Supply voltage  $V_{CC}$
- Load resistance  $R_L$
- Assured ambient temperature  $T_a$

The total substrate power consumption when STK401-020  $V_{CC}$  is  $\pm 20$  V and  $R_L$  is 6 Ω, for a continuous sine wave signal, is a maximum of 27.5W (Fig. 1). In general, when this sort of continuous signal is used for estimation of power consumption, the  $P_d$  used is 1/10th of  $P_o$  max (slight variation depending on safety standard).

$$P_d = 15.7\text{W} \text{ (1/10 } P_o \text{ max=during 1.5W)}$$

The STK401-020 has four power transistors, so the thermal resistance per transistor  $\theta_{j-c}$  is  $2.1^{\circ}\text{C} / \text{W}$ . With an assured ambient temperature  $T_a$  of  $50^{\circ}\text{C}$ , the required radiator thermal resistance  $\theta_{c-a}$  would be:

From expression (1)'  $\theta_{c-a} < (125-50)/15.7$   
 $< 4.78$

From expression (2)'  $\theta_{c-a} < (150-50)/15.7-2.1/4$   
 $< 5.84$

To satisfy both,  $4.78^{\circ}\text{C}/\text{W}$  is the required radiator thermal resistance.

Figure 2 illustrates  $P_d - P_o$  when the  $V_{CC}$  of STK401-020 is  $\pm 16\text{V}$  and  $R_L$  is functioning at  $3\Omega$ .

$P_d = 17.6\text{W}$  ( $1/10 P_o \text{ max} = \text{during } 1.5\text{W}$ )

From expression (1)'  $\theta_{c-a} < (125-50)/17.6$   
 $< 4.26$

From expression (2)'  $\theta_{c-a} < (150-50)/17.6-2.1/4$   
 $< 5.16$

To satisfy both,  $4.26^{\circ}\text{C} / \text{W}$  is the required radiator thermal resistance. This design example is based on a fixed voltage supply, and will require verification within your specific set environment.

Figure 1

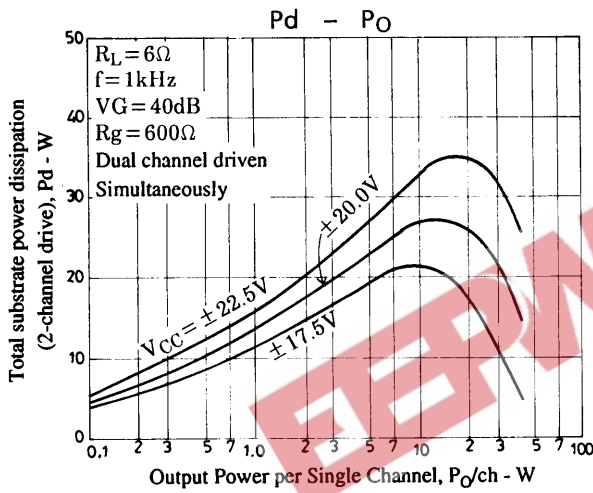
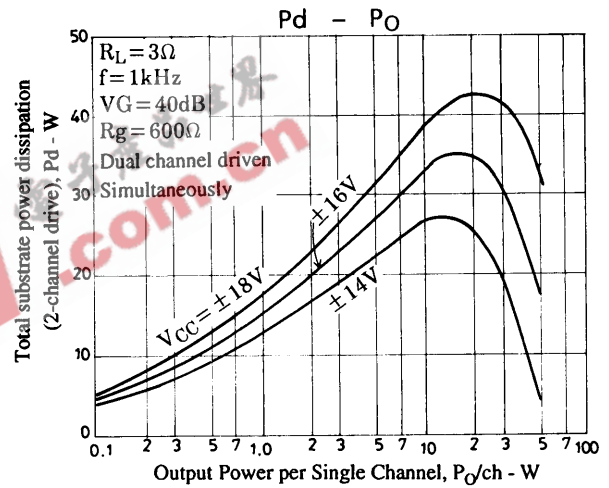
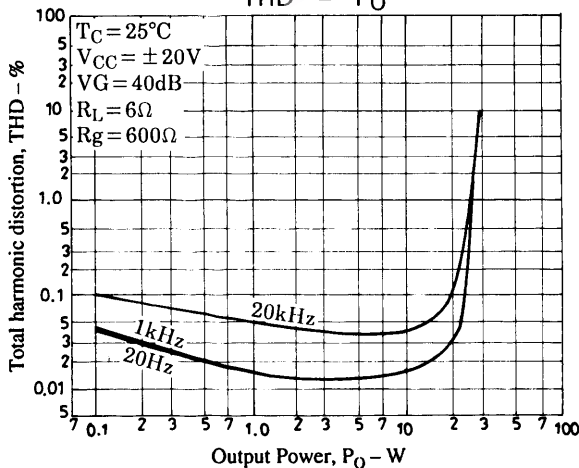

Figure 2



THD - Po



THD - Po

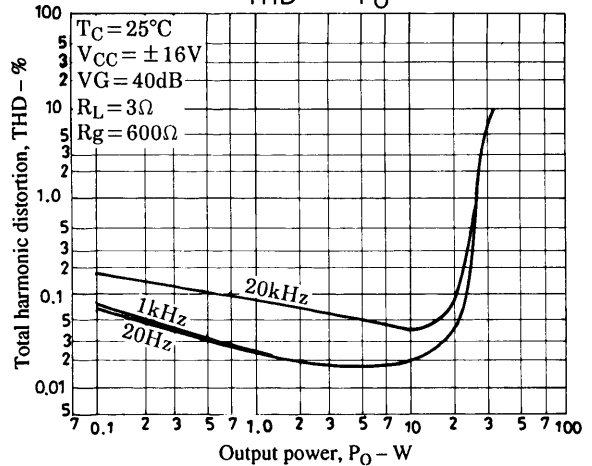

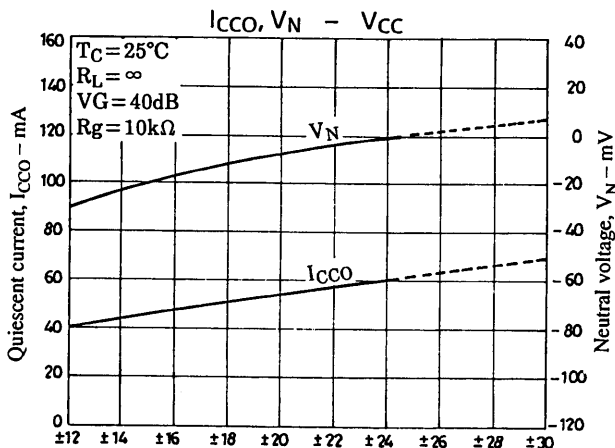
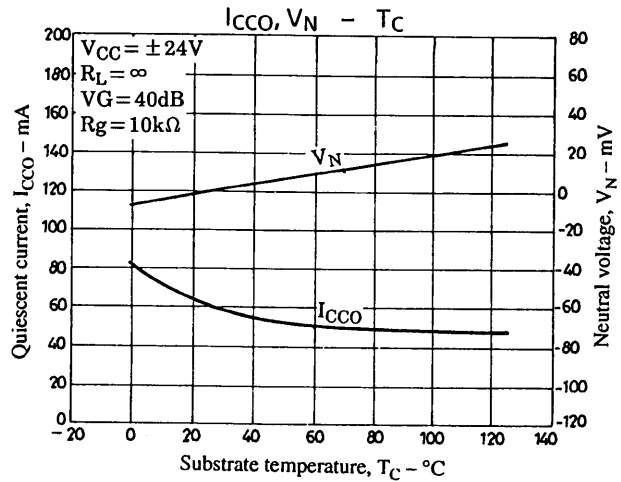
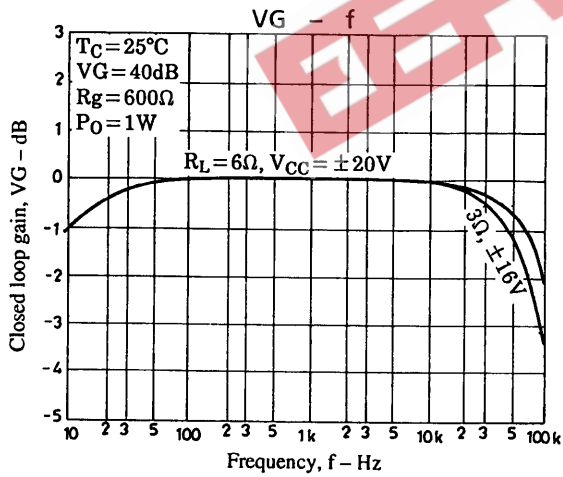
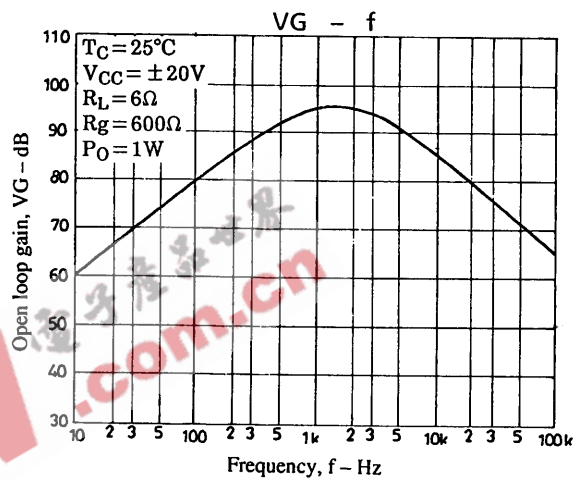
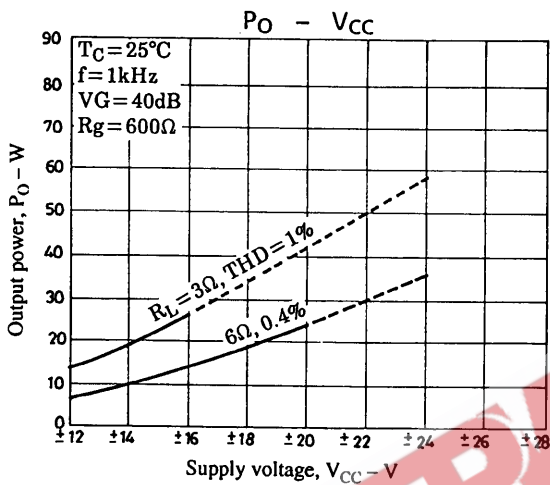
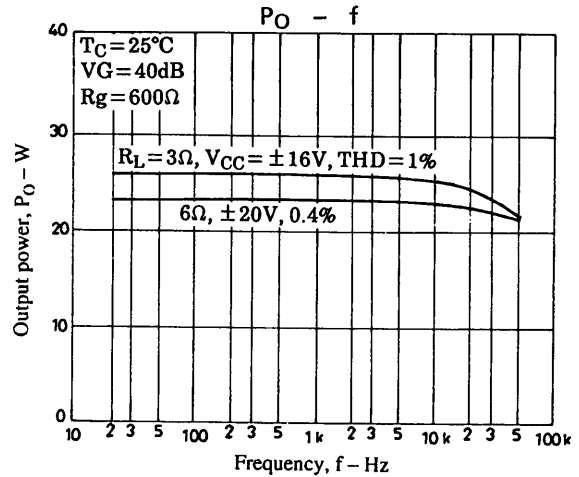
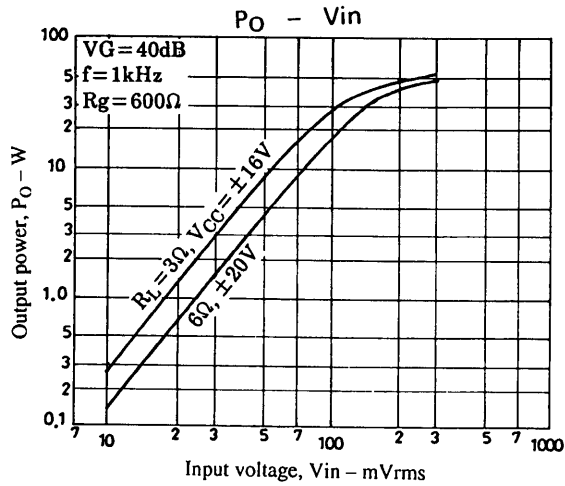



EEPW 电子產品世界  
.com.cn

- No products described or contained herein are intended for use in surgical implants, life-support systems, aerospace equipment, nuclear power control systems, vehicles, disaster/crime-prevention equipment and the like, the failure of which may directly or indirectly cause injury, death or property loss.
- Anyone purchasing any products described or contained herein for an above-mentioned use shall:
  - ① Accept full responsibility and indemnify and defend SANYO ELECTRIC CO., LTD., its affiliates, subsidiaries and distributors and all their officers and employees, jointly and severally, against any and all claims and litigation and all damages, cost and expenses associated with such use:
  - ② Not impose any responsibility for any fault or negligence which may be cited in any such claim or litigation on SANYO ELECTRIC CO., LTD., its affiliates, subsidiaries and distributors or any of their officers and employees jointly or severally.
- Information (including circuit diagrams and circuit parameters) herein is for example only; it is not guaranteed for volume production. SANYO believes information herein is accurate and reliable, but no guarantees are made or implied regarding its use or any infringements of intellectual property rights or other rights of third parties.

This catalog provides information as of August, 1997. Specifications and information herein are subject to change without notice.