

**SANYO**

No. 4898

**STK401-140**

**Two-Channel AF Power Amplifier**  
 (± power supply)  
**120 W + 120 W Minimum, THD = 0.4%**

## Overview

A major feature of Sanyo thick-film power amplifier ICs is that all ICs within a given product series are pin compatible. This allows users to construct a product line of amplifiers with differing power output capacities using the same PCB design by simply changing the hybrid IC used. Sanyo has now developed a new series that expands this intra-series pin compatibility to also provide compatibility between certain series. Adoption of the ICs in this new series also allows the development of both two- and three-channel amplifiers on the same PCB. Furthermore, this new series supports 3 and 6 Ω drive to handle the recent trend toward lower impedance speakers.

## Features

- Pin compatibility  
STK400-000 Series (three channels/one package)  
↓  
STK401-000 Series (two channels/one package)
- Support for output load impedances of 3 or 6 Ω
- New pin assignment  
The new pin assignment groups the input, output, and power supply systems into separate blocks. This minimizes characteristic degradation due to problems with the PCB pattern layout.
- Minimal number of required external components  
The bootstrap resistor and capacitor required in earlier series are no longer necessary.

## Package Dimensions

unit: mm

4029

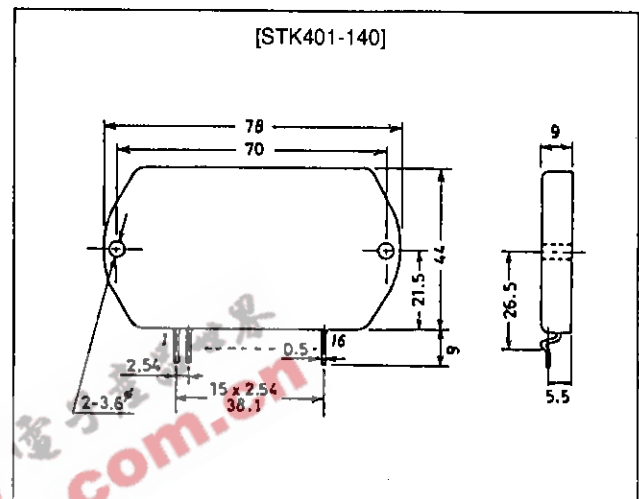

## Specifications

### Maximum Ratings at Ta = 25°C

Parameter	Symbol	Conditions	Ratings	Unit
Maximum supply voltage	V <sub>CC max</sub>		±74	V
Thermal resistance	θ <sub>j-c</sub>	Per power transistor	1.0	°C/W
Junction temperature	T <sub>j</sub>		150	°C
Operating substrate temperature	T <sub>c</sub>		125	°C
Storage temperature range	T <sub>stg</sub>		-30 to +125	°C
Available time for load shorted	t <sub>s</sub>	V <sub>CC</sub> = ±51 V, R <sub>L</sub> = 6 Ω, f = 50 Hz, P <sub>O</sub> = 120 W	0.5	s

**SANYO Electric Co., Ltd. Semiconductor Business Headquarters**

TOKYO OFFICE: Tokyo Bldg., 1-10, 1-Chome, Ueno, Taito-ku, TOKYO, 110 JAPAN

Operating Characteristics at  $T_a = 25^\circ\text{C}$ ,  $R_L = 6 \Omega$ ,  $R_g = 600 \Omega$ ,  $V_G = 40 \text{ dB}$ , and with a noninductive load ( $R_L$ )

Parameter	Symbol	Conditions	min	typ	max	Unit
Quiescent current	$I_{CCO}$	$V_{CC} = \pm 61 \text{ V}$	20	60	100	mA
Output power	$P_O$	$V_{CC} = \pm 51 \text{ V}$ , $f = 20 \text{ Hz to } 20 \text{ kHz}$ , $\text{THD} = 0.4\%$	120	140		W
Total harmonic distortion	THD (1)	$V_{CC} = \pm 51 \text{ V}$ , $f = 20 \text{ Hz to } 20 \text{ kHz}$ , $P_O = 1.0 \text{ W}$			0.4	%
	THD (2)	$V_{CC} = \pm 51 \text{ V}$ , $f = 1 \text{ kHz}$ , $P_O = 30 \text{ W}$		0.02		%
Frequency characteristics	$f_L, f_H$	$V_{CC} = \pm 51 \text{ V}$ , $P_O = 1.0 \text{ W}$ , $+0$ $-3 \text{ dB}$		20 to 50 k		Hz
Input impedance	$r_i$	$V_{CC} = \pm 51 \text{ V}$ , $f = 1 \text{ kHz}$ , $P_O = 1.0 \text{ W}$		55		$k\Omega$
Output noise voltage	$V_{NO}$	$V_{CC} = \pm 61 \text{ V}$ , $R_g = 10 \text{ k}\Omega$			1.2	mVrms
Neutral voltage	$V_N$	$V_{CC} = \pm 61 \text{ V}$	-70	0	+70	mV

Notes

1. Use a rated power supply for the test unless otherwise noted.
2. Use the specified transformer power supply shown in the figure when measuring the available time for load shorted and the output noise voltage.
3. The output noise voltage is the peak value measured with an averaging rms scale volt meter (VTVM). A 50 Hz AC stabilized power supply should be used to eliminate the effects of AC primary line flicker noise when an AC power supply is used.

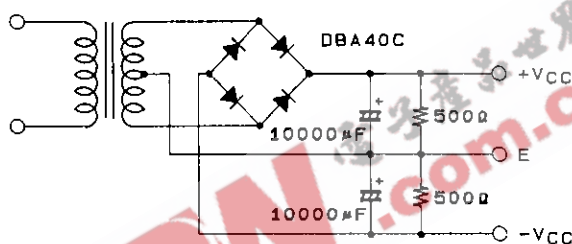

A01361

Specified Transformer Power Supply (MG-250 equivalent)

Internal Equivalent Circuit

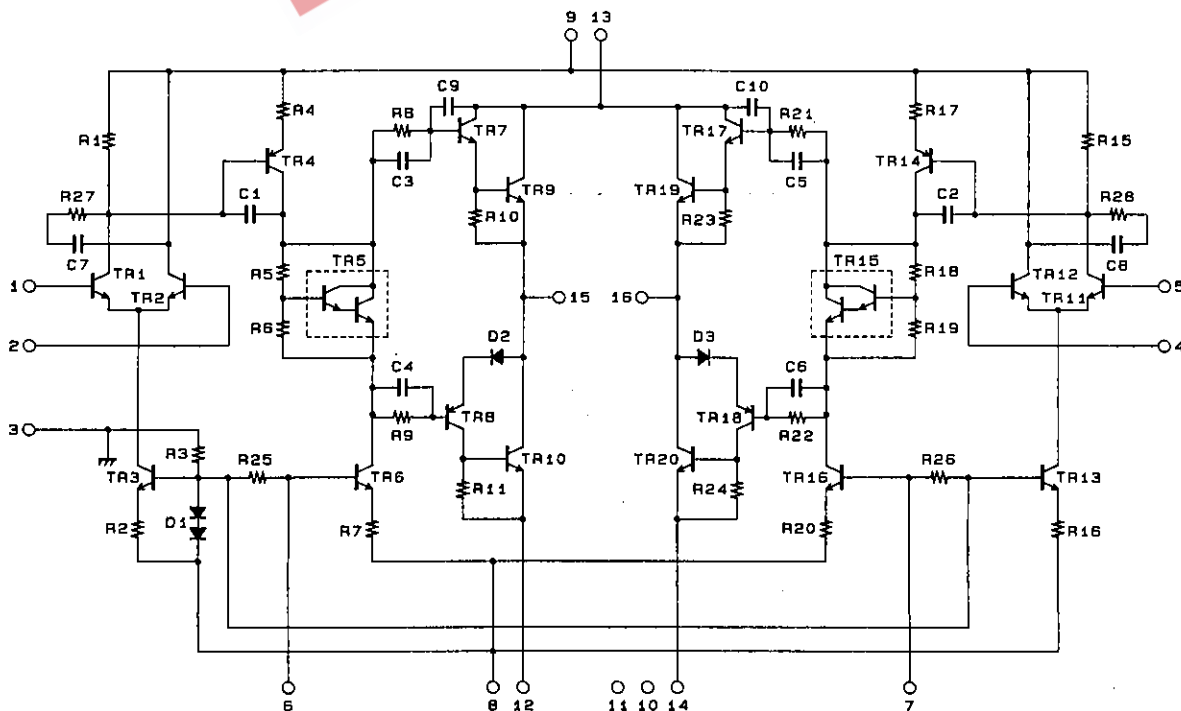

A02707

Sample PCB Pattern used with either Two- or Three-Channel Amplifier

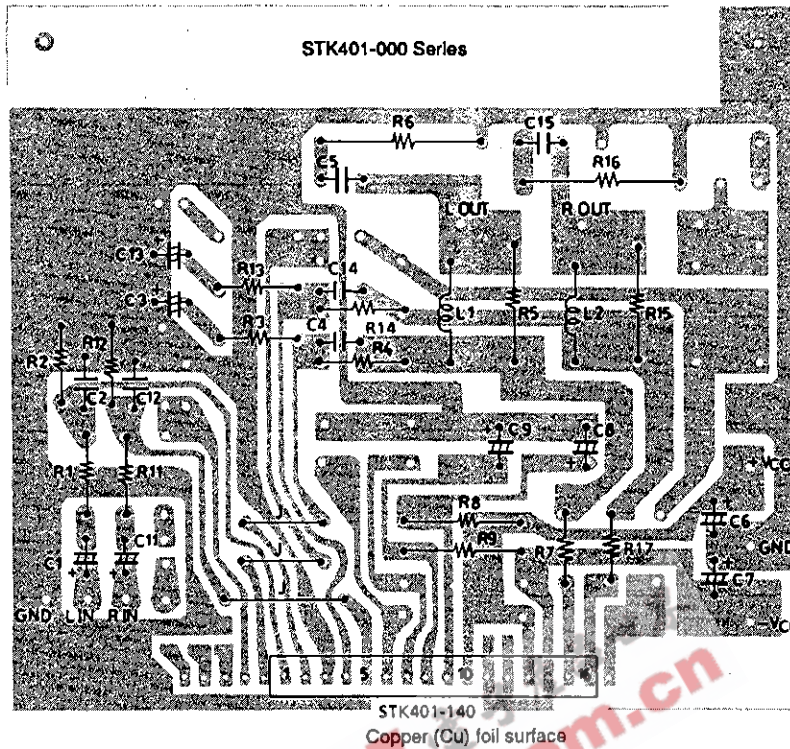

Pin 1 in the STK401-000 Series corresponds to pin 6 in the STK400-000 Series.

Sample Application Circuit

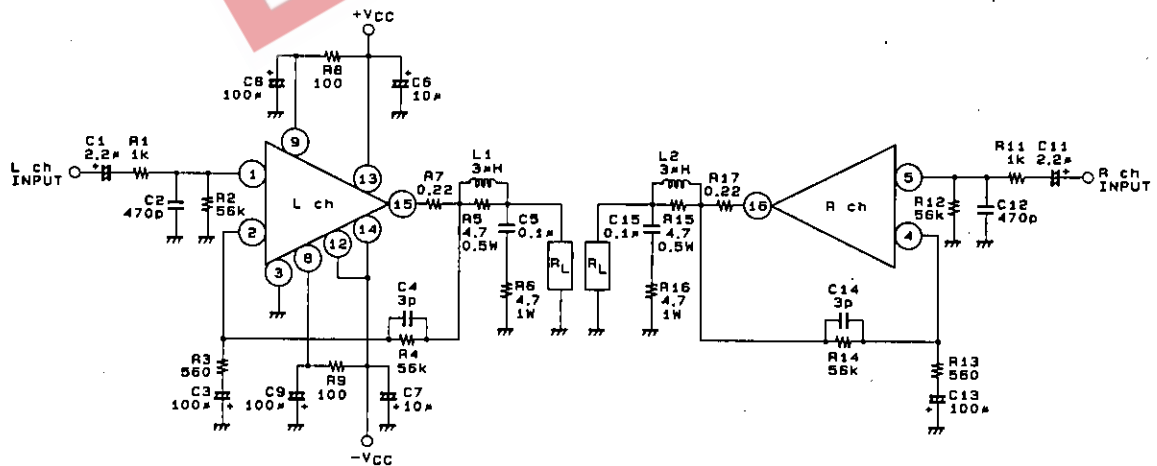

A01637

Units (resistance:  $\Omega$ , capacitance: F)

External Component Descriptions

Item	Function
C1, C11	Input coupling capacitors Used to block the DC component. Reducing the reactance value of these capacitors can reduce output noise, since output noise is exacerbated due to the 1/f noise signal source resistance dependencies if these capacitors have a large reactances at low frequencies. The impulse noise that occurs when power is first applied can be reduced by increasing the values of C1 and C11, and reducing the values of the NF side C3 and C13.
C2, C12	Input filter capacitors High band noise can be reduced by the filters formed by these capacitors and R1 and R11.
C3, C13	NF capacitors These capacitors determine the low band cutoff frequency. $f_L = \frac{1}{2\pi \times C3(13) \times R3(13)}$ Voltage gain can be acquired up to the low band by increasing the value of these capacitors. However, since this increases the impulse noise that occurs when power is applied, limit the values of these capacitors to what is actually required.
C4, C14	Oscillation prevention capacitors These capacitors increase stability at large outputs and high temperatures.
C5, C15	Oscillation prevention capacitors The use of Mylar capacitors with superlative temperature and frequency characteristics is recommended.
C6, C7	Oscillation prevention capacitors Insert these capacitors as close as possible to the IC power supply pins. They lower the power supply impedance and provide stable IC operation. Electrolytic capacitors are recommended.
C8, C9	Decoupling capacitors The time constant circuits formed in conjunction with R8 and R9 reduce the impulse noise that occurs when power is applied and remove ripple components that enter from the power supply line.
R1, R11	Input filter resistors.
R2, R12	Input bias resistors. These resistors bias the input pins to 0 V. The input impedance is largely determined by these resistors.
R3, R13, R4, R14	These resistors determine the voltage gain (VG). A voltage gain of 40 dBm, achieved by setting R3 and R13 to 560 Ω and R4 and R14 to 56 kΩ, is recommended. It is desirable that R3 and R13 be used to change the voltage gain. If R4 and R14 are used to change the voltage gain, set R4 = R2 and R14 = R12 for V <sub>N</sub> balance stability.
R5, R15	Oscillation prevention resistors
R6, R16	Oscillation prevention resistors The power dissipated by these resistors depends on the signal frequency as follows. $P_{R6(16)} = \left( \frac{V_{CC\ max}/\sqrt{2}}{1/2\pi f C5(15) + R6(16)} \right)^2 \times R6(16)$ Where f is the upper limit of the output signal frequency.
R7, R17	Output resistors These resistors increase the resistance to load shorting during high output.
R8, R9	Ripple filter resistors The P <sub>O</sub> max, ripple rejection, and impulse noise at power on are changed by these values. These resistors are the pre-drive transistor limit resistors in the load short state and the peak current when C8 and C9 are charged flows through these resistors. Therefore, the power dissipated in these resistors requires consideration when determining their values.
L1, L2	Oscillation prevention coils These inductors correct phase shifting due to capacitive loads and increase circuit stability.

# STK401-140

## Series Configuration

3-channel amplifiers type No.	Rated output	2-channel amplifiers type No.	Rated output	THD (%) f = 20 Hz to 20 kHz	Power supply voltage (V)			
					V <sub>CC</sub> max1	V <sub>CC</sub> max2	V <sub>CC</sub> 1	V <sub>CC</sub> 2
STK400-010	10 W × 3	STK401-010	10 W × 2	0.4	—	±26	±17.5	±14
STK400-020	15 W × 3	STK401-020	15 W × 2		—	±29	±20	±16
STK400-030	20 W × 3	STK401-030	20 W × 2		—	±34	±23	±19
STK400-040	25 W × 3	STK401-040	25 W × 2		—	±36	±25	±21
STK400-050	30 W × 3	STK401-050	30 W × 2		—	±39	±26	±22
STK400-060	35 W × 3	STK401-060	35 W × 2		—	±41	±28	±23
STK400-070	40 W × 3	STK401-070	40 W × 2		—	±44	±30	±24
STK400-080	45 W × 3	STK401-080	45 W × 2		—	±45	±31	±25
STK400-090	50 W × 3	STK401-090	50 W × 2		—	±47	±32	±26
STK400-100	60 W × 3	STK401-100	60 W × 2		—	±51	±35	±27
STK400-110	70 W × 3	STK401-110	70 W × 2		—	±56.0	—	±38
—	—	STK401-120	80 W × 2		—	±61.0	—	±42
—	—	STK401-130	100 W × 2		—	±65.0	—	±45
—	—	STK401-140	120 W × 2		—	±74.0	—	±51

Note: V<sub>CC</sub> max1 When R<sub>L</sub> = 6 Ω  
 V<sub>CC</sub> max2 When R<sub>L</sub> = between 3 and 6 Ω  
 V<sub>CC</sub>1 When R<sub>L</sub> = 6 Ω  
 V<sub>CC</sub>2 When R<sub>L</sub> = 3 Ω

## End Product Series Design Example Using the Same PCB

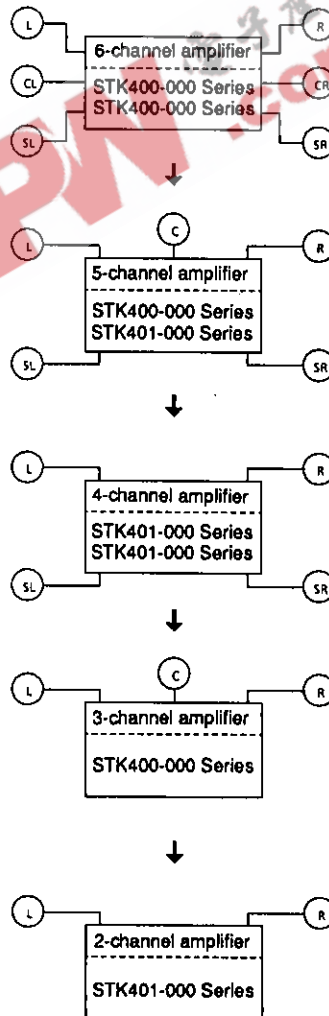

External Circuits

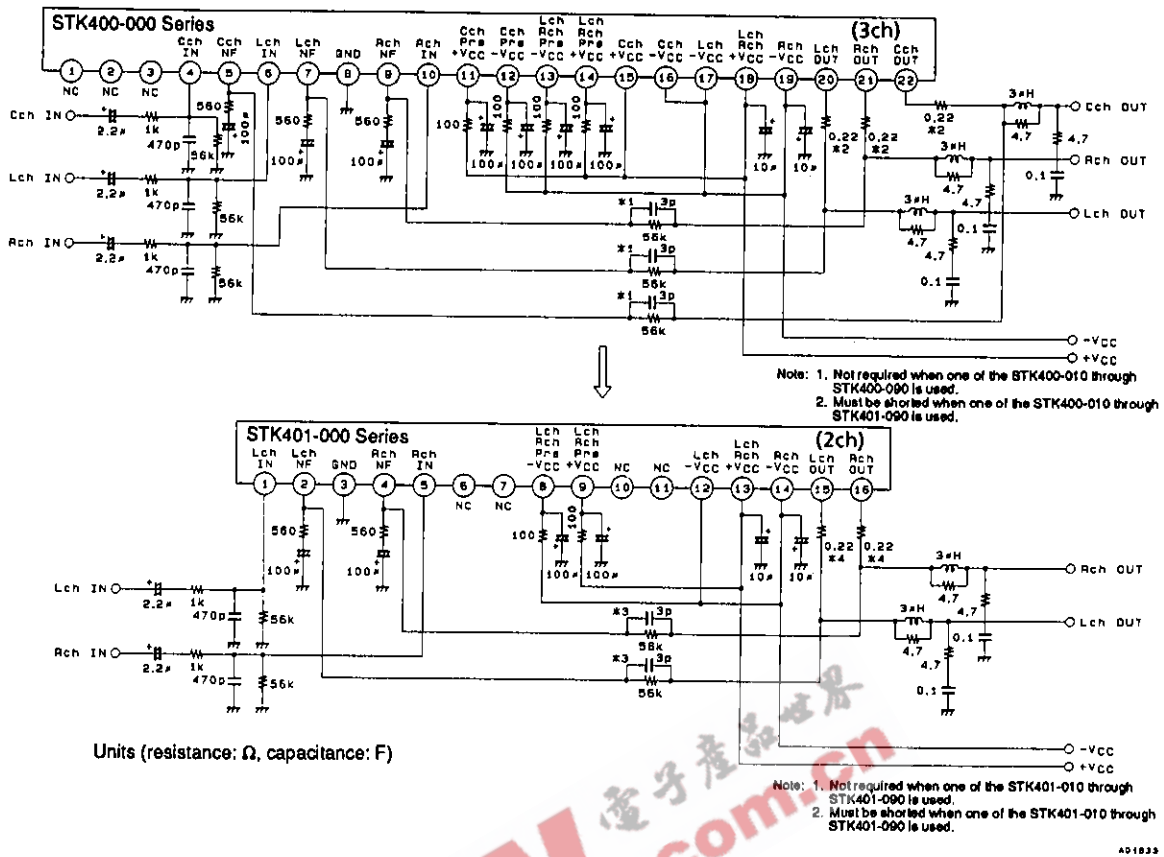

Thermal Design Example

The thermal resistance  $\theta_{c-a}$  of the required heat sink for a total case-internal power dissipation  $P_d$  for the STK401-140 can be derived as follows.

Condition 1: The IC case temperature  $T_c$  must not exceed 125°C.

$$P_d \times \theta_{c-a} + T_a < 125^\circ\text{C} \dots\dots\dots(1)$$

$T_a$ : Set guaranteed ambient temperature

Condition 2: The individual power transistor junction temperatures must not exceed 150°C.

$$P_d \times \theta_{c-a} + P_d/N \times \theta_{j-c} + T_a < 150^\circ\text{C} \dots\dots\dots(2)$$

N: Number of power transistors

$\theta_{j-c}$ : Thermal resistance per power transistor

However, the power dissipated by the power transistors ( $P_d$ ) is divided evenly among the N transistors.

Solving equations (1) and (2) for  $\theta_{c-a}$  gives:

$$\theta_{c-a} < (125 - T_a)/P_d \dots\dots\dots(1')$$

$$\theta_{c-a} < (150 - T_a)/P_d - \theta_{j-c}/N \dots\dots\dots(2')$$

A value that satisfies these two equations will be the required heat sink thermal resistance.

The required heat sink thermal resistance can be derived from formulas (1)' and (2)' once the following specifications have been determined.

- Power supply voltage  $V_{CC}$
- Load resistance  $R_L$
- Guaranteed ambient temperature  $T_a$

When the STK401-140  $V_{CC}$  is  $\pm 51$  V and  $R_L$  is 6 Ω, the case-internal total power dissipation for a continuous sine wave signal will have a maximum value of 177 W, as shown in Figure 1.

One tenth of the  $P_O$  max for this kind of continuous signal is generally used as an estimate of power dissipation for actual music signals, although this may vary somewhat depending on safety standards.

$$P_d = 107 \text{ W (when } 1/10 P_O \text{ max is } 12 \text{ W)}$$

The STK401-140 has four power transistors and the thermal resistance per transistor is  $1.0^{\circ}\text{C}/\text{W}$ . If the guaranteed ambient temperature  $T_a$  is  $50^{\circ}\text{C}$  then the required heat sink thermal resistance can be calculated as follows.

$$\begin{aligned} \text{From formula (1) } \theta_{c-a} &< (125 - 50)/107 \\ &< 0.70 \end{aligned}$$

$$\begin{aligned} \text{From formula (2) } \theta_{c-a} &< (150 - 50)/107 - 1.0/4 \\ &< 0.68 \end{aligned}$$

Therefore the value  $0.68^{\circ}\text{C}/\text{W}$ , which satisfies both of these formulas, is the required heat sink thermal resistance.

Note that this thermal design example assumes a rated power supply and the actual thermal design must be confirmed in the end product itself.

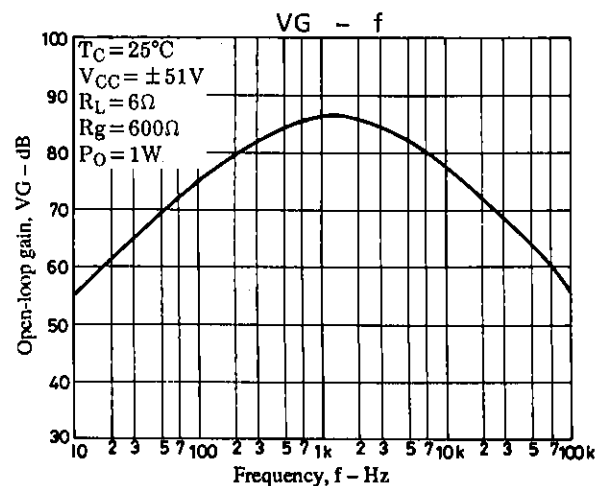
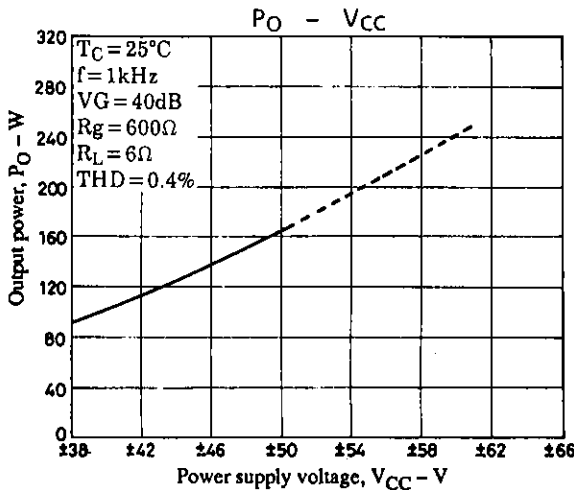
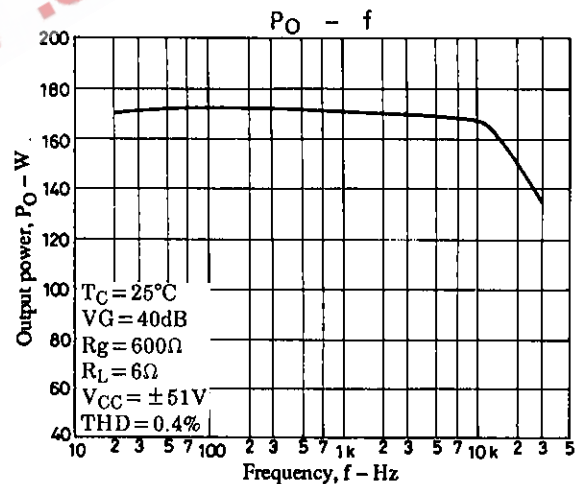
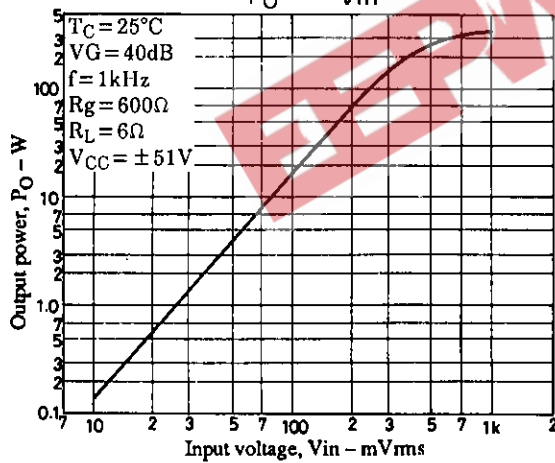
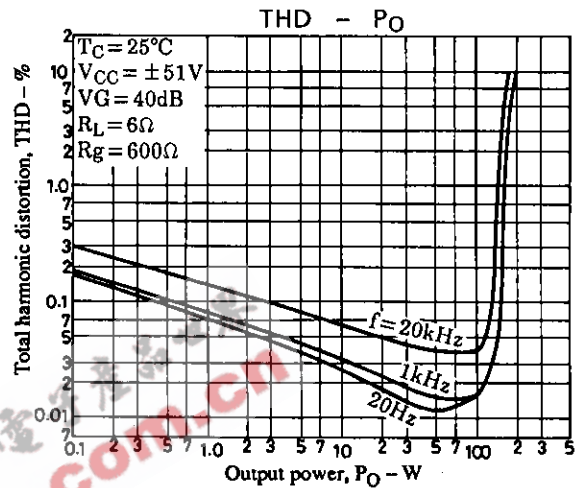
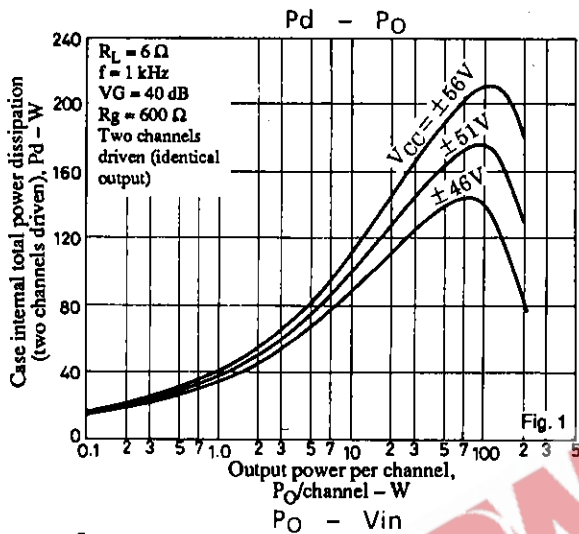

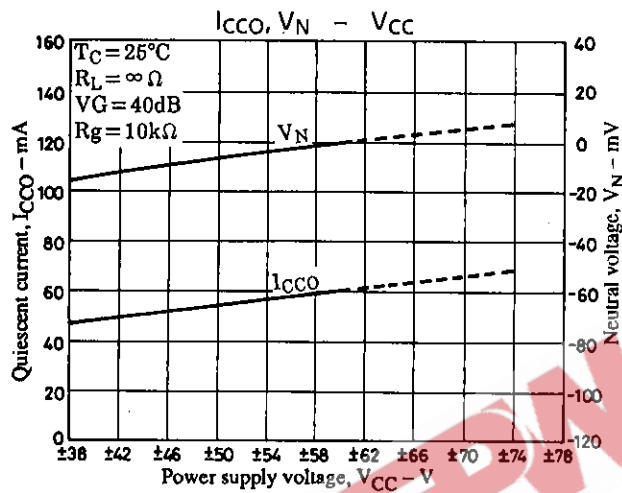
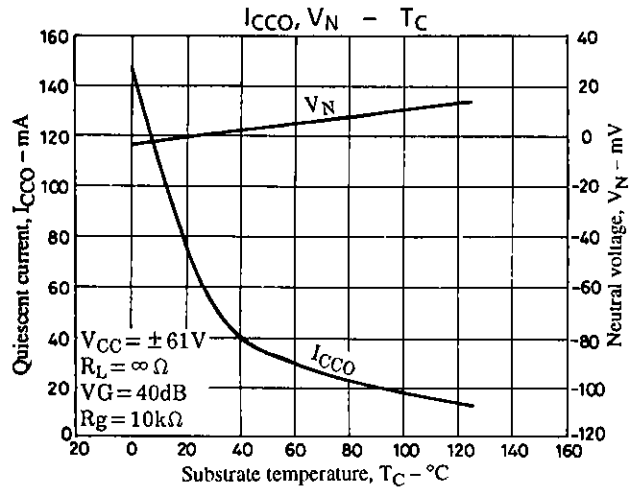
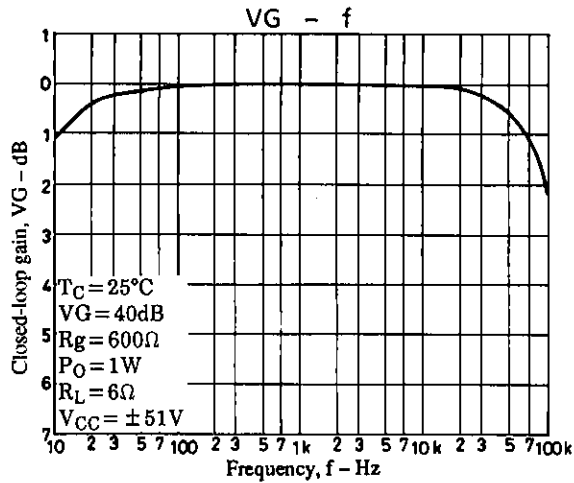

- No products described or contained herein are intended for use in surgical implants, life-support systems, aerospace equipment, nuclear power control systems, vehicles, disaster/crime-prevention equipment and the like, the failure of which may directly or indirectly cause injury, death or property loss.
- Anyone purchasing any products described or contained herein for an above-mentioned use shall:
  - ① Accept full responsibility and indemnify and defend SANYO ELECTRIC CO., LTD., its affiliates, subsidiaries and distributors and all their officers and employees, jointly and severally, against any and all claims and litigation and all damages, cost and expenses associated with such use;
  - ② Not impose any responsibility for any fault or negligence which may be cited in any such claim or litigation on SANYO ELECTRIC CO., LTD., its affiliates, subsidiaries and distributors or any of their officers and employees jointly or severally.
- Information (including circuit diagrams and circuit parameters) herein is for example only; it is not guaranteed for volume production. SANYO believes information herein is accurate and reliable, but no guarantees are made or implied regarding its use or any infringements of intellectual property rights or other rights of third parties.