

FEATURES

- V_{CC} Operation at 2.5 V and 3.3 V
- V_{IO} Accepts Signals up to 5.5 V
- 1.8-V Compatible Control-Pin Inputs
- Low-Power Mode When \overline{OE} Is Disabled (1 μ A)
- $r_{on} = 6 \Omega$ Max
- $\Delta r_{on} = 0.2 \Omega$ Typ
- $C_{io(on)} = 6$ pF Max
- Low Power Consumption (30 μ A Max)
- ESD > 2000-V Human-Body Model (HBM)
- High Bandwidth (1.1 GHz Typ)

APPLICATIONS

- Routes Signals for USB 1.0, 1.1, and 2.0

DESCRIPTION

The TS3USB221 is a high-bandwidth switch specially designed for the switching of high-speed USB 2.0 signals in handset and consumer applications, such as cell phones, digital cameras, and notebooks with hubs or controllers with limited USB I/Os. The wide bandwidth (1.1 GHz) of this switch allows signals to pass with minimum edge and phase distortion. The device multiplexes differential outputs from a USB host device to one of two corresponding outputs. The switch is bidirectional and offers little or no attenuation of the high-speed signals at the outputs. It is designed for low bit-to-bit skew and high channel-to-channel noise isolation, and is compatible with various standards, such as high-speed USB 2.0 (480 Mbps).

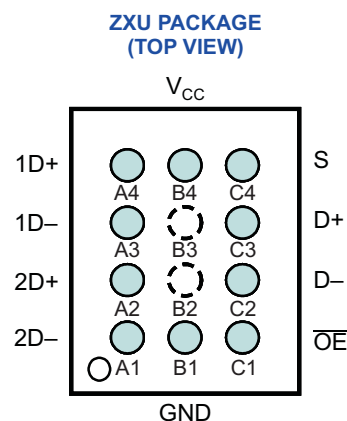
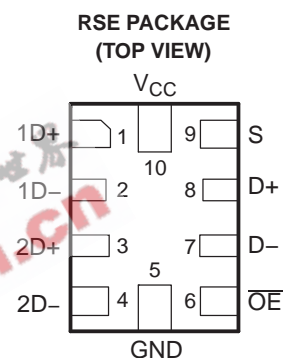
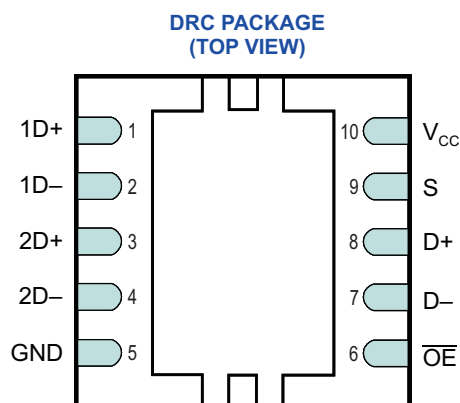

ORDERING INFORMATION

T_A	PACKAGE ⁽¹⁾		ORDERABLE PART NUMBER	TOP-SIDE MARKING
-40°C to 85°C	DRC	Reel of 3000	TS3USB221DRCR	ZWG
	RSE	Reel of 3000	TS3USB221RSER	Preview
	ZXU	Reel of 2500	TS3USB221ZXUR	Preview

(1) Package drawings, standard packing quantities, thermal data, symbolization, and PCB design guidelines are available at www.ti.com/sc/package.



Please be aware that an important notice concerning availability, standard warranty, and use in critical applications of Texas Instruments semiconductor products and disclaimers thereto appears at the end of this data sheet.

TS3USB221
HIGH-SPEED USB 2.0 (480-Mbps) 1:2 MULTIPLEXER/DEMULTIPLEXER SWITCH
WITH SINGLE ENABLE

SCDS220 – NOVEMBER 2006

PIN DESCRIPTION

NAME	DESCRIPTION
\overline{OE}	Bus-switch enable
S	Select input
D	Bus A
nD	Bus B

TRUTH TABLE

S	\overline{OE}	FUNCTION
X	H	Disconnect
L	L	D = 1D
H	L	D = 2D

BLOCK DIAGRAM

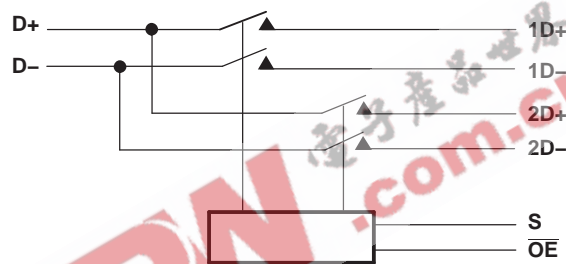

SIMPLIFIED SCHEMATIC, EACH FET SWITCH (SW)

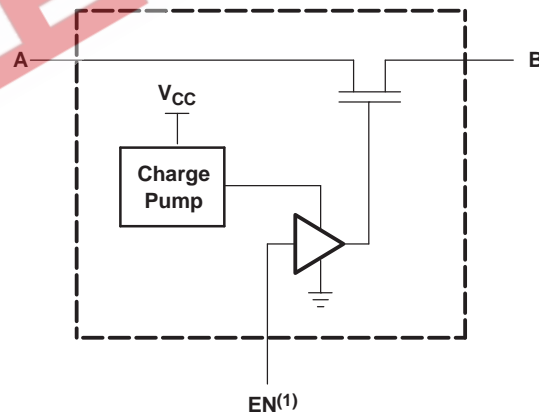

(1) EN is the internal enable signal applied to the switch.

Absolute Maximum Ratings⁽¹⁾

over operating free-air temperature range (unless otherwise noted)

		MIN	MAX	UNIT
V _{CC}	Supply voltage range	−0.5	4.6	V
V _{IN}	Control input voltage range ⁽²⁾⁽³⁾	−0.5	7	V
V _{I/O}	Switch I/O voltage range ⁽²⁾⁽³⁾⁽⁴⁾	−0.5	7	V
I _{IK}	Control input clamp current	V _{IN} < 0	−50	mA
I _{I/OK}	I/O port clamp current	V _{I/O} < 0	−50	mA
I _{I/O}	ON-state switch current ⁽⁵⁾		±64	mA
	Continuous current through V _{CC} or GND		±100	mA
θ _{JA}	Package thermal impedance ⁽⁶⁾	DRC package	48.7	°C/W
		RSE package	TBD	
		ZXU package	TBD	
T _{stg}	Storage temperature range	−65	150	°C

- (1) Stresses beyond those listed under "absolute maximum ratings" may cause permanent damage to the device. These are stress ratings only, and functional operation of the device at these or any other conditions beyond those indicated under "recommended operating conditions" is not implied. Exposure to absolute-maximum-rated conditions for extended periods may affect device reliability.
- (2) All voltages are with respect to ground, unless otherwise specified.
- (3) The input and output voltage ratings may be exceeded if the input and output clamp-current ratings are observed.
- (4) V_I and V_O are used to denote specific conditions for V_{I/O}.
- (5) I_I and I_O are used to denote specific conditions for I_{I/O}.
- (6) The package thermal impedance is calculated in accordance with JESD 51-7.

Recommended Operating Conditions⁽¹⁾

		MIN	MAX	UNIT
V _{CC}	Supply voltage	2.3	3.6	V
V _{IH}	High-level control input voltage	V _{CC} = 2.3 V to 2.7 V	0.46 × V _{CC}	V
		V _{CC} = 2.7 V to 3.6 V	0.46 × V _{CC}	
V _{IL}	Low-level control input voltage	V _{CC} = 2.3 V to 2.7 V	0.25 × V _{CC}	V
		V _{CC} = 2.7 V to 3.6 V	0.25 × V _{CC}	
V _{I/O}	Data input/output voltage	0	5.5	V
T _A	Operating free-air temperature	−40	85	°C

- (1) All unused control inputs of the device must be held at V_{CC} or GND to ensure proper device operation. Refer to the TI application report, *Implications of Slow or Floating CMOS Inputs*, literature number SCBA004.

TS3USB221

HIGH-SPEED USB 2.0 (480-Mbps) 1:2 MULTIPLEXER/DEMULTIPLEXER SWITCH WITH SINGLE ENABLE



SCDS220 – NOVEMBER 2006

Electrical Characteristics⁽¹⁾

over operating free-air temperature range (unless otherwise noted)

PARAMETER		TEST CONDITIONS		MIN	TYP ⁽²⁾	MAX	UNIT
V_{IK}		$V_{CC} = 3.6\text{ V}, 2.7\text{ V},$	$I_I = -18\text{ mA}$			-1.8	V
I_{IN}	Control inputs	$V_{CC} = 3.6\text{ V}, 2.7\text{ V},$	$V_{IN} = 0\text{ to }3.6\text{ V}$			± 1	μA
$I_{OZ}^{(3)}$		$V_{CC} = 3.6\text{ V}, 2.7\text{ V},$ $V_O = 0\text{ to }3.6\text{ V}, V_I = 0,$	Switch OFF, $V_{IN} = V_{CC}\text{ or GND}$			± 1	μA
I_{OFF}		$V_{CC} = 0\text{ V}$	$V_{I/O} = 0\text{ to }3.6\text{ V}$			± 2	μA
			$V_{I/O} = 0\text{ to }2.7\text{ V}$			± 1	
I_{CC}		$V_{CC} = 3.6\text{ V}, 2.7\text{ V},$ $V_{IN} = V_{CC}\text{ or GND},$	$I_{I/O} = 0,$ Switch ON or OFF,			30	μA
I_{CC} (low power mode)		$V_{CC} = 3.6\text{ V}, 2.7\text{ V},$ $V_{IN} = V_{CC}\text{ or GND}$	Switch disabled (\overline{OE} in high state)			1	μA
$\Delta I_{CC}^{(4)}$	Control inputs	$V_{CC} = 3.6\text{ V}$	One input at 1.8 V, Other inputs at V_{CC} or GND			20	μA
		$V_{CC} = 2.7\text{ V}$				0.5	
C_{in}	Control inputs	$V_{CC} = 3.3\text{ V}, 2.5\text{ V},$	$V_{IN} = 3.3\text{ V or }0$		1	2	pF
$C_{io(OFF)}$		$V_{CC} = 3.3\text{ V}, 2.5\text{ V},$ $V_{I/O} = 3.3\text{ V or }0$	Switch OFF, $V_{IN} = V_{CC}\text{ or GND}$		3	4	pF
$C_{io(ON)}$		$V_{CC} = 3.3\text{ V}, 2.5\text{ V},$ $V_{I/O} = 3.3\text{ V or }0$	Switch ON, $V_{IN} = V_{CC}\text{ or GND}$		5	6	pF
$r_{on}^{(5)}$		$V_{CC} = 3\text{ V}, 2.3\text{ V}$	$V_I = 0,$	$I_O = 30\text{ mA}$		6	Ω
			$V_I = 2.4\text{ V},$	$I_O = -15\text{ mA}$		6	
Δr_{on}		$V_{CC} = 3\text{ V}, 2.3\text{ V}$	$V_I = 0,$	$I_O = 30\text{ mA}$		0.2	Ω
			$V_I = 1.7,$	$I_O = -15\text{ mA}$		0.2	
$r_{on(Flat)}$		$V_{CC} = 3\text{ V}, 2.3\text{ V}$	$V_I = 0,$	$I_O = 30\text{ mA}$		1	Ω
			$V_I = 1.7,$	$I_O = -15\text{ mA}$		1	

(1) V_{IN} and I_{IN} refer to control inputs. V_I , V_O , I_I , and I_O refer to data pins.

(2) All typical values are at $V_{CC} = 3.3\text{ V}$ (unless otherwise noted), $T_A = 25^\circ\text{C}$.

(3) For I/O ports, the parameter I_{OZ} includes the input leakage current.

(4) This is the increase in supply current for each input that is at the specified TTL voltage level, rather than V_{CC} or GND.

(5) Measured by the voltage drop between the A and B terminals at the indicated current through the switch. ON-state resistance is determined by the lower of the voltages of the two (A or B) terminals.

Dynamic Electrical Characteristics

over operating range, $T_A = -40^\circ\text{C to }85^\circ\text{C}, V_{CC} = 3.3\text{ V} \pm 10\%, \text{GND} = 0\text{ V}$

PARAMETER		TEST CONDITIONS	MIN	TYP ⁽¹⁾	MAX	UNIT
X_{TALK}	Crosstalk	$R_L = 50\ \Omega, f = 250\text{ MHz}$		-40		dB
O_{IRR}	OFF isolation	$R_L = 50\ \Omega, f = 250\text{ MHz}$		-41		dB
BW	Bandwidth (-3 dB)	$R_L = 50\ \Omega$		1.1		GHz

(1) For Max or Min conditions, use the appropriate value specified under Electrical Characteristics for the applicable device type.

Dynamic Electrical Characteristics

over operating range, $T_A = -40^{\circ}\text{C}$ to 85°C , $V_{CC} = 2.5\text{ V} \pm 10\%$, $\text{GND} = 0\text{ V}$

PARAMETER		TEST CONDITIONS	MIN	TYP ⁽¹⁾	MAX	UNIT
X_{TALK}	Crosstalk	$R_L = 50\ \Omega$, $f = 250\text{ MHz}$		-39		dB
O_{IRR}	OFF isolation	$R_L = 50\ \Omega$, $f = 250\text{ MHz}$		-40		dB
BW	Bandwidth (-3 dB)	$R_L = 50\ \Omega$		1.1		GHz

(1) For Max or Min conditions, use the appropriate value specified under Electrical Characteristics for the applicable device type.

Switching Characteristics

over operating range, $T_A = -40^{\circ}\text{C}$ to 85°C , $V_{CC} = 3.3\text{ V} \pm 10\%$, $\text{GND} = 0\text{ V}$

PARAMETER		TEST CONDITIONS	MIN	TYP ⁽¹⁾	MAX	UNIT
t_{pd}	Propagation delay ⁽²⁾⁽³⁾			0.25		ns
t_{ON}	Line enable time,	SEL to D, nD			30	ns
t_{OFF}	Line disable time,	SEL to D, nD			12	ns
t_{ON}	Line enable time,	$\overline{\text{OE}}$ to D, nD			17	ns
t_{OFF}	Line disable time,	$\overline{\text{OE}}$ to D, nD			10	ns
$t_{\text{SK(O)}}$	Output skew between center port to any other port ⁽²⁾			0.1	0.2	ns
$t_{\text{SK(P)}}$	Skew between opposite transitions of the same output ($t_{\text{PHL}} - t_{\text{PLH}}$) ⁽²⁾			0.1	0.2	ns

(1) For Max or Min conditions, use the appropriate value specified under Electrical Characteristics for the applicable device type.

(2) Specified by design

(3) The bus switch contributes no propagational delay other than the RC delay of the on resistance of the switch and the load capacitance. The time constant for the switch alone is of the order of 0.25 ns for 10-pF load. Since this time constant is much smaller than the rise/fall times of typical driving signals, it adds very little propagational delay to the system. Propagational delay of the bus switch, when used in a system, is determined by the driving circuit on the driving side of the switch and its interactions with the load on the driven side.

Switching Characteristics

over operating range, $T_A = -40^{\circ}\text{C}$ to 85°C , $V_{CC} = 2.5\text{ V} \pm 10\%$, $\text{GND} = 0\text{ V}$

PARAMETER		TEST CONDITIONS	MIN	TYP ⁽¹⁾	MAX	UNIT
t_{pd}	Propagation delay ⁽²⁾⁽³⁾			0.25		ns
t_{ON}	Line enable time	SEL to D, nD			50	ns
t_{OFF}	Line disable time	SEL to D, nD			23	ns
t_{ON}	Line enable time	$\overline{\text{OE}}$ to D, nD			32	ns
t_{OFF}	Line disable time	$\overline{\text{OE}}$ to D, nD			12	ns
$t_{\text{SK(O)}}$	Output skew between center port to any other port ⁽²⁾			0.1	0.2	ns
$t_{\text{SK(P)}}$	Skew between opposite transitions of the same output ($t_{\text{PHL}} - t_{\text{PLH}}$) ⁽²⁾			0.1	0.2	ns

(1) For Max or Min conditions, use the appropriate value specified under Electrical Characteristics for the applicable device type.

(2) Specified by design

(3) The bus switch contributes no propagational delay other than the RC delay of the on resistance of the switch and the load capacitance. The time constant for the switch alone is of the order of 0.25 ns for 10-pF load. Since this time constant is much smaller than the rise/fall times of typical driving signals, it adds very little propagational delay to the system. Propagational delay of the bus switch, when used in a system, is determined by the driving circuit on the driving side of the switch and its interactions with the load on the driven side.

APPLICATION INFORMATION

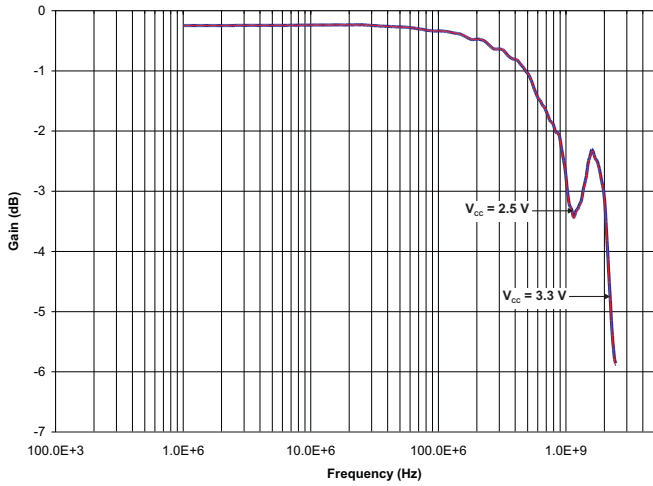

Figure 1. Gain vs Frequency

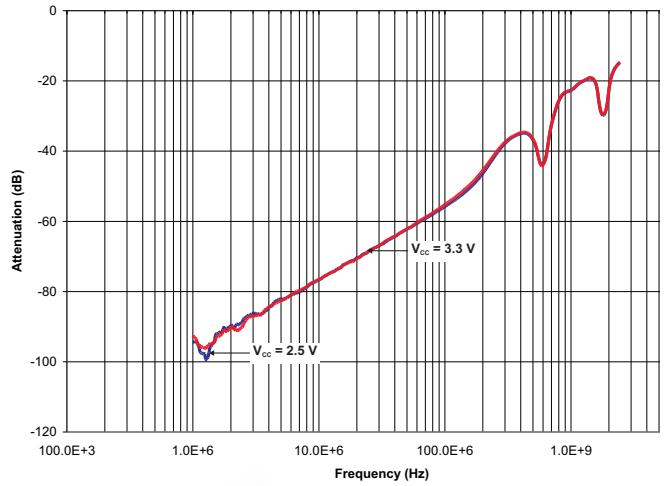

Figure 2. OFF Isolation vs Frequency

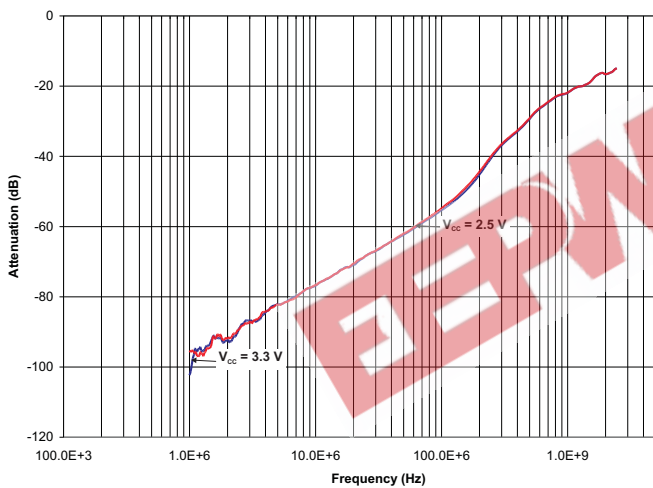

Figure 3. Crosstalk vs Frequency

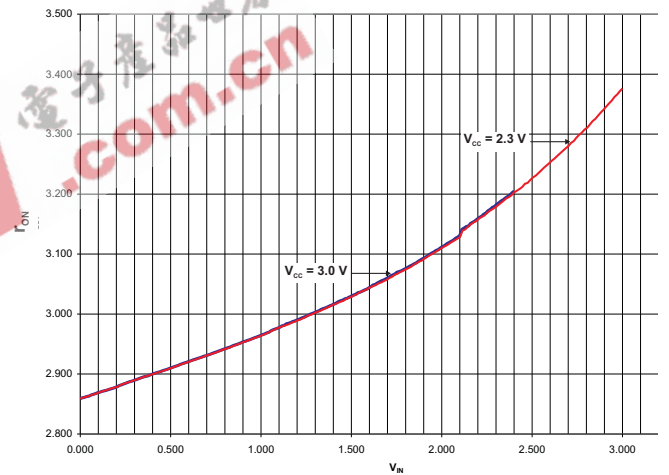

Figure 4. r_{ON} ($I_{OUT} = -15$ mA)

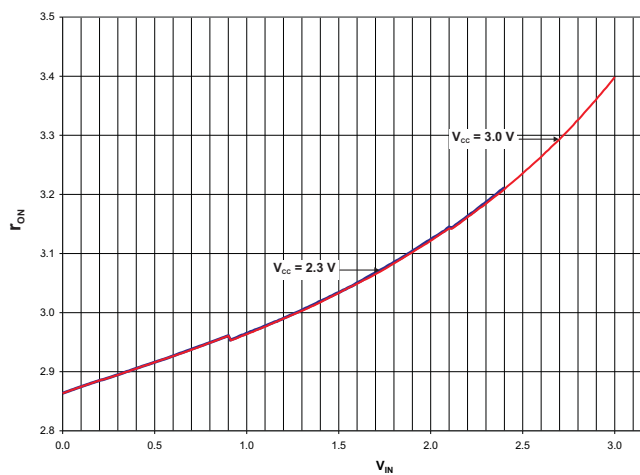
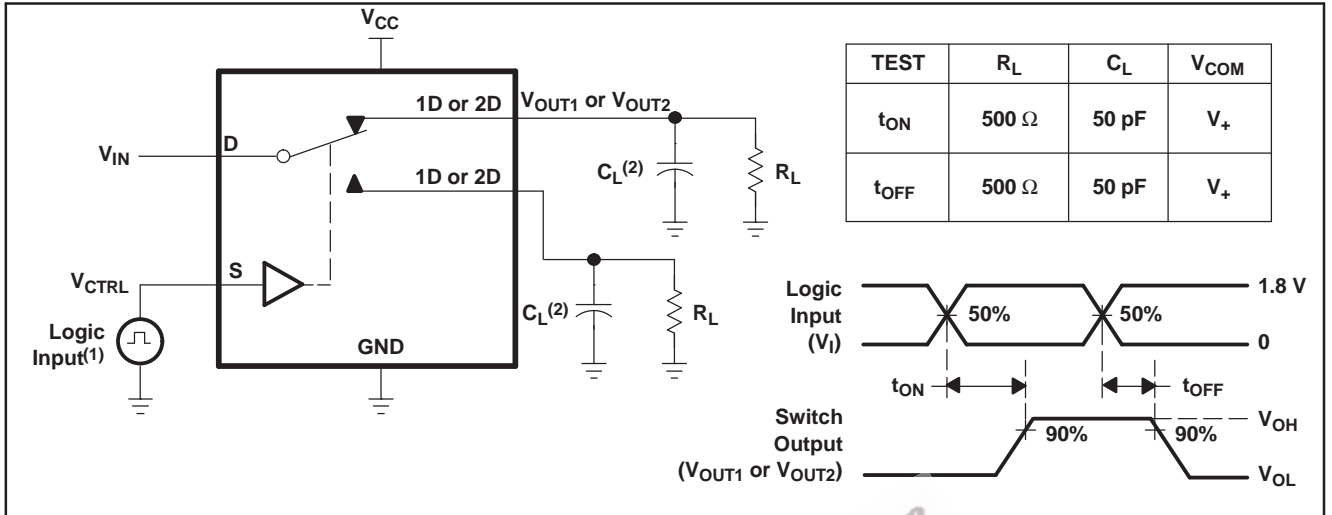

Figure 5. r_{ON} ($I_{OUT} = -30$ mA)

PARAMETER MEASUREMENT INFORMATION



- (1) All input pulses are supplied by generators having the following characteristics: PRR \leq 10 MHz, $Z_O = 50 \Omega$, $t_r < 5$ ns, $t_f < 5$ ns.
- (2) C_L includes probe and jig capacitance.

Figure 6. Turn-On (t_{ON}) and Turn-Off Time (t_{OFF})

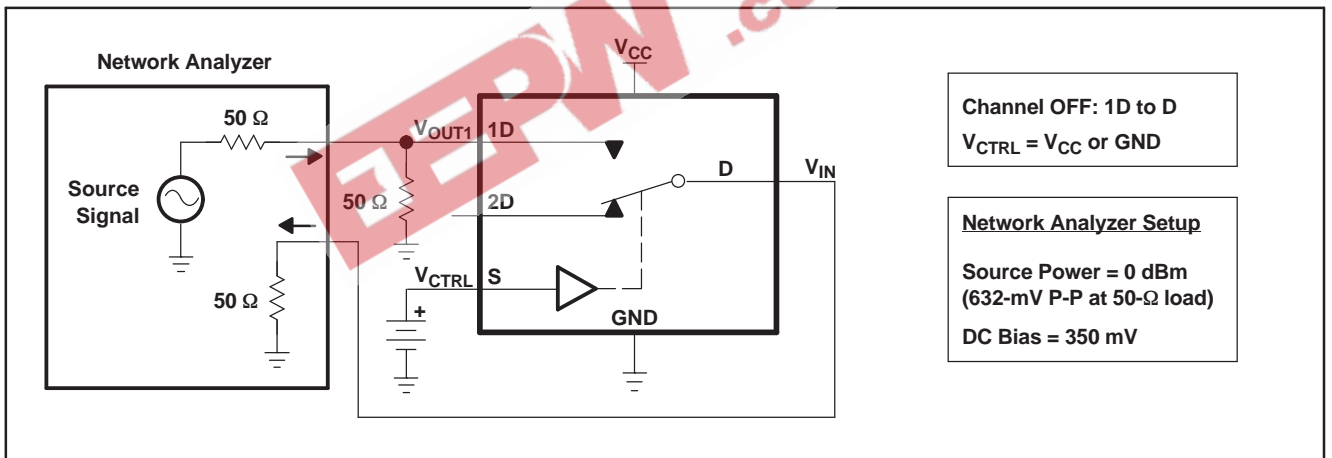

Figure 7. OFF Isolation (O_{ISO})

PARAMETER MEASUREMENT INFORMATION (continued)

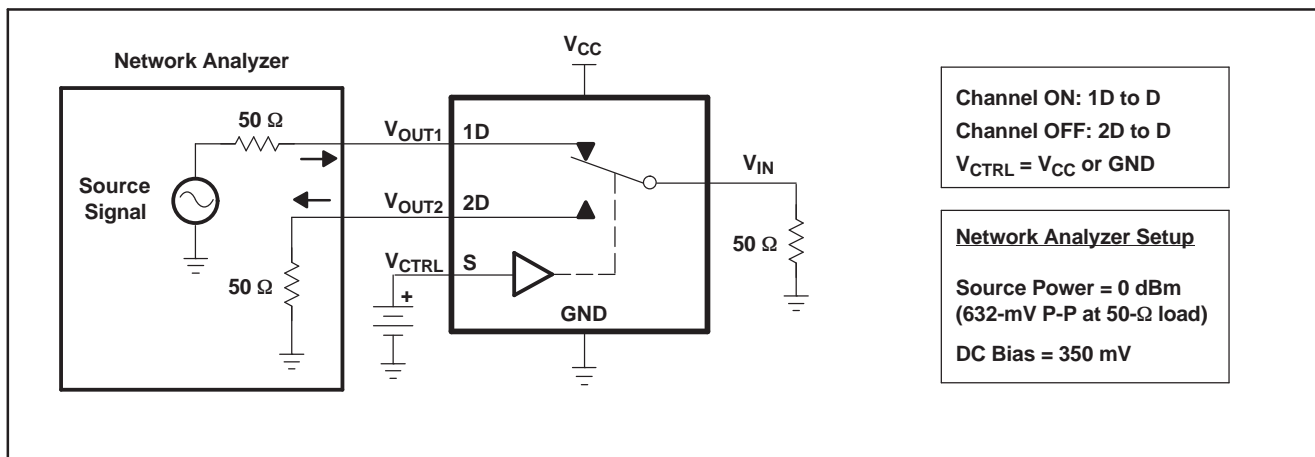

Figure 8. Crosstalk (X_{TALK})

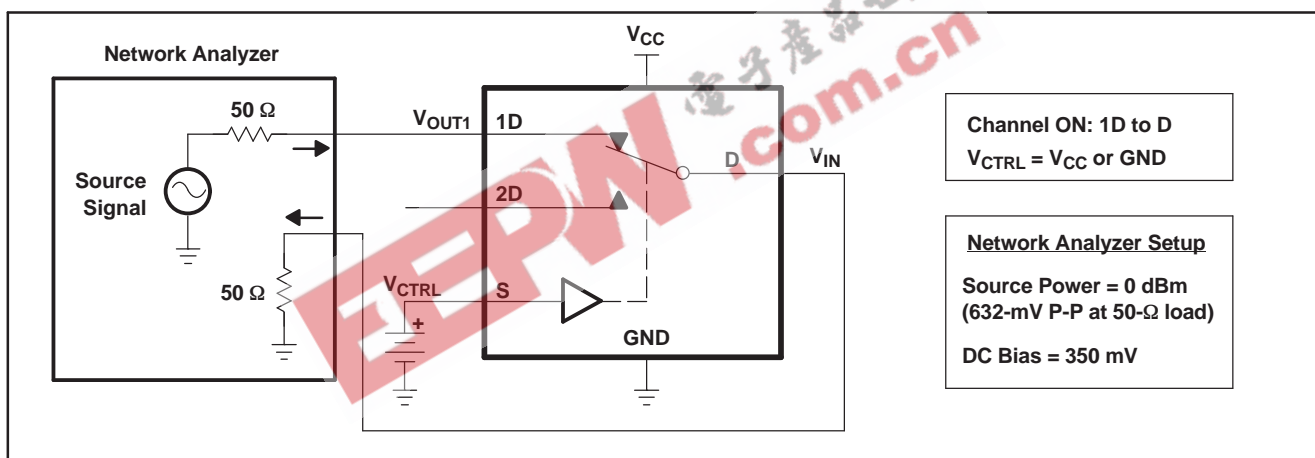

Figure 9. Bandwidth (BW)

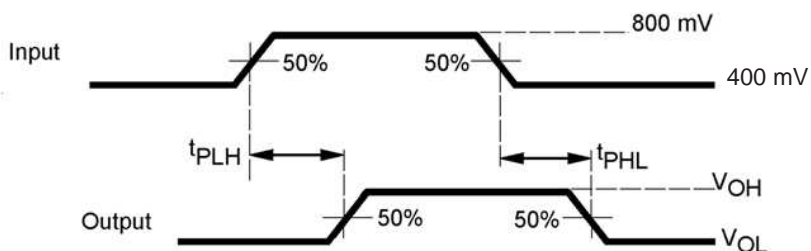

Figure 10. Propagation Delay

PARAMETER MEASUREMENT INFORMATION (continued)

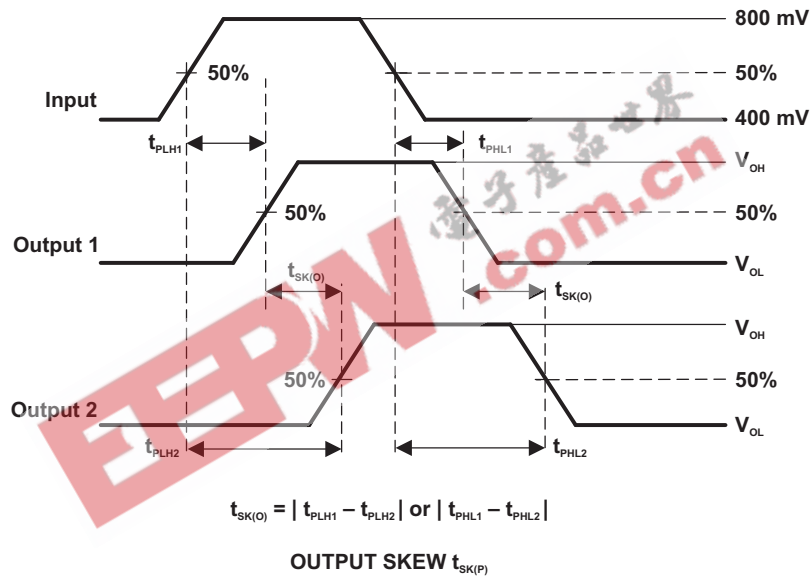
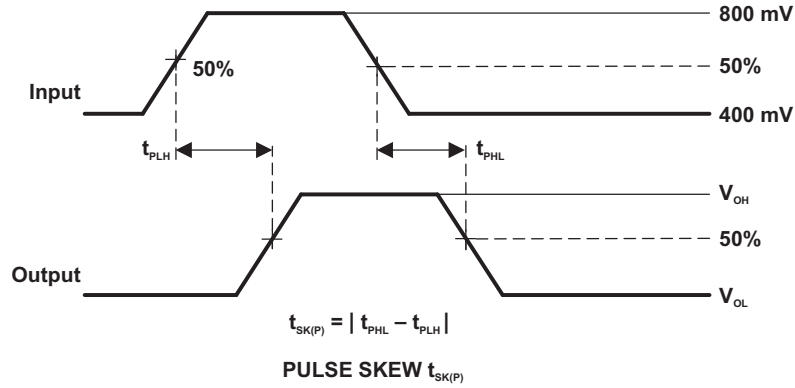

Figure 11. Skew Test

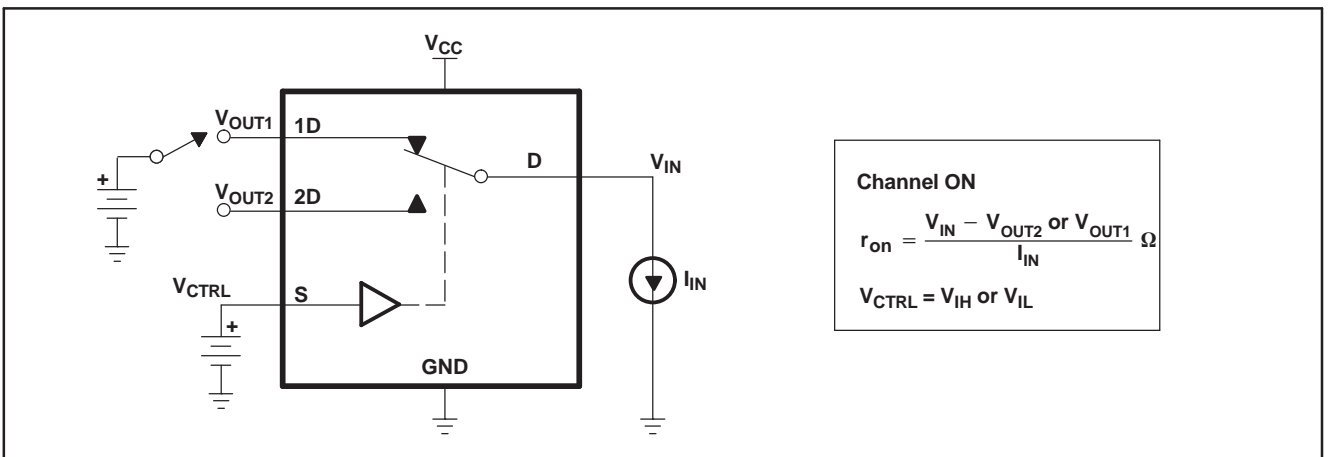

Figure 12. ON-State Resistance (r_{on})

PARAMETER MEASUREMENT INFORMATION (continued)

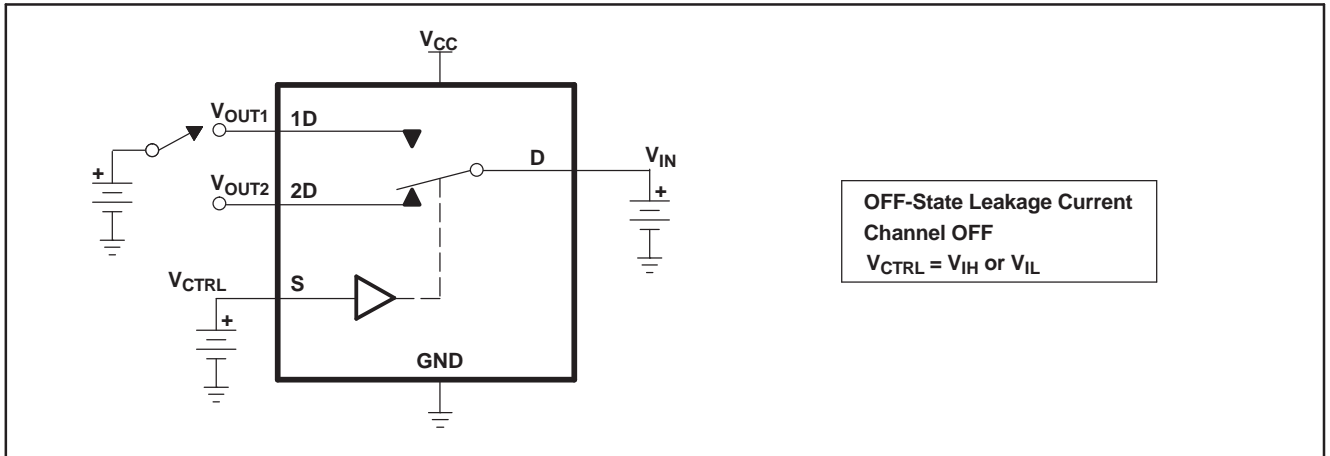

Figure 13. OFF-State Leakage Current

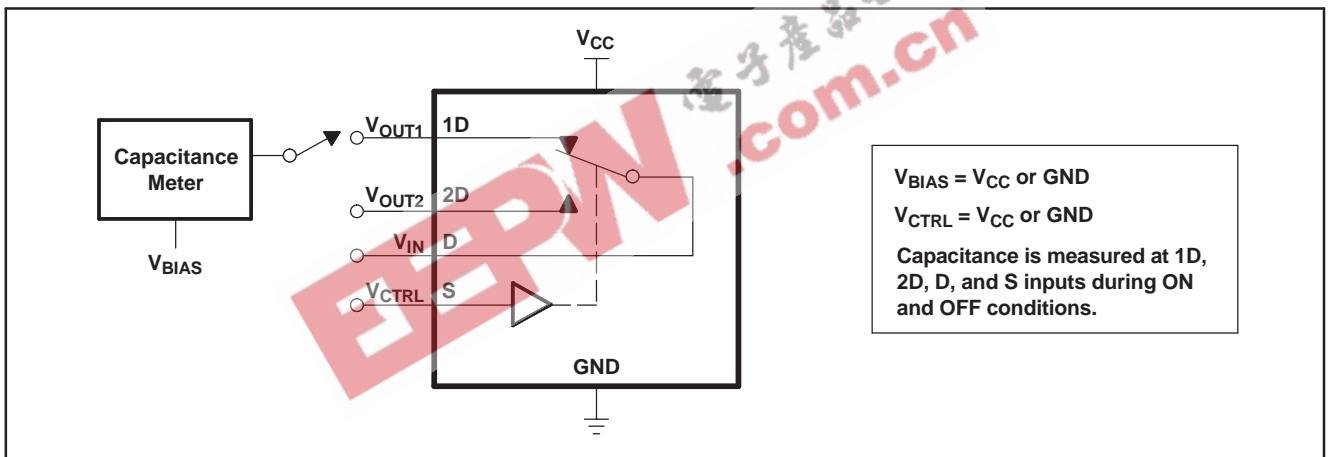

Figure 14. Capacitance

PACKAGING INFORMATION

Orderable Device	Status ⁽¹⁾	Package Type	Package Drawing	Pins	Package Qty	Eco Plan ⁽²⁾	Lead/Ball Finish	MSL Peak Temp ⁽³⁾
TS3USB221DRCR	ACTIVE	SON	DRC	10	3000	Green (RoHS & no Sb/Br)	CU NIPDAU	Level-2-260C-1YEAR
TS3USB221RSER	ACTIVE	QFN	RSE	10	3000	Green (RoHS & no Sb/Br)	CU NIPDAU	Level-1-260C-UNLIM

⁽¹⁾ The marketing status values are defined as follows:

ACTIVE: Product device recommended for new designs.

LIFEBUY: TI has announced that the device will be discontinued, and a lifetime-buy period is in effect.

NRND: Not recommended for new designs. Device is in production to support existing customers, but TI does not recommend using this part in a new design.

PREVIEW: Device has been announced but is not in production. Samples may or may not be available.

OBSOLETE: TI has discontinued the production of the device.

⁽²⁾ Eco Plan - The planned eco-friendly classification: Pb-Free (RoHS), Pb-Free (RoHS Exempt), or Green (RoHS & no Sb/Br) - please check <http://www.ti.com/productcontent> for the latest availability information and additional product content details.

TBD: The Pb-Free/Green conversion plan has not been defined.

Pb-Free (RoHS): TI's terms "Lead-Free" or "Pb-Free" mean semiconductor products that are compatible with the current RoHS requirements for all 6 substances, including the requirement that lead not exceed 0.1% by weight in homogeneous materials. Where designed to be soldered at high temperatures, TI Pb-Free products are suitable for use in specified lead-free processes.

Pb-Free (RoHS Exempt): This component has a RoHS exemption for either 1) lead-based flip-chip solder bumps used between the die and package, or 2) lead-based die adhesive used between the die and leadframe. The component is otherwise considered Pb-Free (RoHS compatible) as defined above.

Green (RoHS & no Sb/Br): TI defines "Green" to mean Pb-Free (RoHS compatible), and free of Bromine (Br) and Antimony (Sb) based flame retardants (Br or Sb do not exceed 0.1% by weight in homogeneous material)

⁽³⁾ MSL, Peak Temp. -- The Moisture Sensitivity Level rating according to the JEDEC industry standard classifications, and peak solder temperature.

Important Information and Disclaimer: The information provided on this page represents TI's knowledge and belief as of the date that it is provided. TI bases its knowledge and belief on information provided by third parties, and makes no representation or warranty as to the accuracy of such information. Efforts are underway to better integrate information from third parties. TI has taken and continues to take reasonable steps to provide representative and accurate information but may not have conducted destructive testing or chemical analysis on incoming materials and chemicals. TI and TI suppliers consider certain information to be proprietary, and thus CAS numbers and other limited information may not be available for release.

In no event shall TI's liability arising out of such information exceed the total purchase price of the TI part(s) at issue in this document sold by TI to Customer on an annual basis.

MECHANICAL DATA

DRC (S-PDSO-N10)

PLASTIC SMALL OUTLINE

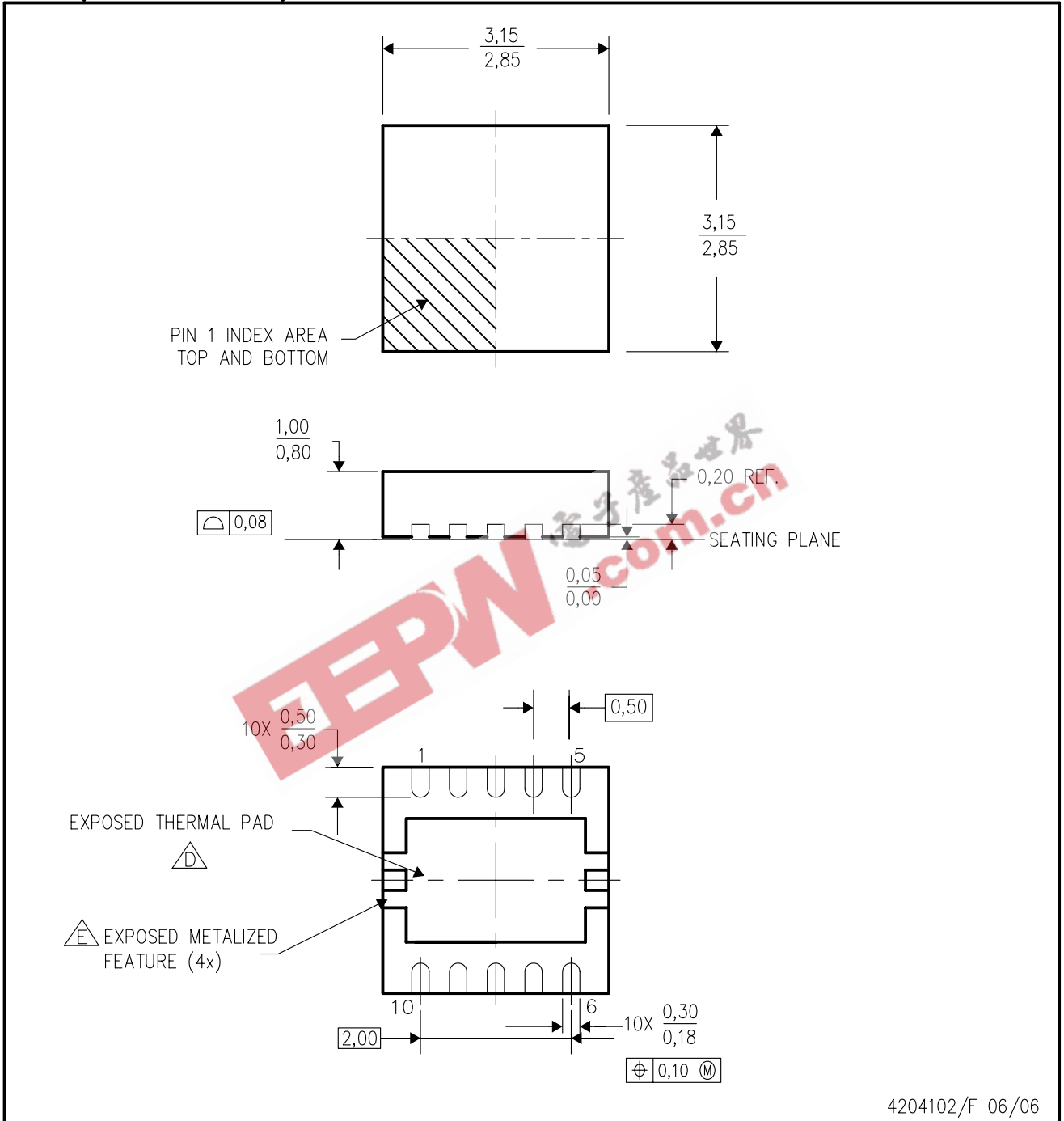

- NOTES:
- A. All linear dimensions are in millimeters. Dimensioning and tolerancing per ASME Y14.5M-1994.
 - B. This drawing is subject to change without notice.
 - C. Small Outline No-Lead (SON) package configuration.
 - D. The package thermal pad must be soldered to the board for thermal and mechanical performance. See the Product Data Sheet for details regarding the exposed thermal pad dimensions.
 - E. Metalized features are supplier options and may not be on the package.

MECHANICAL DATA

RSE (R-PQFP-N10)

PLASTIC QUAD FLATPACK

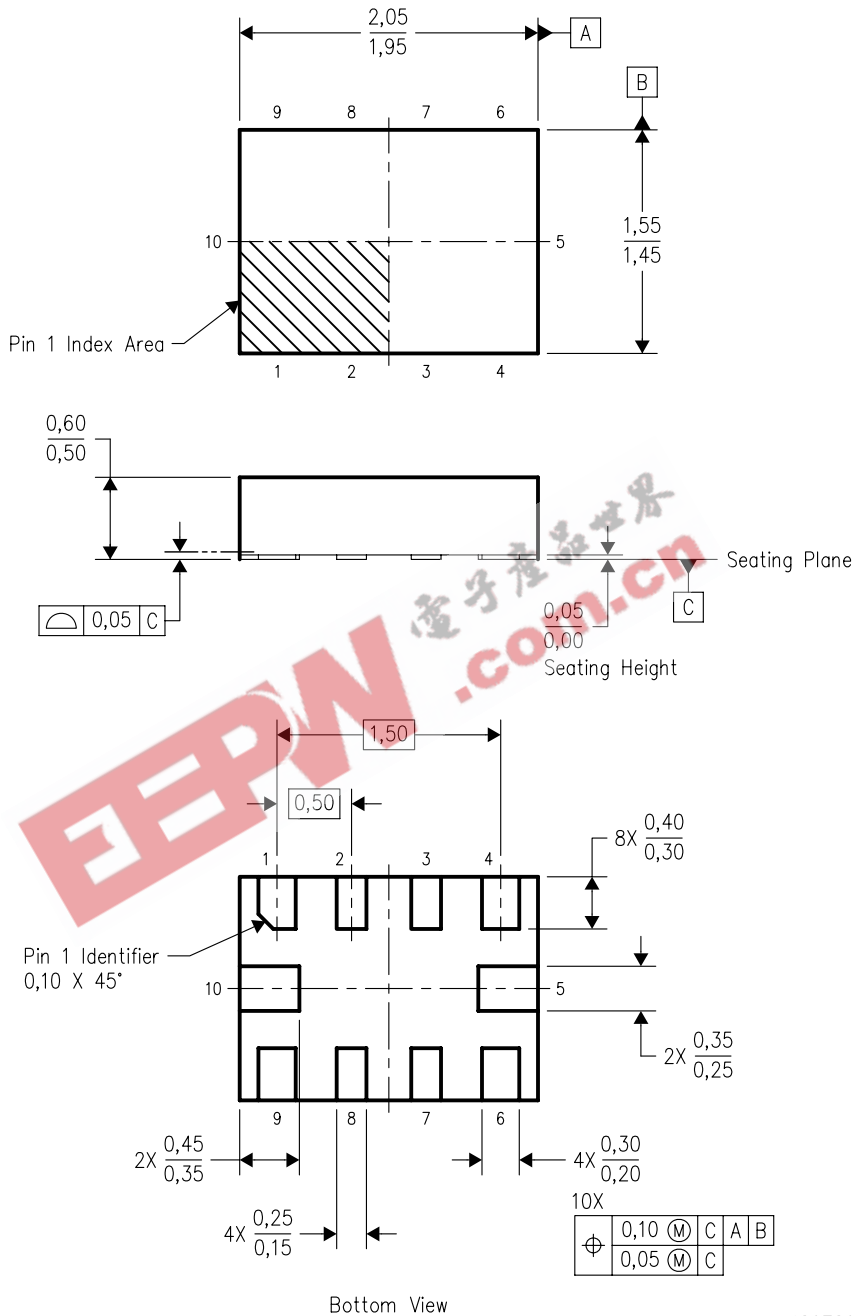

4207268-3/B 07/2006

NOTES: A. All linear dimensions are in millimeters. Dimensioning and tolerancing per ASME Y14.5M-1994.
 B. This drawing is subject to change without notice.

IMPORTANT NOTICE

Texas Instruments Incorporated and its subsidiaries (TI) reserve the right to make corrections, modifications, enhancements, improvements, and other changes to its products and services at any time and to discontinue any product or service without notice. Customers should obtain the latest relevant information before placing orders and should verify that such information is current and complete. All products are sold subject to TI's terms and conditions of sale supplied at the time of order acknowledgment.

TI warrants performance of its hardware products to the specifications applicable at the time of sale in accordance with TI's standard warranty. Testing and other quality control techniques are used to the extent TI deems necessary to support this warranty. Except where mandated by government requirements, testing of all parameters of each product is not necessarily performed.

TI assumes no liability for applications assistance or customer product design. Customers are responsible for their products and applications using TI components. To minimize the risks associated with customer products and applications, customers should provide adequate design and operating safeguards.

TI does not warrant or represent that any license, either express or implied, is granted under any TI patent right, copyright, mask work right, or other TI intellectual property right relating to any combination, machine, or process in which TI products or services are used. Information published by TI regarding third-party products or services does not constitute a license from TI to use such products or services or a warranty or endorsement thereof. Use of such information may require a license from a third party under the patents or other intellectual property of the third party, or a license from TI under the patents or other intellectual property of TI.

Reproduction of information in TI data books or data sheets is permissible only if reproduction is without alteration and is accompanied by all associated warranties, conditions, limitations, and notices. Reproduction of this information with alteration is an unfair and deceptive business practice. TI is not responsible or liable for such altered documentation.

Resale of TI products or services with statements different from or beyond the parameters stated by TI for that product or service voids all express and any implied warranties for the associated TI product or service and is an unfair and deceptive business practice. TI is not responsible or liable for any such statements.

Following are URLs where you can obtain information on other Texas Instruments products and application solutions:

Products		Applications	
Amplifiers	amplifier.ti.com	Audio	www.ti.com/audio
Data Converters	dataconverter.ti.com	Automotive	www.ti.com/automotive
DSP	dsp.ti.com	Broadband	www.ti.com/broadband
Interface	interface.ti.com	Digital Control	www.ti.com/digitalcontrol
Logic	logic.ti.com	Military	www.ti.com/military
Power Mgmt	power.ti.com	Optical Networking	www.ti.com/opticalnetwork
Microcontrollers	microcontroller.ti.com	Security	www.ti.com/security
Low Power Wireless	www.ti.com/lpw	Telephony	www.ti.com/telephony
		Video & Imaging	www.ti.com/video
		Wireless	www.ti.com/wireless

Mailing Address: Texas Instruments
Post Office Box 655303 Dallas, Texas 75265