

ESD PROTECTED, HIGH-SPEED USB 2.0 (480-Mbps) 1:2 MULTIPLEXER/DEMULTIPLEXER SWITCH WITH SINGLE ENABLE

FEATURES

- V_{CC} Operation at 2.5 V to 3.3 V
- $V_{I/O}$ Accepts Signals Up to 5.5 V
- 1.8-V Compatible Control-Pin Inputs
- Low-Power Mode When \overline{OE} Is Disabled (1 μ A)
- $r_{ON} = 6 \Omega$ Maximum
- $\Delta r_{ON} = 0.2 \Omega$ Typical
- $C_{io(on)} = 6$ pF Typical
- Low Power Consumption (30 μ A Maximum)
- High Bandwidth (900 MHz Typical)
- Latch-Up Performance Exceeds 100 mA Per JESD 78, Class II
- ESD Performance Tested Per JESD 22
 - 7000-V Human-Body Model (A114-B, Class II)
 - 1000-V Charged-Device Model (C101)
- ESD Performance I/O to GND
 - 12-kV Human-Body Model

APPLICATIONS

- Routes Signals for USB 1.0, 1.1, and 2.0

DESCRIPTION

The TS3USB221A is a high-bandwidth switch specially designed for the switching of high-speed USB 2.0 signals in handset and consumer applications, such as cell phones, digital cameras, and notebooks with hubs or controllers with limited USB I/Os. The wide bandwidth (900 MHz) of this switch allows signals to pass with minimum edge and phase distortion. The device multiplexes differential outputs from a USB host device to one of two corresponding outputs. The switch is bidirectional and offers little or no attenuation of the high-speed signals at the outputs. It is designed for low bit-to-bit skew and high channel-to-channel noise isolation, and is compatible with various standards, such as high-speed USB 2.0 (480 Mbps).

The TS3USB221A integrates ESD protection cells on all pins, is available in a tiny μ QFN package (2.0 mm \times 1.5 mm) and is characterized over the free air temperature range from -40°C to 85°C .

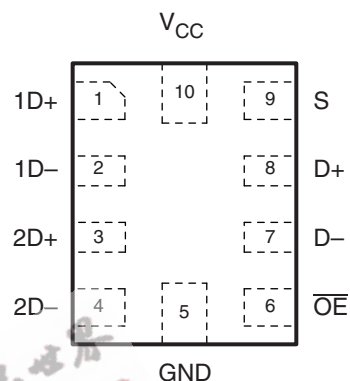
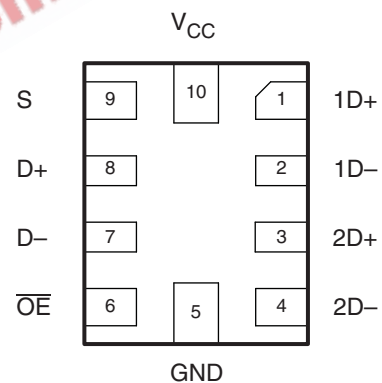
**RSE PACKAGE
(TOP VIEW)**

**RSE PACKAGE
(BOTTOM VIEW)**

Please be aware that an important notice concerning availability, standard warranty, and use in critical applications of Texas Instruments semiconductor products and disclaimers thereto appears at the end of this data sheet.

ORDERING INFORMATION

T _A	PACKAGE ⁽¹⁾⁽²⁾		ORDERABLE PART NUMBER	TOP-SIDE MARKING
-40°C to 85°C	QFN – RSE	Reel of 3000	TS3USB221ARSER	LHR

- (1) Package drawings, thermal data, and symbolization are available at www.ti.com/packaging.
- (2) For the most current package and ordering information, see the Package Option Addendum at the end of this document, or see the TI website at www.ti.com.

PIN DESCRIPTION

NAME	DESCRIPTION
\overline{OE}	Bus-switch enable
S	Select input
D	Bus A
nD	Bus B

TRUTH TABLE

S	\overline{OE}	FUNCTION
X	H	Disconnect
L	L	D = 1D
H	L	D = 2D

BLOCK DIAGRAM

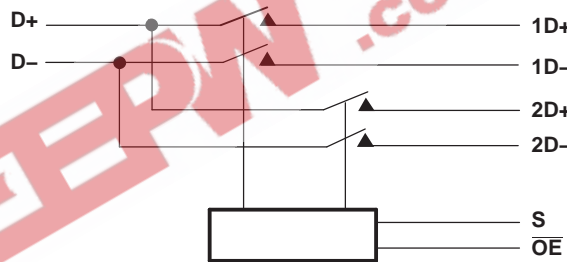

SIMPLIFIED SCHEMATIC, EACH FET SWITCH (SW)

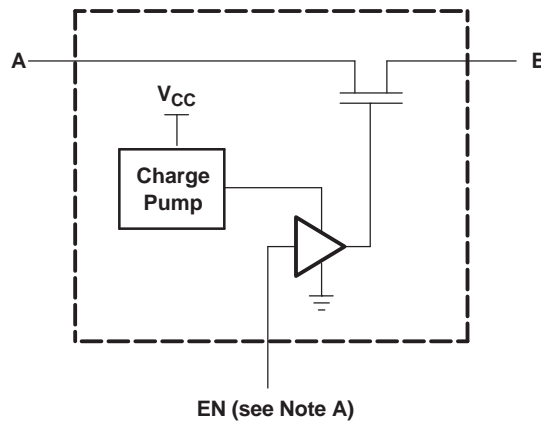

A. EN is the internal enable signal applied to the switch.

ABSOLUTE MAXIMUM RATINGS⁽¹⁾

over operating free-air temperature range (unless otherwise noted)

			MIN	MAX	UNIT
V_{CC}	Supply voltage range		-0.5	4.6	V
V_{IN}	Control input voltage range ⁽²⁾⁽³⁾		-0.5	7	V
$V_{I/O}$	Switch I/O voltage range ⁽²⁾⁽³⁾⁽⁴⁾		-0.5	7	V
I_{IK}	Control input clamp current	$V_{IN} < 0$		-50	mA
$I_{I/OK}$	I/O port clamp current	$V_{I/O} < 0$		-50	mA
$I_{I/O}$	ON-state switch current ⁽⁵⁾			±120	mA
	Continuous current through V_{CC} or GND			±100	mA
T_{stg}	Storage temperature range		-65	150	°C

(1) Stresses beyond those listed under "absolute maximum ratings" may cause permanent damage to the device. These are stress ratings only, and functional operation of the device at these or any other conditions beyond those indicated under "recommended operating conditions" is not implied. Exposure to absolute-maximum-rated conditions for extended periods may affect device reliability.

(2) All voltages are with respect to ground, unless otherwise specified.

(3) The input and output voltage ratings may be exceeded if the input and output clamp-current ratings are observed.

(4) V_I and V_O are used to denote specific conditions for $V_{I/O}$.

(5) I_I and I_O are used to denote specific conditions for $I_{I/O}$.

PACKAGE THERMAL IMPEDANCE

over operating free-air temperature range (unless otherwise noted)

			UNIT
θ_{JA}	Package thermal impedance ⁽¹⁾	RSE package	243 °C/W

(1) The package thermal impedance is calculated in accordance with JESD 51-7.

RECOMMENDED OPERATING CONDITIONS

			MIN	MAX	UNIT
V_{CC}	Supply voltage		2.3	3.6	V
V_{IH}	High-level control input voltage	$V_{CC} = 2.3 \text{ V to } 2.7 \text{ V}$	$0.46 \times V_{CC}$		V
		$V_{CC} = 2.7 \text{ V to } 3.6 \text{ V}$	$0.46 \times V_{CC}$		
V_{IL}	Low-level control input voltage	$V_{CC} = 2.3 \text{ V to } 2.7 \text{ V}$		$0.25 \times V_{CC}$	V
		$V_{CC} = 2.7 \text{ V to } 3.6 \text{ V}$		$0.25 \times V_{CC}$	
$V_{I/O}$	Data input/output voltage		0	5.5	V
T_A	Operating free-air temperature		-40	85	°C

ELECTRICAL CHARACTERISTICS⁽¹⁾

over operating free-air temperature range (unless otherwise noted)

PARAMETER		TEST CONDITIONS		MIN	TYP ⁽²⁾	MAX	UNIT
V _{IK}		V _{CC} = 3.6 V, 2.7 V,	I _I = -18 mA			-1.8	V
I _{IN}	Control inputs	V _{CC} = 3.6 V, 2.7 V, 0 V,	V _{IN} = 0 V to 3.6 V			±1	μA
I _{OZ} ⁽³⁾		V _{CC} = 3.6 V, 2.7 V, V _O = 0 V to 5.25 V, V _I = 0 V,	V _{IN} = V _{CC} or GND, Switch OFF			±1	μA
I _(OFF)		V _{CC} = 0 V		V _{I/O} = 0 V to 5.25 V		±2	μA
				V _{I/O} = 0 V to 3.6 V		±2	
				V _{I/O} = 0 V to 2.7 V		±1	
I _{CC}		V _{CC} = 3.6 V, 2.7 V, V _{IN} = V _{CC} or GND,	I _{I/O} = 0 V, Switch ON or OFF			30	μA
I _{CC} (low power mode)		V _{CC} = 3.6 V, 2.7 V, V _{IN} = V _{CC} or GND,	Switch disabled, OE in high state			1	μA
ΔI _{CC} ⁽⁴⁾	Control inputs	One input at 1.8 V, Other inputs at V _{CC} or GND		V _{CC} = 3.6 V		20	μA
				V _{CC} = 2.7 V		0.5	
C _{in}	Control inputs	V _{CC} = 3.3 V, 2.5 V,	V _{IN} = V _{CC} or 0 V		1.5	2.5	pF
C _{io(OFF)}		V _{CC} = 3.3 V, 2.5 V,	V _{I/O} = V _{CC} or 0 V, Switch OFF		3.5	5	pF
C _{io(ON)}		V _{CC} = 3.3 V, 2.5 V,	V _{I/O} = V _{CC} or 0 V, Switch ON		6	7.5	pF
r _{ON} ⁽⁵⁾		V _{CC} = 3 V, 2.3 V		V _I = 0 V, I _O = 30 mA		3	Ω
				V _I = 2.4 V, I _O = -15 mA		3.4	
Δr _{ON}		V _{CC} = 3 V, 2.3 V		V _I = 0 V, I _O = 30 mA		0.2	Ω
				V _I = 1.7, I _O = -15 mA		0.2	
r _{ON(flat)}		V _{CC} = 3 V, 2.3 V		V _I = 0 V, I _O = 30 mA		1	Ω
				V _I = 1.7, I _O = -15 mA		1	

- (1) V_{IN} and I_{IN} refer to control inputs. V_I, V_O, I_I, and I_O refer to data pins.
- (2) All typical values are at V_{CC} = 3.3 V (unless otherwise noted), T_A = 25°C.
- (3) For I/O ports, the parameter I_{OZ} includes the input leakage current.
- (4) This is the increase in supply current for each input that is at the specified TTL voltage level, rather than V_{CC} or GND.
- (5) Measured by the voltage drop between the A and B terminals at the indicated current through the switch. ON-state resistance is determined by the lower of the voltages of the two (A or B) terminals.

DYNAMIC ELECTRICAL CHARACTERISTICS

over operating range, T_A = -40°C to 85°C, V_{CC} = 3.3 V ±10%, GND = 0 V

PARAMETER		TEST CONDITIONS	TYP	UNIT
X _{TALK}	Crosstalk	R _L = 50 , f = 250 MHz	-40	dB
O _{IRR}	OFF isolation	R _L = 50 , f = 250 MHz	-41	dB
BW	Bandwidth (-3 dB)	R _L = 50	0.9	GHz

DYNAMIC ELECTRICAL CHARACTERISTICS

 over operating range, $T_A = -40^{\circ}\text{C}$ to 85°C , $V_{CC} = 2.5\text{ V} \pm 10\%$, $\text{GND} = 0\text{ V}$

	PARAMETER	TEST CONDITIONS	TYP	UNIT
X_{TALK}	Crosstalk	$R_L = 50$, $f = 250\text{ MHz}$	-39	dB
O_{IRR}	OFF isolation	$R_L = 50$, $f = 250\text{ MHz}$	-40	dB
BW	Bandwidth (3 dB)	$R_L = 50$	0.9	GHz

SWITCHING CHARACTERISTICS

 over operating range, $T_A = -40^{\circ}\text{C}$ to 85°C , $V_{CC} = 3.3\text{ V} \pm 10\%$, $\text{GND} = 0\text{ V}$

	PARAMETER		MIN	TYP ⁽¹⁾	MAX	UNIT
t_{pd}	Propagation delay ⁽²⁾⁽³⁾			0.25		ns
t_{ON}	Line enable time	S to D, nD			30	ns
		$\overline{\text{OE}}$ to D, nD			17	
t_{OFF}	Line disable time	S to D, nD			12	ns
		$\overline{\text{OE}}$ to D, nD			10	
$t_{\text{SK(O)}}$	Output skew between center port to any other port ⁽²⁾			0.1	0.2	ns
$t_{\text{SK(P)}}$	Skew between opposite transitions of the same output ($t_{\text{PHL}} - t_{\text{PLH}}$) ⁽²⁾			0.1	0.2	ns

(1) For Max or Min conditions, use the appropriate value specified under Electrical Characteristics for the applicable device type.

(2) Specified by design

(3) The bus switch contributes no propagational delay other than the RC delay of the on resistance of the switch and the load capacitance. The time constant for the switch alone is of the order of 0.25 ns for 10-pF load. Since this time constant is much smaller than the rise/fall times of typical driving signals, it adds very little propagational delay to the system. Propagational delay of the bus switch, when used in a system, is determined by the driving circuit on the driving side of the switch and its interactions with the load on the driven side.

SWITCHING CHARACTERISTICS

 over operating range, $T_A = -40^{\circ}\text{C}$ to 85°C , $V_{CC} = 2.5\text{ V} \pm 10\%$, $\text{GND} = 0\text{ V}$

	PARAMETER		MIN	TYP ⁽¹⁾	MAX	UNIT
t_{pd}	Propagation delay ⁽²⁾⁽³⁾			0.25		ns
t_{ON}	Line enable time	S to D, nD			50	ns
		$\overline{\text{OE}}$ to D, nD			32	
t_{OFF}	Line disable time	S to D, nD			23	ns
		$\overline{\text{OE}}$ to D, nD			12	
$t_{\text{SK(O)}}$	Output skew between center port to any other port ⁽²⁾			0.1	0.2	ns
$t_{\text{SK(P)}}$	Skew between opposite transitions of the same output ($t_{\text{PHL}} - t_{\text{PLH}}$) ⁽²⁾			0.1	0.2	ns

(1) For Max or Min conditions, use the appropriate value specified under Electrical Characteristics for the applicable device type.

(2) Specified by design

(3) The bus switch contributes no propagational delay other than the RC delay of the on resistance of the switch and the load capacitance. The time constant for the switch alone is of the order of 0.25 ns for 10-pF load. Since this time constant is much smaller than the rise/fall times of typical driving signals, it adds very little propagational delay to the system. Propagational delay of the bus switch, when used in a system, is determined by the driving circuit on the driving side of the switch and its interactions with the load on the driven side.

APPLICATION INFORMATION

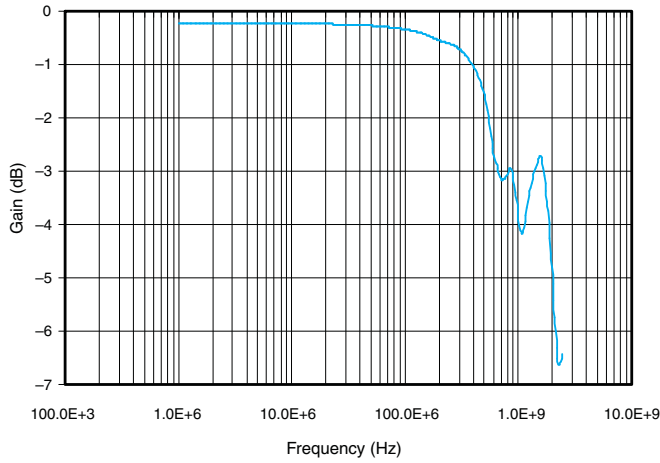

Figure 1. Gain vs Frequency

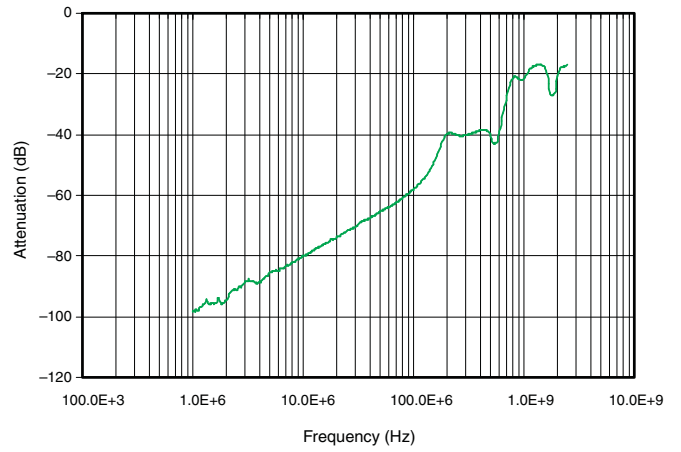

Figure 2. OFF Isolation vs Frequency

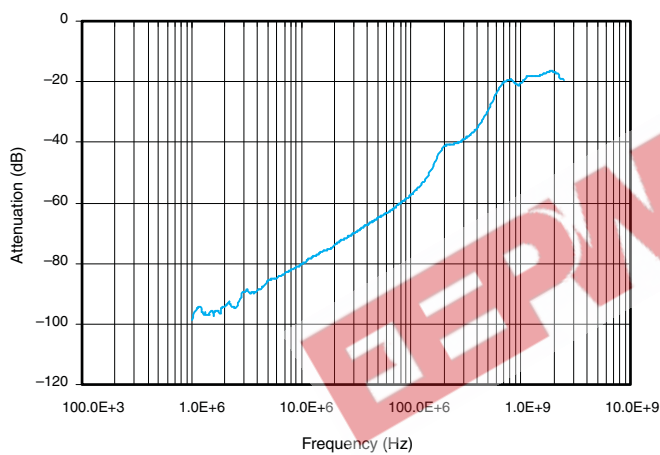

Figure 3. Crosstalk vs Frequency

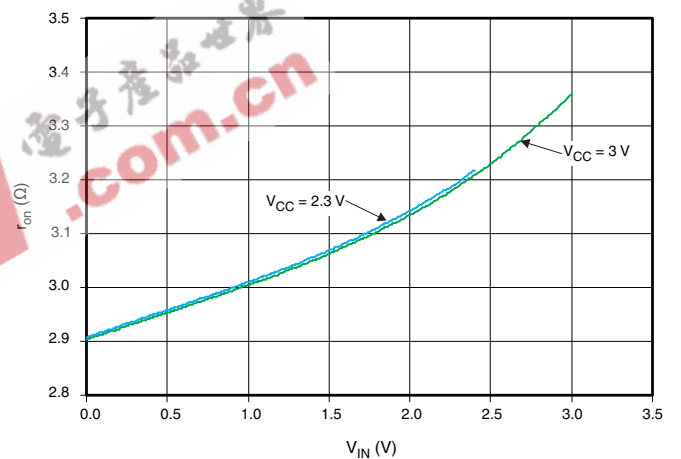

Figure 4. r_{on} vs V_{IN} ($I_{OUT} = -15$ mA)

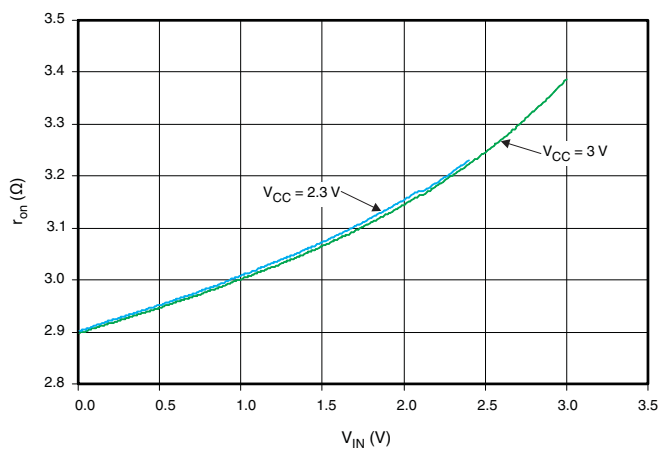

Figure 5. r_{ON} vs V_{IN} ($I_{OUT} = 30$ mA)

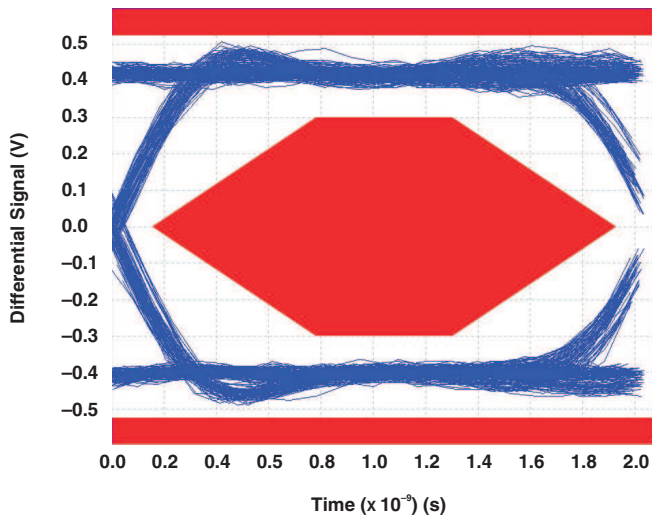

Figure 6. Eye Pattern: 480-Mbps USB Signal With No Switch (Through Path)

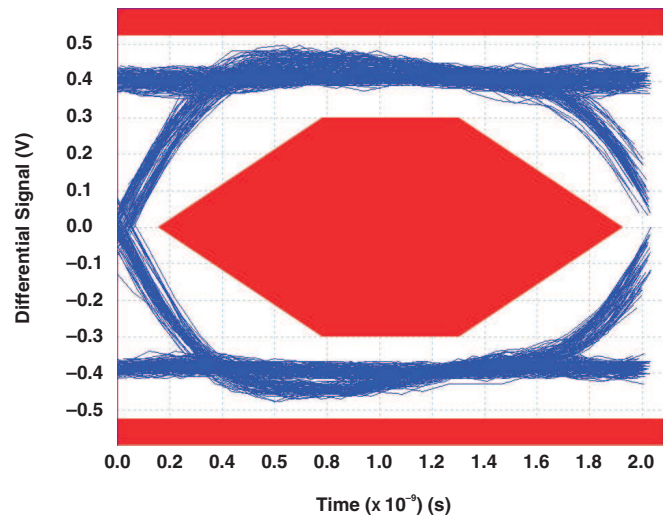

Figure 7. Eye Pattern: 480-Mbps USB Signal With Switch NC Path

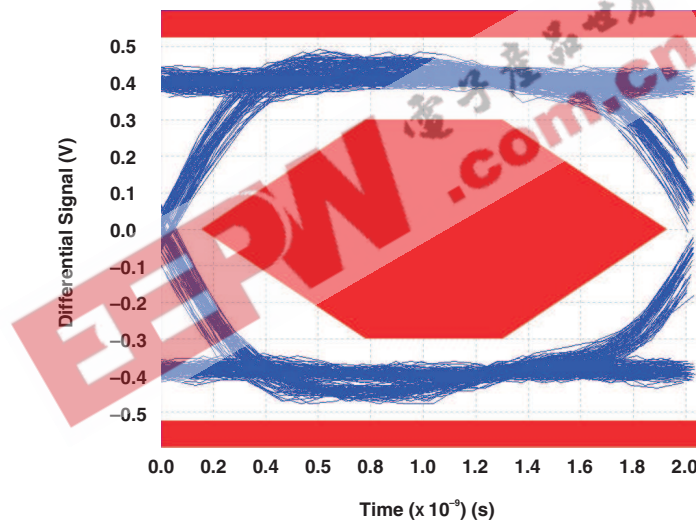
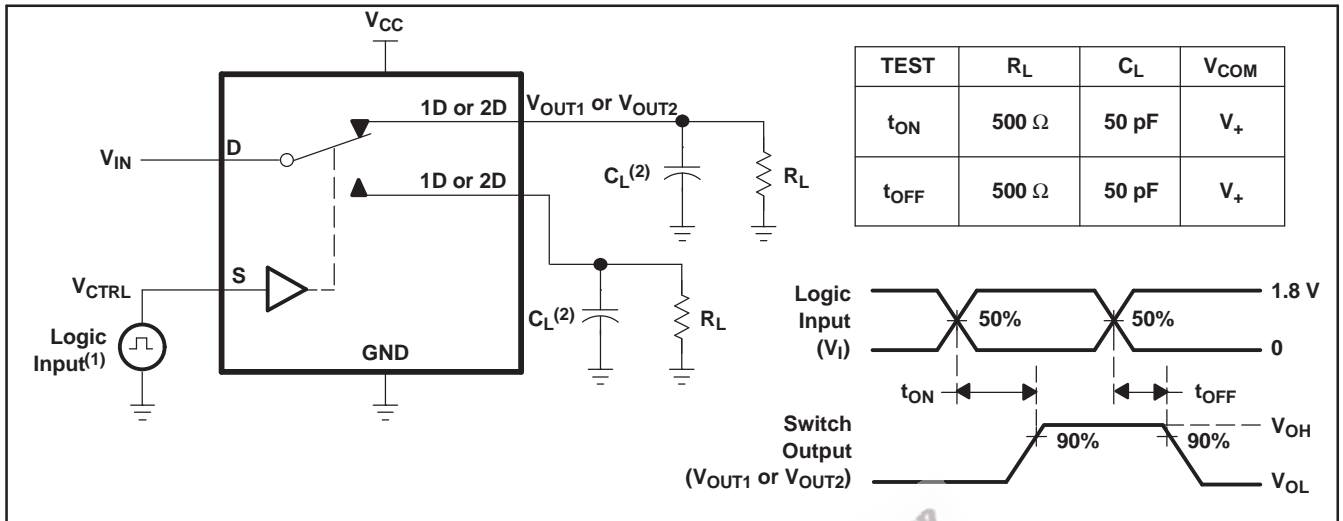

Figure 8. Eye Pattern: 480-Mbps USB Signal With Switch NO Path

PARAMETER MEASUREMENT INFORMATION



- (1) All input pulses are supplied by generators having the following characteristics: PRR ≤ 10 MHz, Z_O = 50 Ω, t_r < 5 ns, t_f < 5 ns.
- (2) C_L includes probe and jig capacitance.

Figure 9. Turn-On (t_{ON}) and Turn-Off Time (t_{OFF})

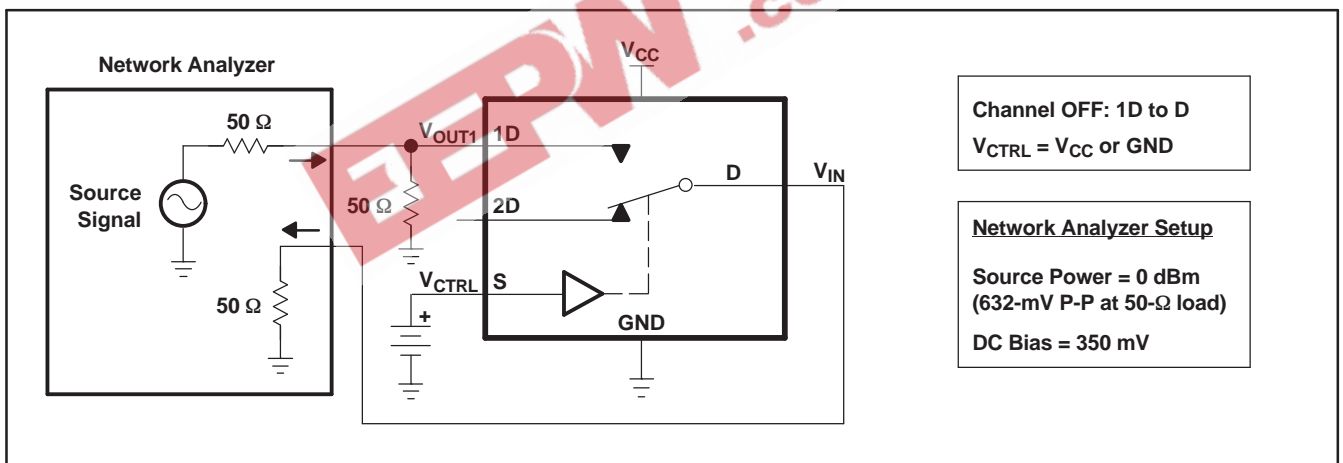

Figure 10. OFF Isolation (O_{ISO})

PARAMETER MEASUREMENT INFORMATION (continued)

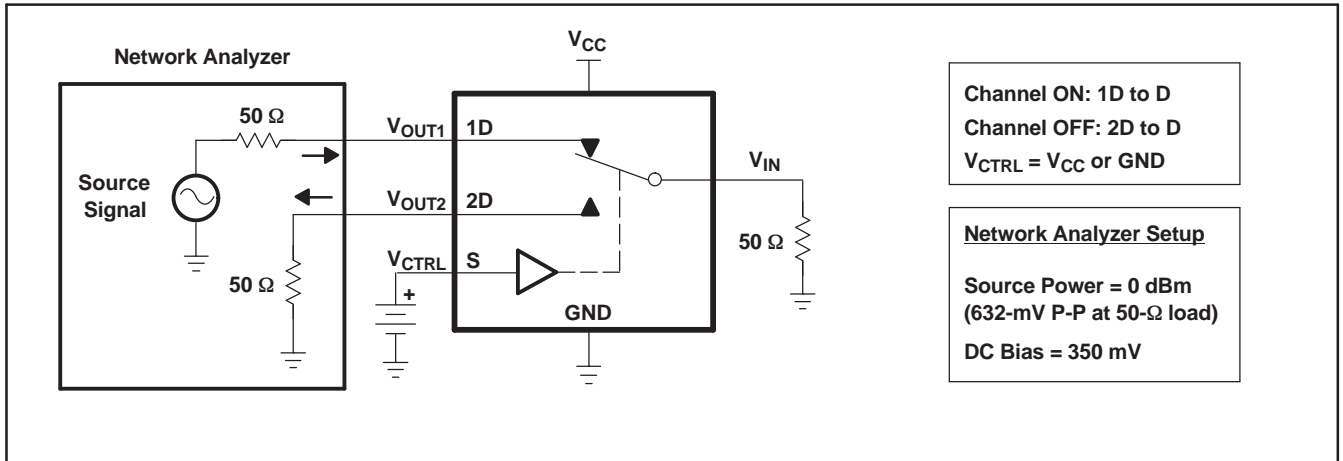

Figure 11. Crosstalk (X_{TALK})

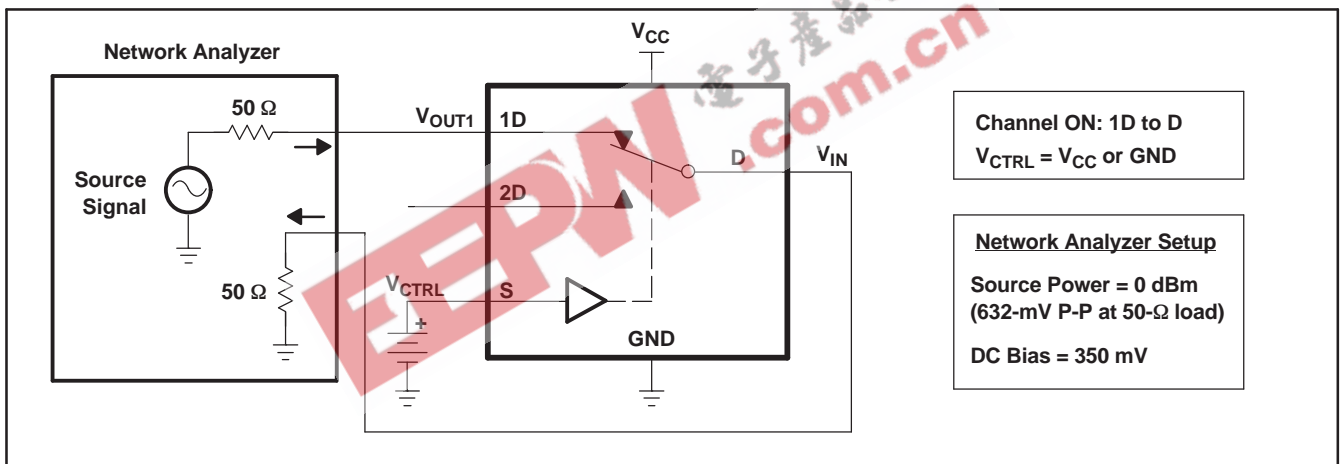

Figure 12. Bandwidth (BW)

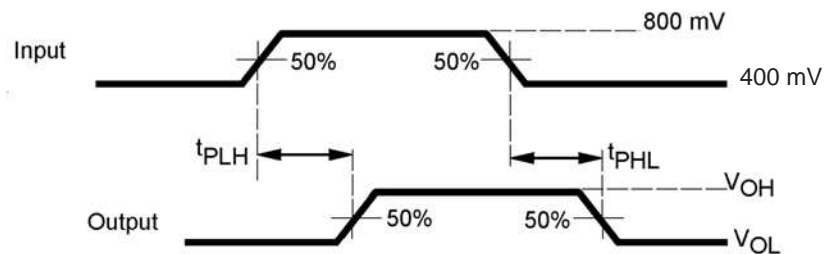

Figure 13. Propagation Delay

PARAMETER MEASUREMENT INFORMATION (continued)

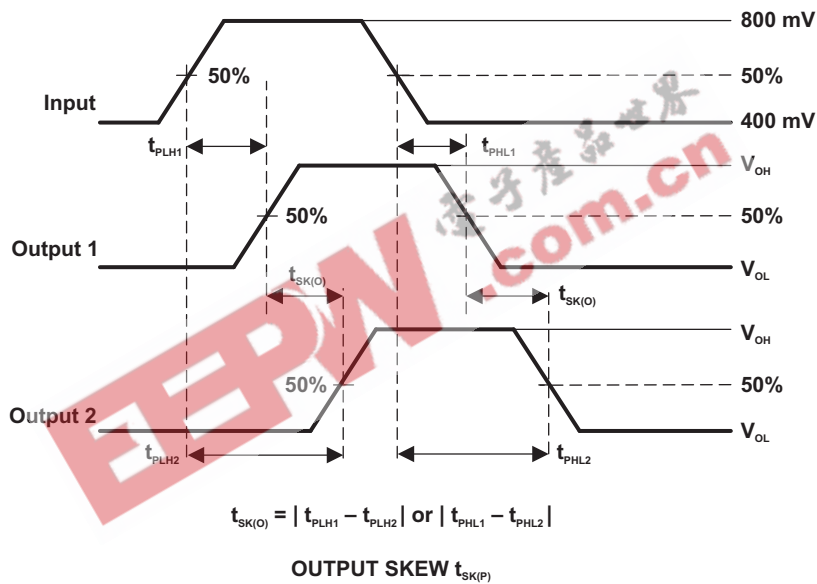
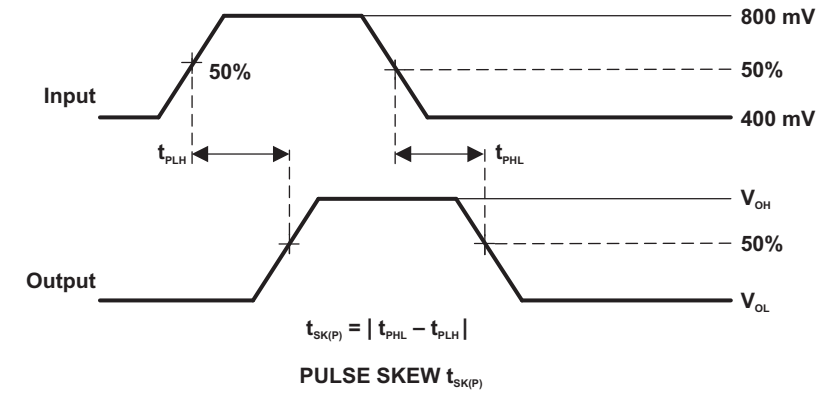

Figure 14. Skew Test

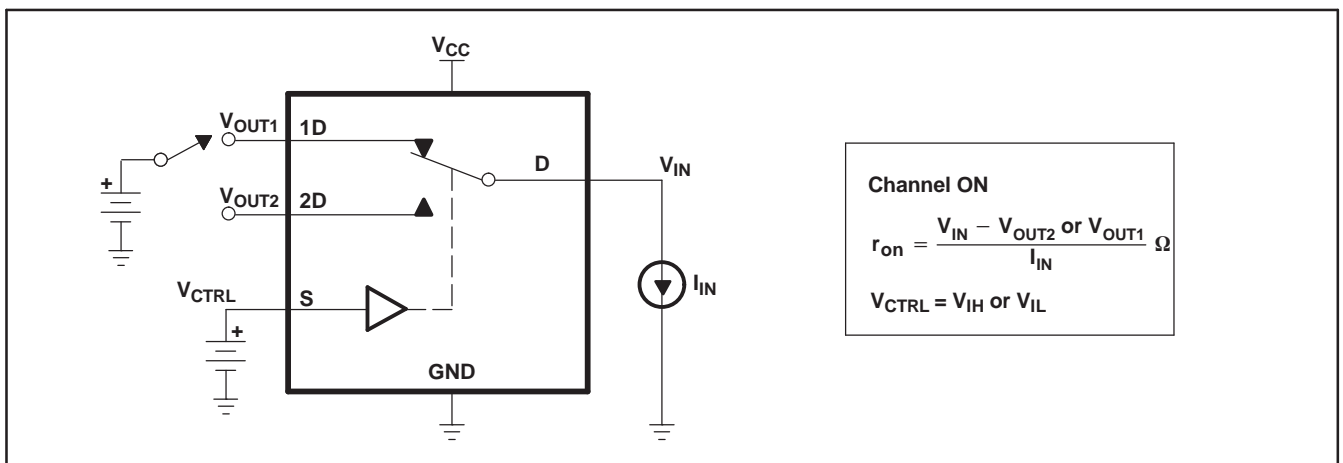

Figure 15. ON-State Resistance (r_{on})

PARAMETER MEASUREMENT INFORMATION (continued)

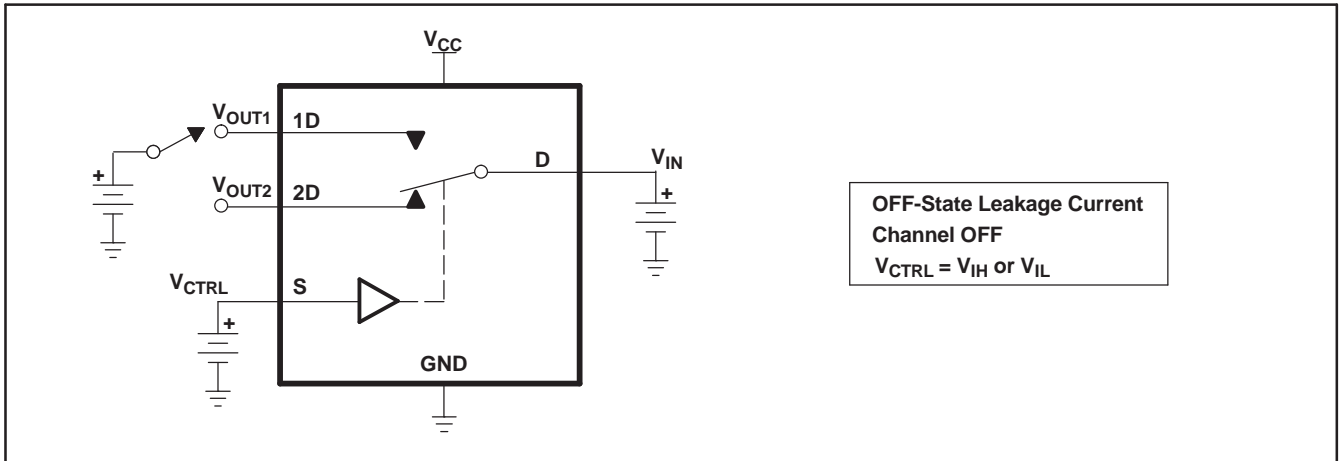

Figure 16. OFF-State Leakage Current

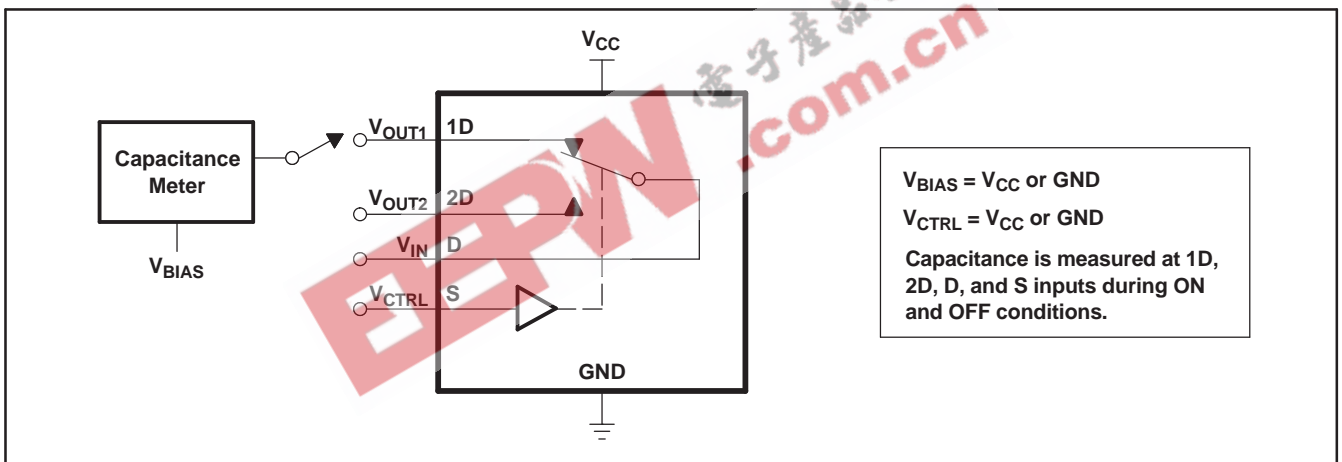

Figure 17. Capacitance

PACKAGING INFORMATION

Orderable Device	Status ⁽¹⁾	Package Type	Package Drawing	Pins	Package Qty	Eco Plan ⁽²⁾	Lead/Ball Finish	MSL Peak Temp ⁽³⁾
TS3USB221ARSER	ACTIVE	QFN	RSE	10	3000	Green (RoHS & no Sb/Br)	Cu NIPDAU	Level-1-260C-UNLIM
TS3USB221ARSERG4	ACTIVE	QFN	RSE	10	3000	Green (RoHS & no Sb/Br)	Cu NIPDAU	Level-1-260C-UNLIM

⁽¹⁾ The marketing status values are defined as follows:

ACTIVE: Product device recommended for new designs.

LIFEBUY: TI has announced that the device will be discontinued, and a lifetime-buy period is in effect.

NRND: Not recommended for new designs. Device is in production to support existing customers, but TI does not recommend using this part in a new design.

PREVIEW: Device has been announced but is not in production. Samples may or may not be available.

OBSOLETE: TI has discontinued the production of the device.

⁽²⁾ Eco Plan - The planned eco-friendly classification: Pb-Free (RoHS), Pb-Free (RoHS Exempt), or Green (RoHS & no Sb/Br) - please check <http://www.ti.com/productcontent> for the latest availability information and additional product content details.

TBD: The Pb-Free/Green conversion plan has not been defined.

Pb-Free (RoHS): TI's terms "Lead-Free" or "Pb-Free" mean semiconductor products that are compatible with the current RoHS requirements for all 6 substances, including the requirement that lead not exceed 0.1% by weight in homogeneous materials. Where designed to be soldered at high temperatures, TI Pb-Free products are suitable for use in specified lead-free processes.

Pb-Free (RoHS Exempt): This component has a RoHS exemption for either 1) lead-based flip-chip solder bumps used between the die and package, or 2) lead-based die adhesive used between the die and leadframe. The component is otherwise considered Pb-Free (RoHS compatible) as defined above.

Green (RoHS & no Sb/Br): TI defines "Green" to mean Pb-Free (RoHS compatible), and free of Bromine (Br) and Antimony (Sb) based flame retardants (Br or Sb do not exceed 0.1% by weight in homogeneous material)

⁽³⁾ MSL, Peak Temp. -- The Moisture Sensitivity Level rating according to the JEDEC industry standard classifications, and peak solder temperature.

Important Information and Disclaimer: The information provided on this page represents TI's knowledge and belief as of the date that it is provided. TI bases its knowledge and belief on information provided by third parties, and makes no representation or warranty as to the accuracy of such information. Efforts are underway to better integrate information from third parties. TI has taken and continues to take reasonable steps to provide representative and accurate information but may not have conducted destructive testing or chemical analysis on incoming materials and chemicals. TI and TI suppliers consider certain information to be proprietary, and thus CAS numbers and other limited information may not be available for release.

In no event shall TI's liability arising out of such information exceed the total purchase price of the TI part(s) at issue in this document sold by TI to Customer on an annual basis.

TAPE AND REEL INFORMATION

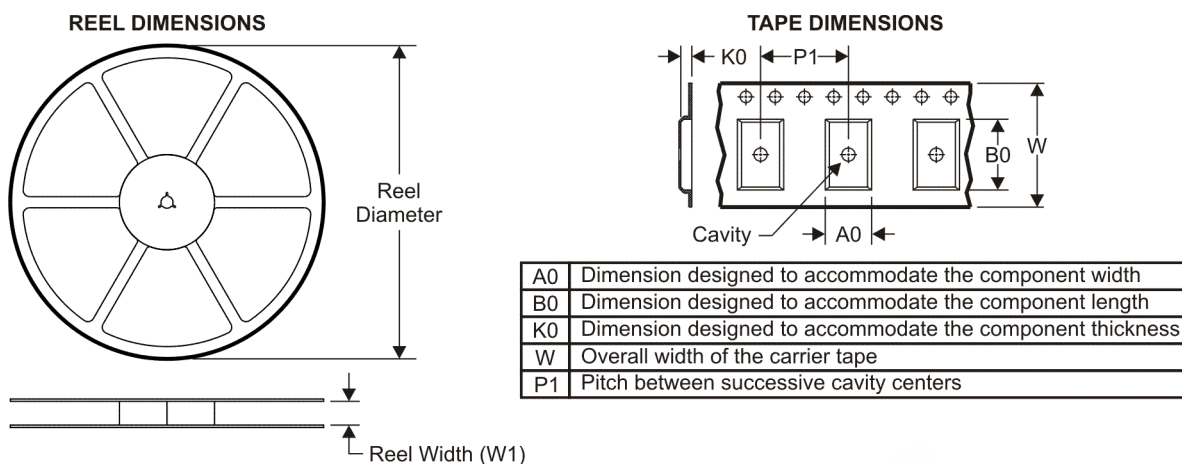

QUADRANT ASSIGNMENTS FOR PIN 1 ORIENTATION IN TAPE

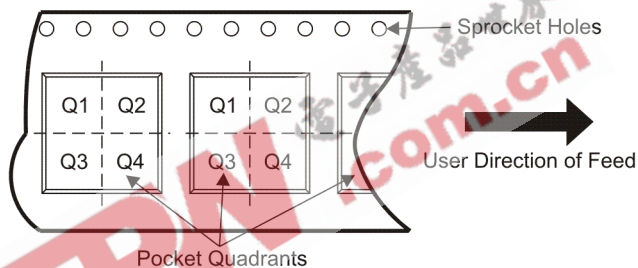

*All dimensions are nominal

Device	Package Type	Package Drawing	Pins	SPQ	Reel Diameter (mm)	Reel Width W1 (mm)	A0 (mm)	B0 (mm)	K0 (mm)	P1 (mm)	W (mm)	Pin1 Quadra
TS3USB221ARSER	QFN	RSE	10	3000	180.0	8.4	1.68	2.13	0.76	4.0	8.0	Q1

TAPE AND REEL BOX DIMENSIONS

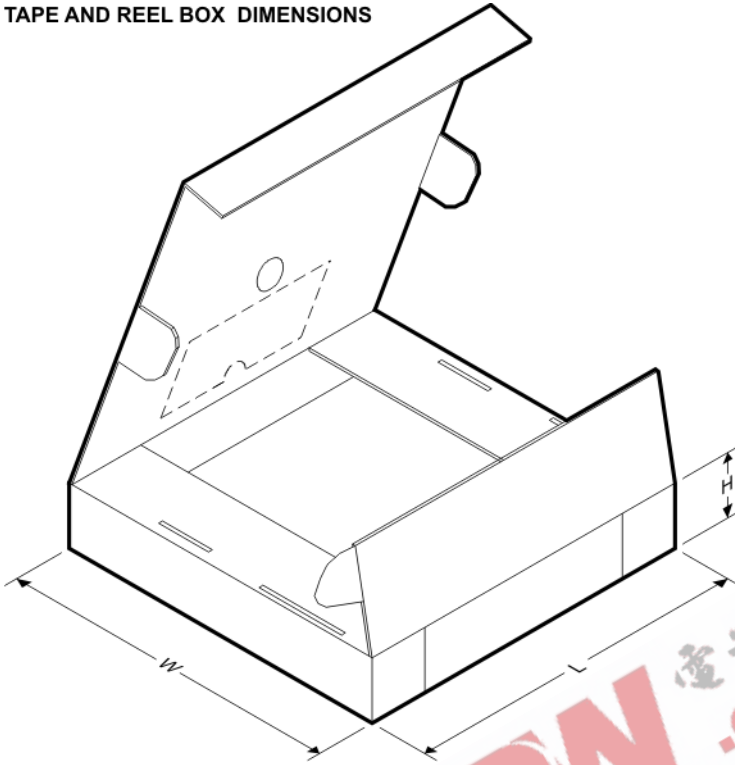

*All dimensions are nominal

Device	Package Type	Package Drawing	Pins	SPQ	Length (mm)	Width (mm)	Height (mm)
TS3USB221ARSER	QFN	RSE	10	3000	202.0	201.0	28.0

MECHANICAL DATA

RSE (R-PQFP-N10)

PLASTIC QUAD FLATPACK

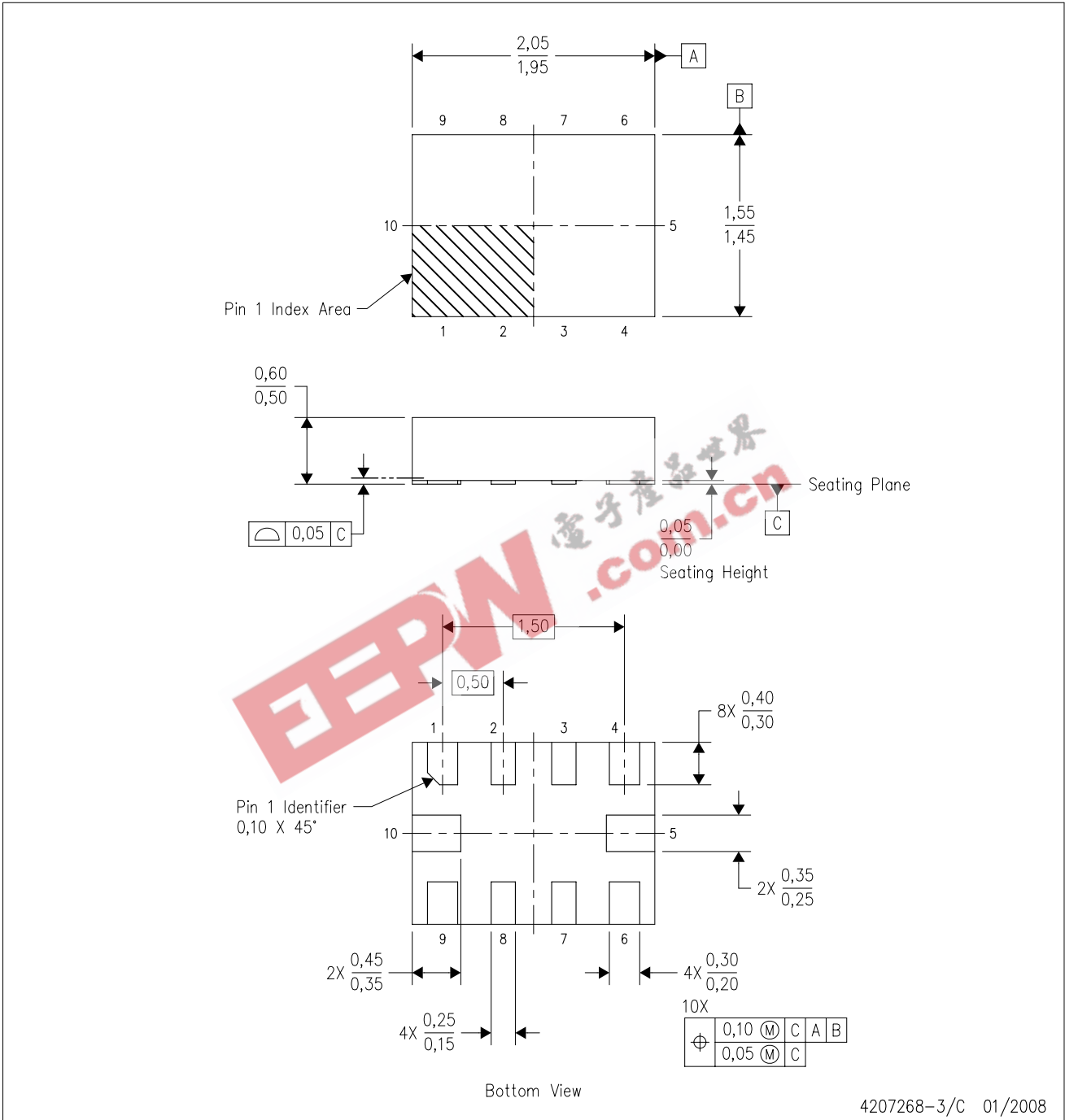

4207268-3/C 01/2008

- NOTES:
- A. All linear dimensions are in millimeters. Dimensioning and tolerancing per ASME Y14.5M-1994.
 - B. This drawing is subject to change without notice.
 - C. QFN (Quad Flatpack No-Lead) package configuration.
 - D. This package complies to JEDEC MO-288 variation UEFD.

IMPORTANT NOTICE

Texas Instruments Incorporated and its subsidiaries (TI) reserve the right to make corrections, modifications, enhancements, improvements, and other changes to its products and services at any time and to discontinue any product or service without notice. Customers should obtain the latest relevant information before placing orders and should verify that such information is current and complete. All products are sold subject to TI's terms and conditions of sale supplied at the time of order acknowledgment.

TI warrants performance of its hardware products to the specifications applicable at the time of sale in accordance with TI's standard warranty. Testing and other quality control techniques are used to the extent TI deems necessary to support this warranty. Except where mandated by government requirements, testing of all parameters of each product is not necessarily performed.

TI assumes no liability for applications assistance or customer product design. Customers are responsible for their products and applications using TI components. To minimize the risks associated with customer products and applications, customers should provide adequate design and operating safeguards.

TI does not warrant or represent that any license, either express or implied, is granted under any TI patent right, copyright, mask work right, or other TI intellectual property right relating to any combination, machine, or process in which TI products or services are used. Information published by TI regarding third-party products or services does not constitute a license from TI to use such products or services or a warranty or endorsement thereof. Use of such information may require a license from a third party under the patents or other intellectual property of the third party, or a license from TI under the patents or other intellectual property of TI.

Reproduction of TI information in TI data books or data sheets is permissible only if reproduction is without alteration and is accompanied by all associated warranties, conditions, limitations, and notices. Reproduction of this information with alteration is an unfair and deceptive business practice. TI is not responsible or liable for such altered documentation. Information of third parties may be subject to additional restrictions.

Resale of TI products or services with statements different from or beyond the parameters stated by TI for that product or service voids all express and any implied warranties for the associated TI product or service and is an unfair and deceptive business practice. TI is not responsible or liable for any such statements.

TI products are not authorized for use in safety-critical applications (such as life support) where a failure of the TI product would reasonably be expected to cause severe personal injury or death, unless officers of the parties have executed an agreement specifically governing such use. Buyers represent that they have all necessary expertise in the safety and regulatory ramifications of their applications, and acknowledge and agree that they are solely responsible for all legal, regulatory and safety-related requirements concerning their products and any use of TI products in such safety-critical applications, notwithstanding any applications-related information or support that may be provided by TI. Further, Buyers must fully indemnify TI and its representatives against any damages arising out of the use of TI products in such safety-critical applications.

TI products are neither designed nor intended for use in military/aerospace applications or environments unless the TI products are specifically designated by TI as military-grade or "enhanced plastic." Only products designated by TI as military-grade meet military specifications. Buyers acknowledge and agree that any such use of TI products which TI has not designated as military-grade is solely at the Buyer's risk, and that they are solely responsible for compliance with all legal and regulatory requirements in connection with such use.

TI products are neither designed nor intended for use in automotive applications or environments unless the specific TI products are designated by TI as compliant with ISO/TS 16949 requirements. Buyers acknowledge and agree that, if they use any non-designated products in automotive applications, TI will not be responsible for any failure to meet such requirements.

Following are URLs where you can obtain information on other Texas Instruments products and application solutions:

Products

Amplifiers	amplifier.ti.com
Data Converters	dataconverter.ti.com
DSP	dsp.ti.com
Clocks and Timers	www.ti.com/clocks
Interface	interface.ti.com
Logic	logic.ti.com
Power Mgmt	power.ti.com
Microcontrollers	microcontroller.ti.com
RFID	www.ti-rfid.com
RF/IF and ZigBee® Solutions	www.ti.com/lprf

Applications

Audio	www.ti.com/audio
Automotive	www.ti.com/automotive
Broadband	www.ti.com/broadband
Digital Control	www.ti.com/digitalcontrol
Medical	www.ti.com/medical
Military	www.ti.com/military
Optical Networking	www.ti.com/opticalnetwork
Security	www.ti.com/security
Telephony	www.ti.com/telephony
Video & Imaging	www.ti.com/video
Wireless	www.ti.com/wireless

Mailing Address: Texas Instruments, Post Office Box 655303, Dallas, Texas 75265
Copyright © 2008, Texas Instruments Incorporated