

# 74ALVCH16373

## Low-Voltage 16-Bit Transparent Latch with Bus Hold 1.8/2.5/3.3 V

(3-State, Non-Inverting)

The 74ALVCH16373 is an advanced performance, non-inverting 16-bit transparent latch. It is designed for very high-speed, very low-power operation in 1.8 V, 2.5 V or 3.3 V systems. The VCXH16373 is byte controlled, with each byte functioning identically, but independently. Each byte has separate Output Enable and Latch Enable inputs. These control pins can be tied together for full 16-bit operation.

The 74ALVCH16373 contains 16 D-type latches with 3-state 3.6 V-tolerant outputs. When the Latch Enable (LEn) inputs are HIGH, data on the Dn inputs enters the latches. In this condition, the latches are transparent, (a latch output will change state each time its D input changes). When LE is LOW, the latch stores the information that was present on the D inputs a setup time preceding the HIGH-to-LOW transition of LE. The 3-state outputs are controlled by the Output Enable ( $\overline{OE}$ n) inputs. When  $\overline{OE}$  is LOW, the outputs are enabled. When  $\overline{OE}$  is HIGH, the standard outputs are in the high impedance state, but this does not interfere with new data entering into the latches. The data inputs include active bushold circuitry, eliminating the need for external pull-up resistors to hold unused or floating inputs at a valid logic state.

- Designed for Low Voltage Operation:  $V_{CC} = 1.65 - 3.6$  V
- 3.6 V Tolerant Inputs and Outputs
- High Speed Operation: 3.6 ns max for 3.0 to 3.6 V  
4.5 ns max for 2.3 to 2.7 V  
6.8 ns max for 1.65 to 1.95 V
- Static Drive:  $\pm 24$  mA Drive at 3.0 V  
 $\pm 12$  mA Drive at 2.3 V  
 $\pm 4$  mA Drive at 1.65 V
- Supports Live Insertion and Withdrawal
- Includes Active Bushold to Hold Unused or Floating Inputs at a Valid Logic State
- $I_{OFF}$  Specification Guarantees High Impedance When  $V_{CC} = 0$  V<sup>†</sup>
- Near Zero Static Supply Current in All Three Logic States (40  $\mu$ A)  
Substantially Reduces System Power Requirements
- Latchup Performance Exceeds  $\pm 250$  mA @ 125°C
- ESD Performance: Human Body Model >2000V; Machine Model >200V
- Second Source to Industry Standard 74ALVCH16373

<sup>†</sup>To ensure the outputs activate in the 3-state condition, the output enable pins should be connected to  $V_{CC}$  through a pull-up resistor. The value of the resistor is determined by the current sinking capability of the output connected to the OE pin.



ON Semiconductor®

<http://onsemi.com>

### MARKING DIAGRAM

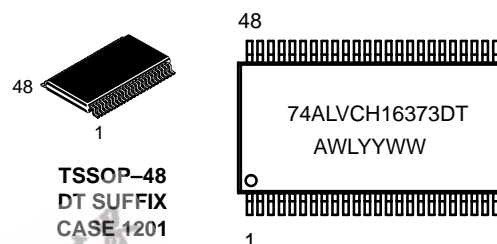

A = Assembly Location  
WL = Wafer Lot  
YY = Year  
WW = Work Week

### PIN NAMES

Pins	Function
$\overline{OE}$ n	Output Enable Inputs
LEn	Latch Enable Inputs
D0-D15	Inputs
O0-O15	Outputs

### ORDERING INFORMATION

Device	Package	Shipping
74ALVCH16373DTR	TSSOP	2500/Tape & Reel

# 74ALVCH16373

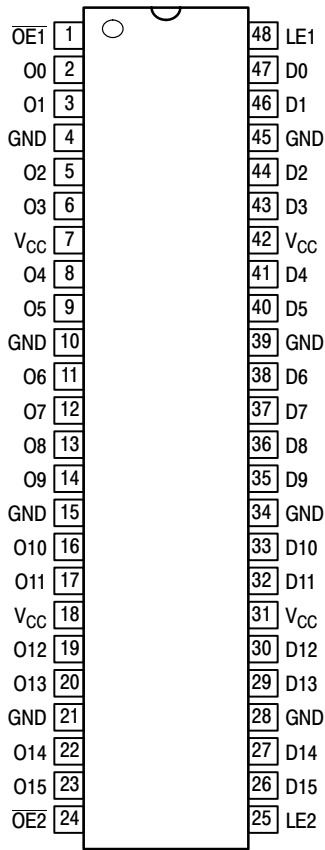

Figure 1. 48-Lead Pinout (Top View)

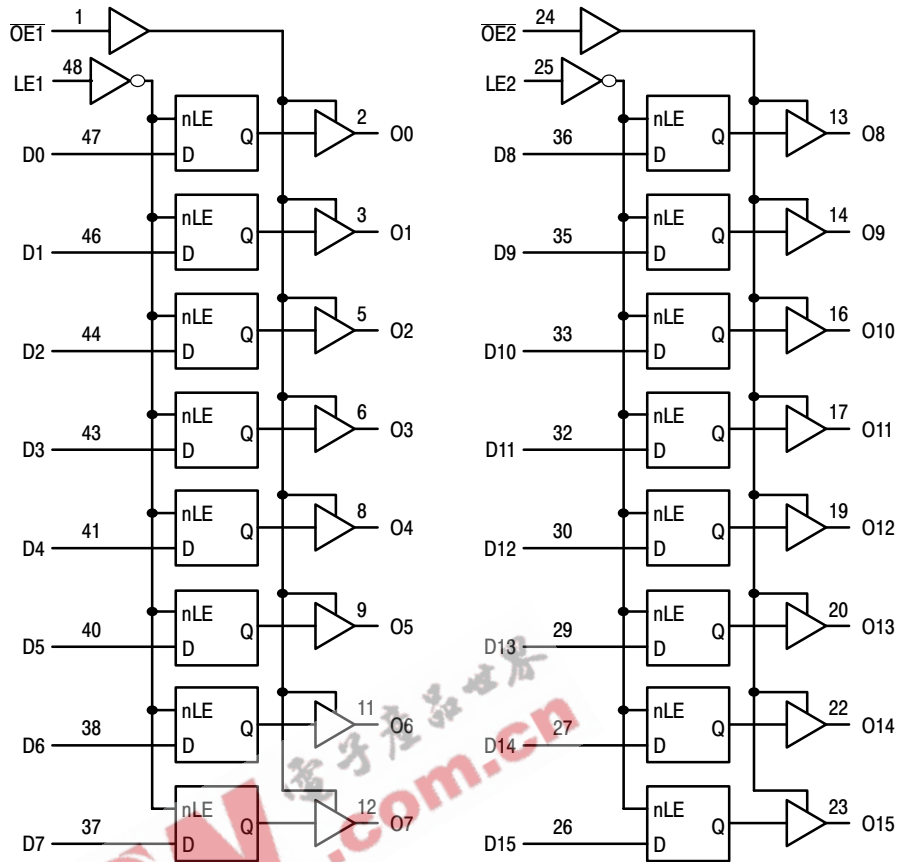

Figure 2. Logic Diagram

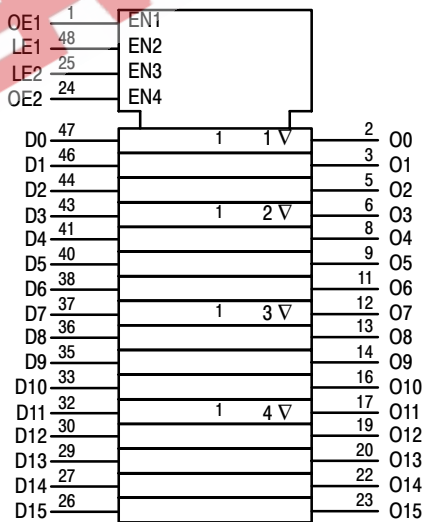

Figure 3. IEC Logic Diagram

Inputs			Outputs	Inputs			Outputs
LE1	OE1	D0:7	O0:7	LE2	OE2	D8:15	O8:15
X	H	X	Z	X	H	X	Z
H	L	L	L	H	L	L	L
H	L	H	H	H	L	H	H
L	L	X	O0	L	L	X	O0

H = High Voltage Level; L = Low Voltage Level; Z = High Impedance State; X = High or Low Voltage Level and Transitions Are Acceptable, for I<sub>CC</sub> reasons, DO NOT FLOAT Inputs. O0 = No Change.

# 74ALVCH16373

## MAXIMUM RATINGS (Note 1)

Symbol	Parameter	Value	Unit
V <sub>CC</sub>	DC Supply Voltage	− 0.5 to + 4.6	V
V <sub>I</sub>	DC Input Voltage	− 0.5 to + 4.6	V
V <sub>O</sub>	DC Output Voltage	− 0.5 to + 4.6	V
I <sub>IK</sub>	DC Input Diode Current V <sub>I</sub> < GND	− 50	mA
I <sub>OK</sub>	DC Output Diode Current V <sub>O</sub> < GND	− 50	mA
I <sub>O</sub>	DC Output Sink Current	± 50	mA
I <sub>CC</sub>	DC Supply Current per Supply Pin	± 100	mA
I <sub>GND</sub>	DC Ground Current per Ground Pin	± 100	mA
T <sub>STG</sub>	Storage Temperature Range	− 65 to + 150	°C
T <sub>L</sub>	Lead Temperature, 1 mm from Case for 10 Seconds	260	°C
T <sub>J</sub>	Junction Temperature Under Bias	+ 150	°C
θ <sub>JA</sub>	Thermal Resistance (Note 2)	90	°C/W
MSL	Moisture Sensitivity	Level 1	
F <sub>R</sub>	Flammability Rating Oxygen Index: 30 to 35	UL 94 V-O @ 0.125 in	
V <sub>ESD</sub>	ESD Withstand Voltage Human Body Model (Note 3) Machine Model (Note 4) Charged Device Model (Note 5)	> 2000 > 200 N/A	V
I <sub>LATCH-UP</sub>	Latch-Up Performance Above V <sub>CC</sub> and Below GND at 125°C (Note 6)	± 250	mA

Maximum Ratings are those values beyond which damage to the device may occur. Exposure to these conditions or conditions beyond those indicated may adversely affect device reliability. Functional operation under absolute maximum-rated conditions is not implied. Functional operation should be restricted to the Recommended Operating Conditions.

1. I<sub>O</sub> absolute maximum rating must be observed.
2. Measured with minimum pad spacing on an FR4 board, using 10 mm-by-1 inch, 2-ounce copper trace with no air flow.
3. Tested to EIA/JESD22-A114-A.
4. Tested to EIA/JESD22-A115-A.
5. Tested to JESD22-C101-A.
6. Tested to EIA/JESD78.

## RECOMMENDED OPERATING CONDITIONS

Symbol	Parameter	Min	Max	Unit
V <sub>CC</sub>	Supply Voltage Operating Data Retention Only	2.3 1.5	3.6 3.6	V
V <sub>I</sub>	Input Voltage (Note 7)	− 0.5	3.6	V
V <sub>O</sub>	Output Voltage (Active State) (3-State)	0 0	3.6 3.6	V
T <sub>A</sub>	Operating Free-Air Temperature	− 40	+ 85	°C
Δt/ΔV	Input Transition Rise or Fall Rate V <sub>CC</sub> = 2.5 V ± 0.2 V V <sub>CC</sub> = 3.0 V ± 0.3 V	0 0	20 10	ns/V

7. Unused inputs may not be left open. All inputs must be tied to a high-logic voltage level or a low-logic input voltage level.

## 74ALVCH16373

### DC ELECTRICAL CHARACTERISTICS

Symbol	Parameter	Condition	$T_A = -40^\circ\text{C to } +85^\circ\text{C}$		Unit
			Min	Max	
$V_{IH}$	HIGH Level Input Voltage (Note 8)	$1.65\text{ V} \leq V_{CC} < 2.3\text{ V}$	$0.65 \times V_{CC}$		V
		$2.3\text{ V} \leq V_{CC} \leq 2.7\text{ V}$	1.7		
		$2.7\text{ V} < V_{CC} \leq 3.6\text{ V}$	2.0		
$V_{IL}$	LOW Level Input Voltage (Note 8)	$1.65\text{ V} \leq V_{CC} < 2.3\text{ V}$		$0.35 \times V_{CC}$	V
		$2.3\text{ V} \leq V_{CC} \leq 2.7\text{ V}$		0.7	
		$2.7\text{ V} < V_{CC} \leq 3.6\text{ V}$		0.8	
$V_{OH}$	HIGH Level Output Voltage	$1.65\text{ V} \leq V_{CC} \leq 3.6\text{ V}; I_{OH} = -100\ \mu\text{A}$	$V_{CC} - 0.2$		V
		$V_{CC} = 1.65\text{ V}; I_{OH} = -4\text{ mA}$	1.2		
		$V_{CC} = 2.3\text{ V}; I_{OH} = -6\text{ mA}$	2.0		
		$V_{CC} = 2.3\text{ V}; I_{OH} = -12\text{ mA}$	1.7		
		$V_{CC} = 2.7\text{ V}; I_{OH} = -12\text{ mA}$	2.2		
		$V_{CC} = 3.0\text{ V}; I_{OH} = -12\text{ mA}$	2.4		
		$V_{CC} = 3.0\text{ V}; I_{OH} = -24\text{ mA}$	2.0		
$V_{OL}$	LOW Level Output Voltage	$1.65\text{ V} \leq V_{CC} \leq 3.6\text{ V}; I_{OL} = 100\ \mu\text{A}$		0.2	V
		$V_{CC} = 1.65\text{ V}; I_{OL} = 4\text{ mA}$		0.45	
		$V_{CC} = 2.3\text{ V}; I_{OL} = 6\text{ mA}$		0.4	
		$V_{CC} = 2.3\text{ V}; I_{OL} = 12\text{ mA}$		0.7	
		$V_{CC} = 2.7\text{ V}; I_{OL} = 12\text{ mA}$		0.4	
		$V_{CC} = 3.0\text{ V}; I_{OL} = 24\text{ mA}$		0.55	
$I_I$	Input Leakage Current	$1.65\text{ V} \leq V_{CC} \leq 3.6\text{ V}; 0\text{ V} \leq V_I \leq 3.6\text{ V}$		$\pm 5.0$	$\mu\text{A}$
$I_{I(\text{HOLD})}$	Minimum Bus-hold Input Current	$V_{CC} = 3.6\text{ V}; V_{IN} = 0\text{ to } 3.6\text{ V}$		$\pm 500$	$\mu\text{A}$
		$V_{CC} = 3.0\text{ V}; V_{IN} = 0.8\text{ V}$	75		
		$V_{CC} = 3.0\text{ V}; V_{IN} = 2.0\text{ V}$	-75		
		$V_{CC} = 2.3\text{ V}; V_{IN} = 0.7\text{ V}$	45		
		$V_{CC} = 2.3\text{ V}; V_{IN} = 1.7\text{ V}$	-45		
		$V_{CC} = 1.65\text{ V}; V_{IN} = 0.58\text{ V}$	25		
		$V_{CC} = 1.65\text{ V}; V_{IN} = 1.07\text{ V}$	-25		
$I_{OZ}$	3-State Output Current	$1.65\text{ V} \leq V_{CC} \leq 3.6\text{ V}; 0\text{ V} \leq V_O \leq 3.6\text{ V}; V_I = V_{IH}\text{ or } V_{IL}$		$\pm 10$	$\mu\text{A}$
$I_{OFF}$	Power-Off Leakage Current	$V_{CC} = 0\text{ V}; V_I\text{ or } V_O = 3.6\text{ V}$		10	$\mu\text{A}$
$I_{CC}$	Quiescent Supply Current (Note 9)	$1.65\text{ V} \leq V_{CC} \leq 3.6\text{ V}; V_I = \text{GND or } V_{CC}$		40	$\mu\text{A}$
		$1.65\text{ V} \leq V_{CC} \leq 3.6\text{ V}; 3.6\text{ V} \leq V_I, V_O \leq 3.6\text{ V}$		$\pm 40$	
$\Delta I_{CC}$	Increase in $I_{CC}$ per Input	$2.7\text{ V} < V_{CC} \leq 3.6\text{ V}; V_{IH} = V_{CC} - 0.6\text{ V}$		750	$\mu\text{A}$

8. These values of  $V_I$  are used to test DC electrical characteristics only.

9. Outputs disabled or 3-state only.

# 74ALVCH16373

**AC CHARACTERISTICS** (Note 10;  $t_R = t_F = 2.0$  ns;  $C_L = 30$  pF;  $R_L = 500$   $\Omega$ )

Symbol	Parameter	Waveform	Limits						Unit
			$T_A = -40^\circ\text{C to } +85^\circ\text{C}$						
			$V_{CC} = 3.0$ V to $3.6$ V		$V_{CC} = 2.3$ V to $2.7$ V		$V_{CC} = 1.65$ V to $1.95$ V		
			Min	Max	Min	Max	Min	Max	
$t_{PLH}$ $t_{PHL}$	Propagation Delay Dn to On	1	1.0 1.0	3.6 3.6	1.0 1.0	4.5 4.5	1.0 1.0	6.8 6.8	ns
$t_{PLH}$ $t_{PHL}$	Propagation Delay LE to On	1	1.0 1.0	3.9 3.9	1.0 1.0	4.9 4.9	1.0 1.0	7.8 7.8	ns
$t_{PZH}$ $t_{PZL}$	Output Enable Time to High and Low Level	2	1.0 1.0	4.7 4.7	1.0 1.0	6.0 6.0	1.0 1.0	9.2 9.2	ns
$t_{PHZ}$ $t_{PLZ}$	Output Disable Time From High and Low Level	2	1.0 1.0	4.1 4.1	1.0 1.0	5.1 5.1	1.0 1.0	6.8 6.8	ns
$t_s$	Setup Time, High or Low Dn to LE	3	1.5		1.5		2.5		ns
$t_h$	Hold Time, High or Low Dn to LE	3	1.0		1.0		1.0		ns
$t_w$	LE Pulse Width, High	3	1.5		1.5		4.0		ns
$t_{OSHL}$ $t_{OSLH}$	Output-to-Output Skew (Note 11)			0.5 0.5		0.5 0.5		0.75 0.75	ns

10. For  $C_L = 50$  pF, add approximately 300 ps to the AC maximum specification.

11. Skew is defined as the absolute value of the difference between the actual propagation delay for any two separate outputs of the same device. The specification applies to any outputs switching in the same direction, either HIGH-to-LOW ( $t_{OSHL}$ ) or LOW-to-HIGH ( $t_{OSLH}$ ); parameter guaranteed by design.

## CAPACITIVE CHARACTERISTICS

Symbol	Parameter	Condition	Typical	Unit
$C_{IN}$	Input Capacitance	Note 12	6	pF
$C_{OUT}$	Output Capacitance	Note 12	7	pF
$C_{PD}$	Power Dissipation Capacitance	Note 12, 10 MHz	20	pF

12.  $V_{CC} = 1.8, 2.5$  or  $3.3$  V;  $V_I = 0$  V or  $V_{CC}$ .

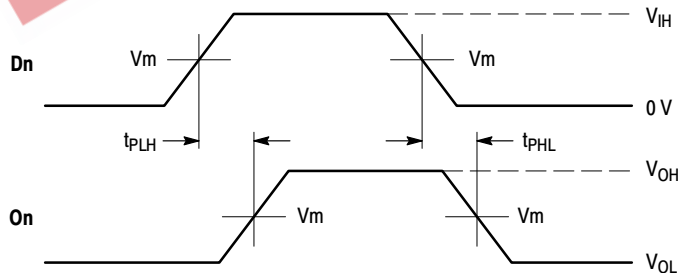

**WAVEFORM 1 - PROPAGATION DELAYS**  
 $t_R = t_F = 2.0$  ns, 10% to 90%;  $f = 1$  MHz;  $t_W = 500$  ns

**Figure 4. AC Waveforms**

# 74ALVCH16373

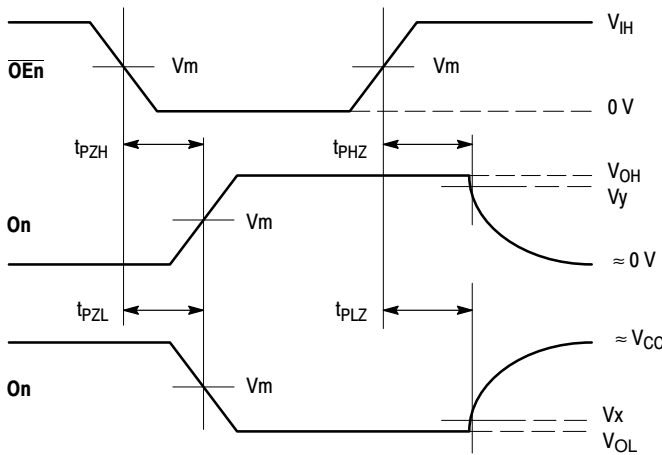

**WAVEFORM 2 - OUTPUT ENABLE AND DISABLE TIMES**

$t_R = t_F = 2.0$  ns, 10% to 90%;  $f = 1$  MHz;  $t_W = 500$  ns

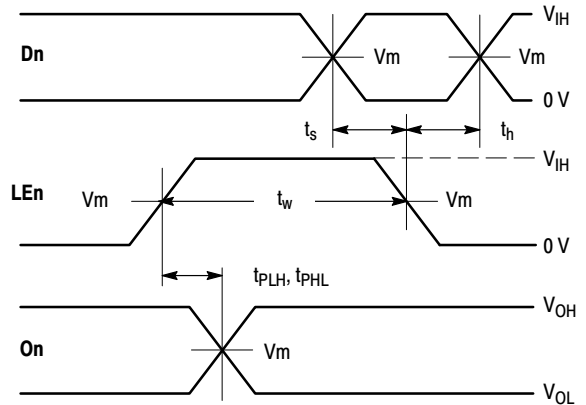

**WAVEFORM 3 - LE to On PROPAGATION DELAYS, LE MINIMUM PULSE WIDTH, Dn to LE SETUP AND HOLD TIMES**

$t_R = t_F = 2.0$  ns, 10% to 90%;  $f = 1$  MHz;  $t_W = 500$  ns except when noted

**Figure 5. AC Waveforms**

Symbol	$V_{CC}$		
	3.3 V $\pm$ 0.3 V	2.5 V $\pm$ 0.2 V	1.8 V $\pm$ 0.15 V
$V_{IH}$	2.7 V	$V_{CC}$	$V_{CC}$
$V_m$	1.5 V	$V_{CC}/2$	$V_{CC}/2$
$V_x$	$V_{OL} + 0.3$ V	$V_{OL} + 0.15$ V	$V_{OL} + 0.15$ V
$V_y$	$V_{OH} - 0.3$ V	$V_{OH} - 0.15$ V	$V_{OH} - 0.15$ V

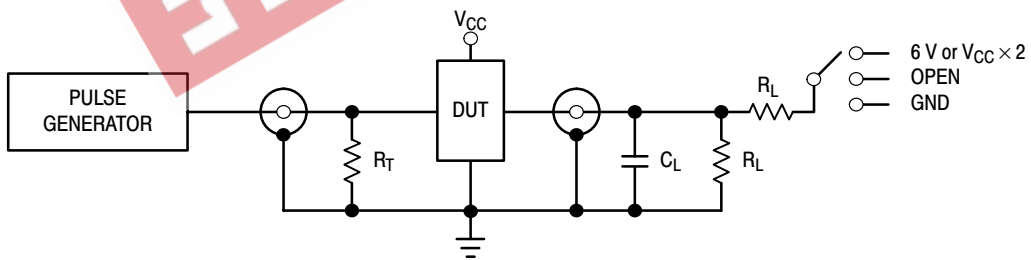

TEST	SWITCH
$t_{PLH}, t_{PHL}$	Open
$t_{PZL}, t_{PLZ}$	6 V at $V_{CC} = 3.3 \pm 0.3$ V; $V_{CC} \times 2$ at $V_{CC} = 2.5 \pm 0.2$ V; 1.8 V $\pm$ 0.15 V
$t_{PZH}, t_{PHZ}$	GND

$C_L = 50$  pF for  $V_{CC} = 3.0 \pm 0.3$  V

$R_L = 500 \Omega$  or equivalent

$R_T = Z_{OUT}$  of pulse generator (typically 50  $\Omega$ )

**Figure 6. Test Circuit**



# 74ALVCH16373

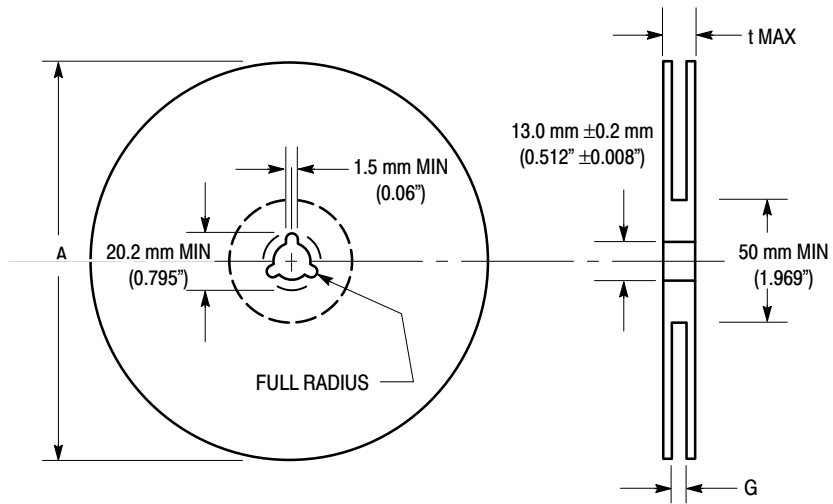

Figure 8. Reel Dimensions

## REEL DIMENSIONS

Tape Size	A Max	G	t Max
24 mm	360 mm (14.173")	24.4 mm + 2.0 mm, -0.0 (0.961" + 0.078", -0.00)	30.4 mm (1.197")

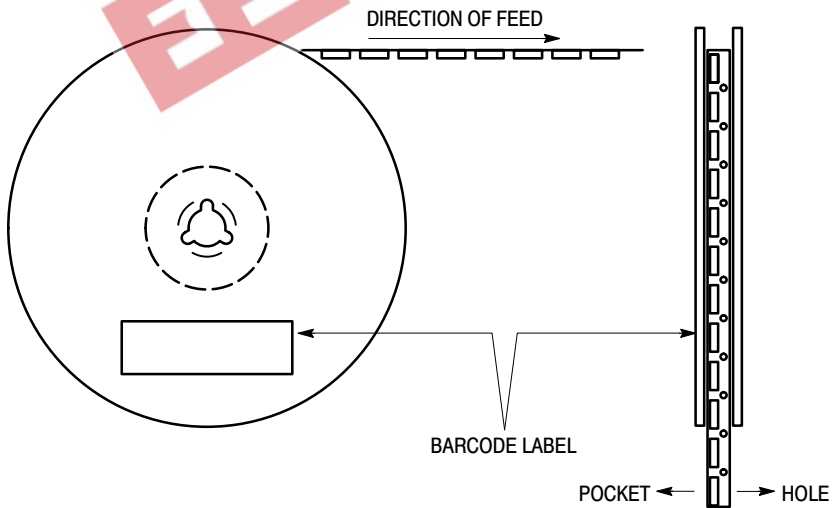

Figure 9. Reel Winding Direction



# 74ALVCH16373

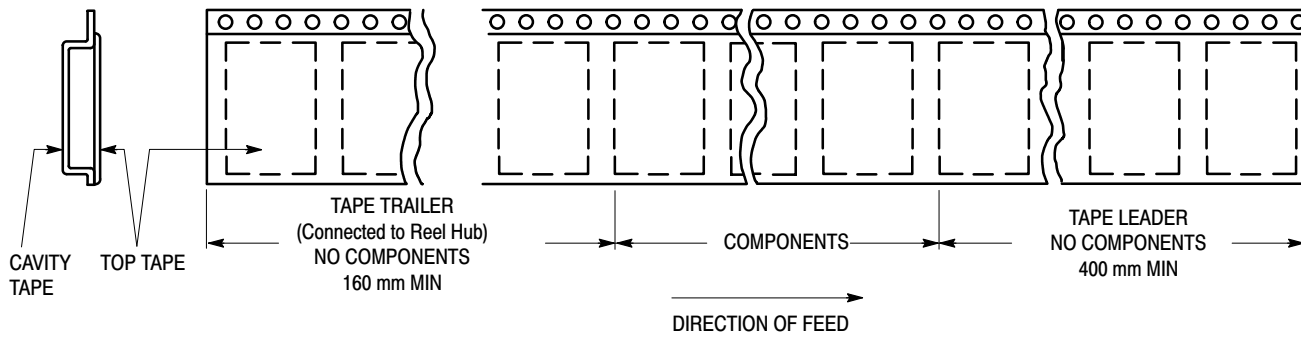

Figure 10. Tape Ends for Finished Goods

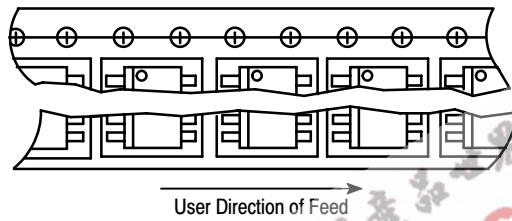

Figure 11. Reel Configuration

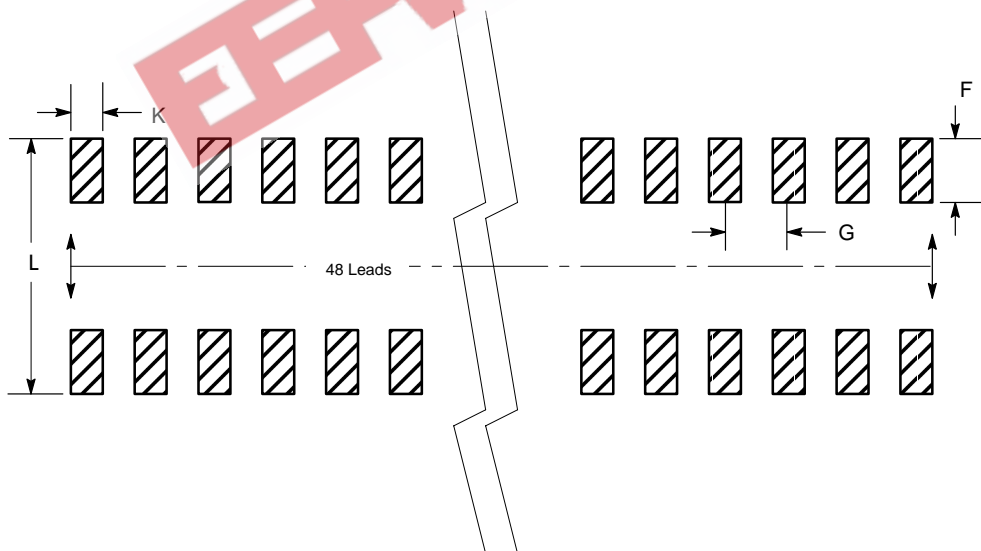
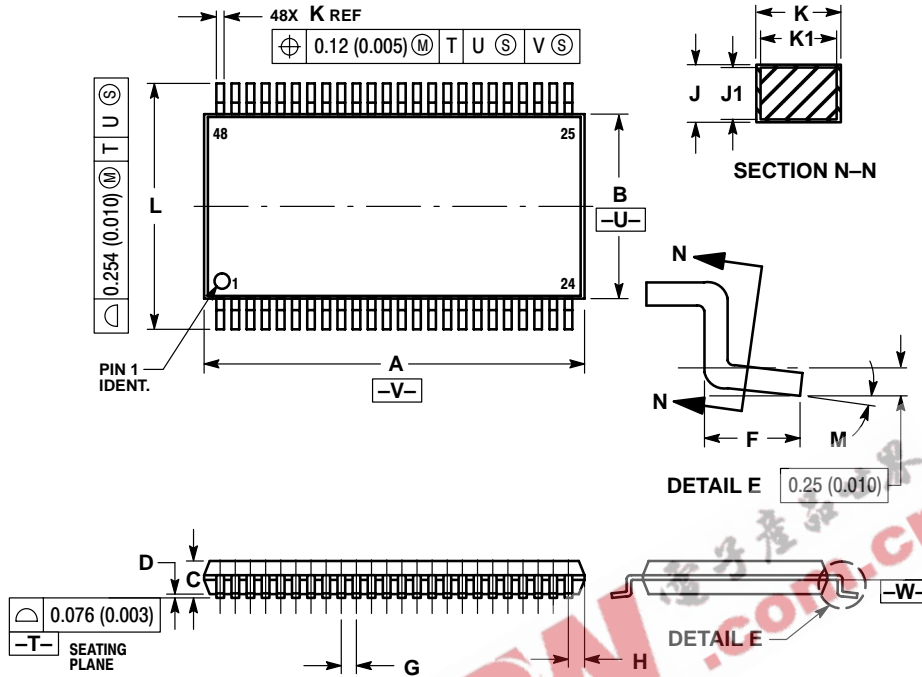

Figure 12. Package Footprint

# 74ALVCH16373

## PACKAGE DIMENSIONS

TSSOP  
DT SUFFIX  
CASE 1201-01  
ISSUE A



**NOTES:**

1. DIMENSIONING AND TOLERANCING PER ANSI Y14.5M, 1982.
2. CONTROLLING DIMENSION: MILLIMETER.
3. DIMENSIONS A AND B DO NOT INCLUDE MOLD FLASH, PROTRUSIONS OR GATE BURRS. MOLD FLASH OR GATE BURRS SHALL NOT EXCEED 0.15 (0.006) PER SIDE.
4. DIMENSION K DOES NOT INCLUDE DAMBAR PROTRUSION. ALLOWABLE DAMBAR PROTRUSION SHALL BE 0.08 (0.003) TOTAL IN EXCESS OF THE K DIMENSION AT MAXIMUM MATERIAL CONDITION.
5. TERMINAL NUMBERS ARE SHOWN FOR REFERENCE ONLY.
6. DIMENSIONS A AND B ARE TO BE DETERMINED AT DATUM PLANE -W-.

DIM	MILLIMETERS		INCHES	
	MIN	MAX	MIN	MAX
A	12.40	12.60	0.488	0.496
B	6.00	6.20	0.236	0.244
C	---	1.10	---	0.043
D	0.05	0.15	0.002	0.006
F	0.50	0.75	0.020	0.030
G	0.50 BSC		0.0197 BSC	
H	0.37	---	0.015	---
J	0.09	0.20	0.004	0.008
J1	0.09	0.16	0.004	0.006
K	0.17	0.27	0.007	0.011
K1	0.17	0.23	0.007	0.009
L	7.95	8.25	0.313	0.325
M	0°	8°	0°	8°

**Notes**

EEPW 电子产品世界  
.com.cn

74ALVCH16373

EEPW 电子產品世界  
.com.cn

**ON Semiconductor** and  are registered trademarks of Semiconductor Components Industries, LLC (SCILLC). SCILLC reserves the right to make changes without further notice to any products herein. SCILLC makes no warranty, representation or guarantee regarding the suitability of its products for any particular purpose, nor does SCILLC assume any liability arising out of the application or use of any product or circuit, and specifically disclaims any and all liability, including without limitation special, consequential or incidental damages. "Typical" parameters which may be provided in SCILLC data sheets and/or specifications can and do vary in different applications and actual performance may vary over time. All operating parameters, including "Typicals" must be validated for each customer application by customer's technical experts. SCILLC does not convey any license under its patent rights nor the rights of others. SCILLC products are not designed, intended, or authorized for use as components in systems intended for surgical implant into the body, or other applications intended to support or sustain life, or for any other application in which the failure of the SCILLC product could create a situation where personal injury or death may occur. Should Buyer purchase or use SCILLC products for any such unintended or unauthorized application, Buyer shall indemnify and hold SCILLC and its officers, employees, subsidiaries, affiliates, and distributors harmless against all claims, costs, damages, and expenses, and reasonable attorney fees arising out of, directly or indirectly, any claim of personal injury or death associated with such unintended or unauthorized use, even if such claim alleges that SCILLC was negligent regarding the design or manufacture of the part. SCILLC is an Equal Opportunity/Affirmative Action Employer.

#### PUBLICATION ORDERING INFORMATION

**Literature Fulfillment:**

Literature Distribution Center for ON Semiconductor  
P.O. Box 5163, Denver, Colorado 80217 USA  
**Phone:** 303-675-2175 or 800-344-3860 Toll Free USA/Canada  
**Fax:** 303-675-2176 or 800-344-3867 Toll Free USA/Canada  
**Email:** ONlit@hibbertco.com

**N. American Technical Support:** 800-282-9855 Toll Free USA/Canada

**JAPAN:** ON Semiconductor, Japan Customer Focus Center  
2-9-1 Kamimeguro, Meguro-ku, Tokyo, Japan 153-0051  
**Phone:** 81-3-5773-3850  
**Email:** r14525@onsemi.com

**ON Semiconductor Website:** <http://onsemi.com>

For additional information, please contact your local Sales Representative.

74ALVCH16373/D