

HD74LS251 • 1 of 8 Data Selectors/Multiplexers(with strobe and three-state outputs)

This data selector/multiplexer contains full on-chip binary decoding to select one-of-eight data sources and features a strobe-controlled 3-state output.

The strobe must be at a low logic level to enable this device. The 3-state outputs permit a number of outputs to be connected to a common bus.

When the strobe input is high, both outputs are in a high-impedance state in which both the upper and lower transistors of each totem-pole output are off, and the output neither drives nor loads the bus significantly. When the strobe is low, the outputs are activated and operate as standard TTL totem-pole outputs.

To minimize the possibility that two outputs will attempt to take a common bus to opposite logic levels, the output control circuitry is designed so that the average output disable time is shorter than the average output enable time.

■ BLOCK DIAGRAM

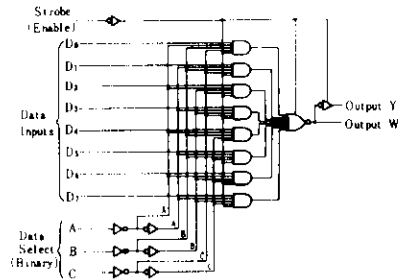

■ PIN ARRANGEMENT

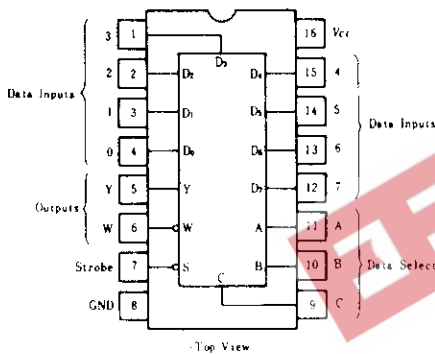

■ ABSOLUTE MAXIMUM RATINGS

Item	Symbol	Ratings	Unit
Supply voltage	V_{CC}	7.0	V
Input voltage	V_{IN}	7.0	V
Output voltage (off-state)	$V_{O(off)}$	5.5	V
Operating temperature range	T_{opr}	-20 ~ +75	°C
Storage temperature range	T_{stg}	-65 ~ +150	°C

■ FUNCTION TABLE

Inputs				Outputs	
SELECT			STROBE	Y	W
C	B	A	S		
X	X	X	H	Z	Z
L	L	L	L	$\overline{D_0}$	$\overline{D_0}$
L	L	H	L	$\overline{D_1}$	$\overline{D_1}$
L	H	L	L	$\overline{D_2}$	$\overline{D_2}$
L	H	H	L	$\overline{D_3}$	$\overline{D_3}$
H	L	L	L	$\overline{D_4}$	$\overline{D_4}$
H	L	H	L	$\overline{D_5}$	$\overline{D_5}$
H	H	L	L	$\overline{D_6}$	$\overline{D_6}$
H	H	H	L	$\overline{D_7}$	$\overline{D_7}$

- Notes) 1. H; high level, L; low level, X; irrelevant
 2. Z; high impedance (off-state)
 3. $\overline{D_0}$ through $\overline{D_7}$; the level of the respective D input.

■ ELECTRICAL CHARACTERISTICS ($T_a = -20 \sim +75^\circ\text{C}$)

Item	Symbol	Test Conditions	min	typ*	max	Unit	
Input voltage	V_{IH}		2.0	—	—	V	
	V_{IL}		—	—	0.8	V	
Output voltage	V_{OH}	$V_{CC}=4.75\text{V}, V_{IH}=2\text{V}, V_{IL}=0.8\text{V}, I_{OH}=-2.6\text{mA}$	2.4	—	—	V	
	V_{OL}	$V_{CC}=4.75\text{V}, V_{IH}=2\text{V}, V_{IL}=0.8\text{V}$	$I_{OL}=4\text{mA}$	—	—	0.4	V
			$I_{OL}=8\text{mA}$	—	—	0.5	V
Input current	I_{IH}	$V_{CC}=5.25\text{V}, V_I=2.7\text{V}$	—	—	20	μA	
	I_{IL}	$V_{CC}=5.25\text{V}, V_I=0.4\text{V}$	—	—	-0.4	mA	
	I_I	$V_{CC}=5.25\text{V}, V_I=7\text{V}$	—	—	0.1	mA	
Output current	I_{OZ}	$V_{CC}=5.25\text{V}, V_{IH}=2\text{V}$	$V_O=2.7\text{V}$	—	—	20	μA
			$V_O=0.4\text{V}$	—	—	-20	μA
Short-circuit output current	I_{OS}	$V_{CC}=5.25\text{V}$	-30	—	-130	mA	
Supply current**	I_{CC}	$V_{CC}=5.25\text{V}$	Condition A	—	6.1	10	mA
			Condition B	—	7.1	12	mA
Input clamp voltage	V_{IK}	$V_{CC}=4.75\text{V}, I_{IN}=-18\text{mA}$	—	—	-1.5	V	

* $V_{CC}=5\text{V}, T_a=25^\circ\text{C}$

** I_{CC} is measured with the outputs open and all data and select inputs at 4.5V under the following conditions:
 A. Strobe grounded, B. Strobe at 4.5V

HD74LS251

SWITCHING CHARACTERISTICS ($V_{CC}=5V$, $T_a=25^\circ C$)

Item	Inputs	Outputs	Symbol	Test Conditions	min	typ	max	Unit
Propagation delay time	A, B, C (4 level)	Y	t_{PLH}	$C_L = 15pF$ $R_L = 2k\Omega$	—	29	45	ns
			t_{PHL}		—	28	45	
	A, B, C (3 level)	W	t_{PLH}		—	20	33	
			t_{PHL}		—	21	33	
	Data	Y	t_{PLH}		—	17	28	
			t_{PHL}		—	18	28	
Data	W	t_{PLH}	—	10	15			
		t_{PHL}	—	9	15			
Output enable time	Strobe	Y	t_{ZH}	$C_L = 5pF$ $R_L = 2k\Omega$	—	30	45	ns
			t_{ZL}		—	26	40	
	Strobe	W	t_{ZH}		—	17	27	
			t_{ZL}		—	24	40	
Output disable time	Strobe	Y	t_{HZ}	$C_L = 5pF$ $R_L = 2k\Omega$	—	30	45	ns
			t_{LZ}		—	15	25	
	Strobe	W	t_{HZ}		—	37	55	
			t_{LZ}		—	15	25	

TESTING METHOD

1) Test Circuit

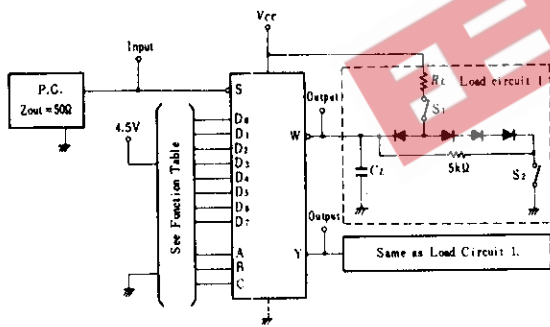

Waveform

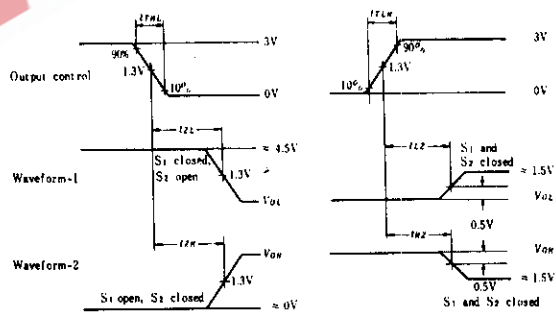

- Notes)
1. Input pulse: $t_{TLH} \leq 15ns$, $t_{THL} \leq 6ns$, $PRR=1MHz$, duty cycle = 50%.
 2. C_L includes probe and jig capacitance.
 3. All diodes are 1S2074 $\text{\textcircled{R}}$.
 4. Waveform-1 is for an output with internal conditions such that the output is low except when disabled by the output control.
 5. Waveform-2 is for an output with internal conditions such that the output is high except when disabled by the output control.

EEPW 电子产品世界 .com.cn

Unit: mm

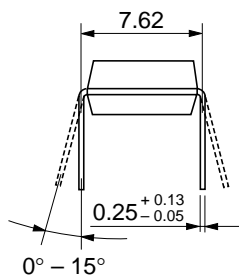
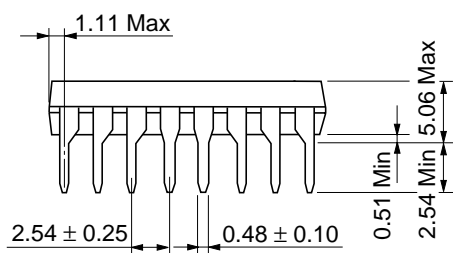
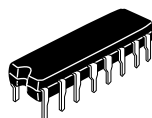
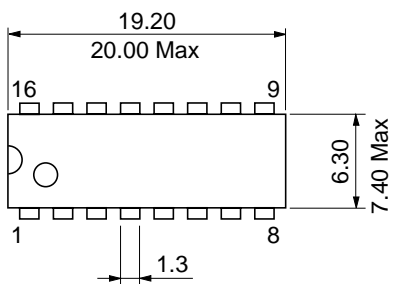

Hitachi Code	DP-16
JEDEC	Conforms
EIAJ	Conforms
Weight (reference value)	1.07 g

Unit: mm

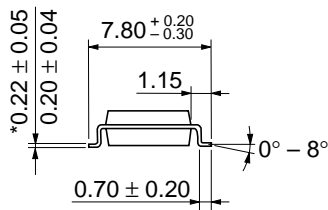
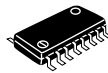
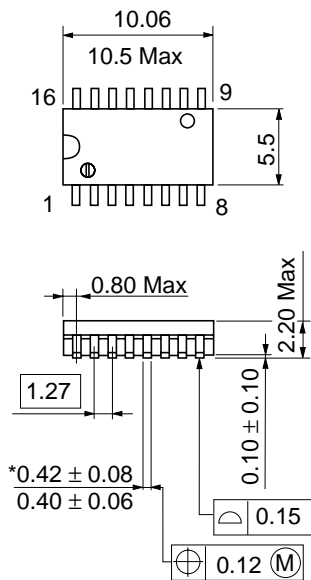

Hitachi Code	FP-16DA
JEDEC	—
EIAJ	Conforms
Weight (reference value)	0.24 g

*Dimension including the plating thickness
Base material dimension

Unit: mm

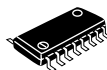
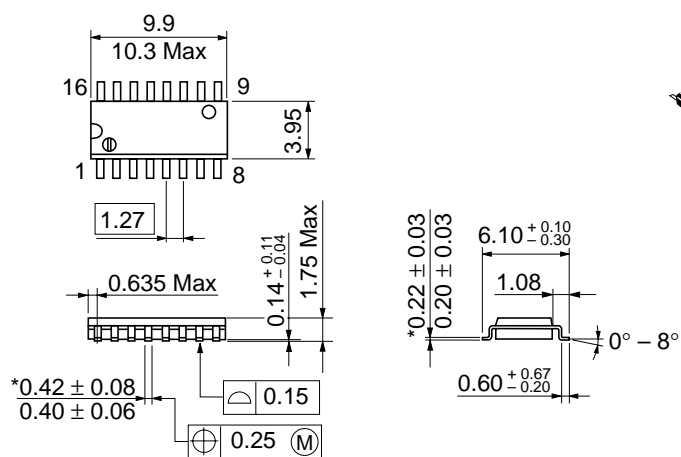

Hitachi Code	FP-16DN
JEDEC	Conforms
EIAJ	Conforms
Weight (reference value)	0.15 g

*Dimension including the plating thickness
Base material dimension

Cautions

1. Hitachi neither warrants nor grants licenses of any rights of Hitachi's or any third party's patent, copyright, trademark, or other intellectual property rights for information contained in this document. Hitachi bears no responsibility for problems that may arise with third party's rights, including intellectual property rights, in connection with use of the information contained in this document.
2. Products and product specifications may be subject to change without notice. Confirm that you have received the latest product standards or specifications before final design, purchase or use.
3. Hitachi makes every attempt to ensure that its products are of high quality and reliability. However, contact Hitachi's sales office before using the product in an application that demands especially high quality and reliability or where its failure or malfunction may directly threaten human life or cause risk of bodily injury, such as aerospace, aeronautics, nuclear power, combustion control, transportation, traffic, safety equipment or medical equipment for life support.
4. Design your application so that the product is used within the ranges guaranteed by Hitachi particularly for maximum rating, operating supply voltage range, heat radiation characteristics, installation conditions and other characteristics. Hitachi bears no responsibility for failure or damage when used beyond the guaranteed ranges. Even within the guaranteed ranges, consider normally foreseeable failure rates or failure modes in semiconductor devices and employ systemic measures such as fail-safes, so that the equipment incorporating Hitachi product does not cause bodily injury, fire or other consequential damage due to operation of the Hitachi product.
5. This product is not designed to be radiation resistant.
6. No one is permitted to reproduce or duplicate, in any form, the whole or part of this document without written approval from Hitachi.
7. Contact Hitachi's sales office for any questions regarding this document or Hitachi semiconductor products.

HITACHI

Hitachi, Ltd.

Semiconductor & Integrated Circuits.
Nippon Bldg., 2-6-2, Ohte-machi, Chiyoda-ku, Tokyo 100-0004, Japan
Tel: Tokyo (03) 3270-2111 Fax: (03) 3270-5109

URL North America : <http://semiconductor.hitachi.com/>
 Europe : <http://www.hitachi-eu.com/hel/ecg>
 Asia (Singapore) : <http://www.has.hitachi.com.sg/grp3/sicd/index.htm>
 Asia (Taiwan) : http://www.hitachi.com.tw/E/Product/SICD_Frame.htm
 Asia (HongKong) : <http://www.hitachi.com.hk/eng/bo/grp3/index.htm>
 Japan : <http://www.hitachi.co.jp/Sicd/indx.htm>

For further information write to:

Hitachi Semiconductor
(America) Inc.
179 East Tasman Drive,
San Jose, CA 95134
Tel: <1> (408) 433-1990
Fax: <1> (408) 433-0223

Hitachi Europe GmbH
Electronic components Group
Dornacher StraÙe 3
D-85622 Feldkirchen, Munich
Germany
Tel: <49> (89) 9 9180-0
Fax: <49> (89) 9 29 30 00

Hitachi Europe Ltd.
Electronic Components Group.
Whitebrook Park
Lower Cookham Road
Maidenhead
Berkshire SL6 8YA, United Kingdom
Tel: <44> (1628) 585000
Fax: <44> (1628) 778322

Hitachi Asia Pte. Ltd.
16 Collyer Quay #20-00
Hitachi Tower
Singapore 049318
Tel: 535-2100
Fax: 535-1533

Hitachi Asia Ltd.
Taipei Branch Office
3F, Hung Kuo Building, No.167,
Tun-Hwa North Road, Taipei (105)
Tel: <886> (2) 2718-3666
Fax: <886> (2) 2718-8180

Hitachi Asia (Hong Kong) Ltd.
Group III (Electronic Components)
7/F., North Tower, World Finance Centre,
Harbour City, Canton Road, Tsim Sha Tsui,
Kowloon, Hong Kong
Tel: <852> (2) 735 9218
Fax: <852> (2) 730 0281
Telex: 40815 HITEC HX

Copyright ' Hitachi, Ltd., 1999. All rights reserved. Printed in Japan.

HITACHI