

## ADC081000

# 8-Bit, 1 GSPS A/D Converter with Internal Reference and Sample-and-Hold

### General Description

**NOTE: This product is currently in development. - ALL specifications are design targets and are subject to change.**

The ADC081000 is a low power, high performance CMOS analog-to-digital converter that digitizes signals to 8 bits resolution at sampling rates up to 1.6 GSPS while consuming a typical 1.4 Watts from a single 1.9 Volt supply at 1.0 GSPS. This device is guaranteed to have no missing codes over the full operating temperature range. The unique folding/interpolating architecture, the fully differential comparator design and the innovative design of the internal sample-and-hold amplifier enable a very flat SINAD/ENOB response beyond Nyquist, producing a high 7.5 ENOB with a 100 MHz input signal and a 1 GHz sample rate. Output formatting is offset binary coding with LVDS digital outputs compliant with IEEE 1596.3-1996, with the exception of a reduced common mode voltage of 0.8V.

The converter has a 1:2 demultiplexer that feeds two LVDS buses and reduces the output data rate on each bus to half the sampling rate. The data on these buses are interleaved in time to provide a 500 MSPS output rate per bus and a combined output rate of 1 GSPS.

Setting the PD (Power Down) pin high places the converter into an inactive power down state, where it typically consumes less than 5 mW.

The ADC081000 is available in a 128-lead exposed pad LQFP and operates over the industrial ( $-40^{\circ}\text{C} \leq T_A \leq +85^{\circ}\text{C}$ ) temperature range.

### Features

- Internal Sample-and-Hold
- Single +1.9V  $\pm 0.1\text{V}$  Operation
- Adjustable Output Levels
- Guaranteed No Missing Codes
- Low Power Standby Mode

### Key Specifications

■ Resolution	8 Bits
■ Max Conversion Rate	1 GSPS (min) Guaranteed
■ No Missing Codes	7.5 Bits (typ)
■ ENOB @ 100 MHz Input	$\pm 0.25$ LSB (typ)
■ DNL	7/8 Clock Cycles
■ Conversion Latency	40 dB (typ)
■ PSRR	1.4 W (typ)
■ Power Consumption	5 mW (typ)
— Operating	
— Power Down Mode	

### Applications

- Direct RF Down Conversion
- Digital Oscilloscopes
- RADAR / SONAR / ECM
- Satellite Set-top boxes
- WLANs
- Communications Systems
- Test Instrumentation

### Block Diagram

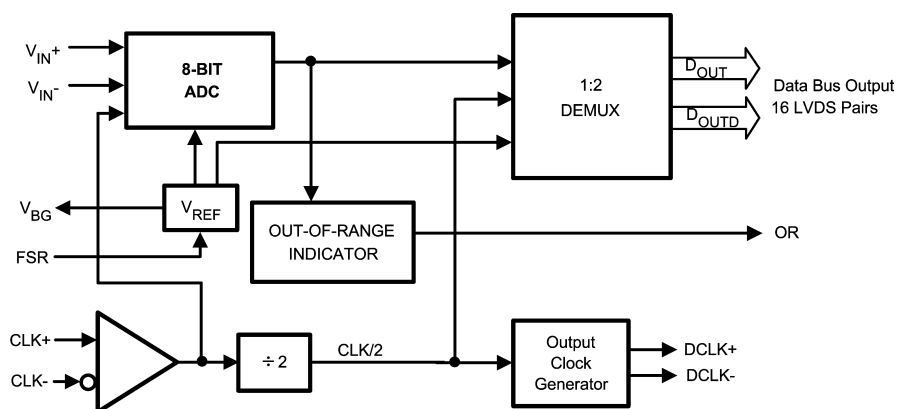

20068153

## Ordering Information

Extended Commercial Temperature Range (-40°C < T <sub>A</sub> < +85°C)	NS Package
ADC081000CIYB	128-Pin Exposed Pad LQFP
ADC081000LEVAL	Evaluation Board

## Pin Configuration

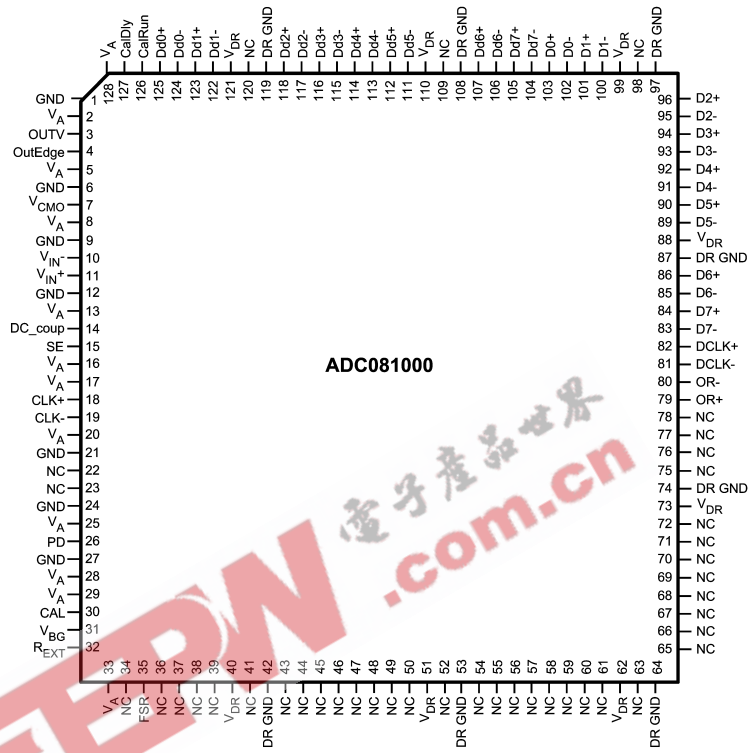

20068101

**Physical Dimensions** inches (millimeters) unless otherwise noted

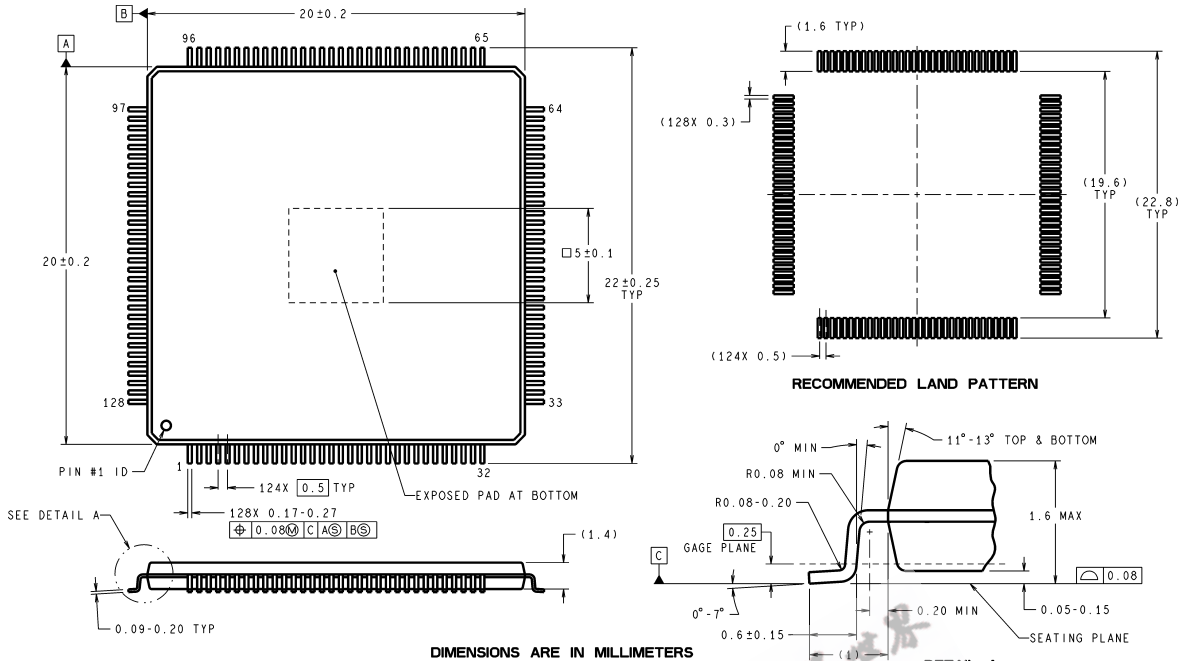

DIMENSIONS ARE IN MILLIMETERS

DETAIL A  
TYPICAL

VNX128A (Rev A)

NOTES: UNLESS OTHERWISE SPECIFIED  
REFERENCE JEDEC REGISTRATION MS-026, VARIATION BFB.

**24-Lead Package TC**  
**Order Number ADC081000CJMT**  
**NS Package Number VNX128A**

**LIFE SUPPORT POLICY**

NATIONAL'S PRODUCTS ARE NOT AUTHORIZED FOR USE AS CRITICAL COMPONENTS IN LIFE SUPPORT DEVICES OR SYSTEMS WITHOUT THE EXPRESS WRITTEN APPROVAL OF THE PRESIDENT AND GENERAL COUNSEL OF NATIONAL SEMICONDUCTOR CORPORATION. As used herein:

1. Life support devices or systems are devices or systems which, (a) are intended for surgical implant into the body, or (b) support or sustain life, and whose failure to perform when properly used in accordance with instructions for use provided in the labeling, can be reasonably expected to result in a significant injury to the user.
2. A critical component is any component of a life support device or system whose failure to perform can be reasonably expected to cause the failure of the life support device or system, or to affect its safety or effectiveness.

**BANNED SUBSTANCE COMPLIANCE**

National Semiconductor certifies that the products and packing materials meet the provisions of the Customer Products Stewardship Specification (CSP-9-111C2) and the Banned Substances and Materials of Interest Specification (CSP-9-111S2) and contain no "Banned Substances" as defined in CSP-9-111S2.



**National Semiconductor**  
**Americas Customer Support Center**  
Email: new.feedback@nsc.com  
Tel: 1-800-272-9959

**National Semiconductor**  
**Europe Customer Support Center**  
Fax: +49 (0) 180-530 85 86  
Email: europe.support@nsc.com  
Deutsch Tel: +49 (0) 69 9508 6208  
English Tel: +44 (0) 870 24 0 2171  
Français Tel: +33 (0) 1 41 91 8790

**National Semiconductor**  
**Asia Pacific Customer Support Center**  
Email: ap.support@nsc.com

**National Semiconductor**  
**Japan Customer Support Center**  
Fax: 81-3-5639-7507  
Email: jpn.feedback@nsc.com  
Tel: 81-3-5639-7560

www.national.com