

DATA SHEET

74F723A

Quad 2-to-1 data selector multiplexer
(3-State)

74F723-1

Quad 2-to-1 data selector multiplexer
with 30Ω equivalent output termination
impedance (3-State)

74F725A

Quad 3-to-1 data selector multiplexer
(3-State)

74F725-1

Quad 3-to-1 data selector multiplexer
with 30Ω equivalent output termination
impedance (3-State)

Product specification

1990 Dec 13

IC15 Data Handbook

Multiplexers

74F723A/74F723-1/ 74F725A/74F725-1

74F723A Quad 3-to-1 Data Selector Multiplexer (3-State)

74F723-1 Quad 3-to-1 Data Selector Multiplexer with 30Ω Equivalent Output Termination Impedance (3-State)

74F725A Quad 4-to-1 Data Selector Multiplexer

74F725-1 Quad 4-to-1 Data Selector Multiplexer with 30Ω Equivalent Output Termination Impedance

FEATURES for 74F723A/74F723-1

- Consists of four 3-to-1 Multiplexers
- High impedance PNP base inputs for reduced loading (20μA in High and Low states)
- Inverting or non-inverting data path capability by an inverting ($\overline{\text{INV}}$) input
- Designed for address multiplexing of dynamic RAM and other applications
- Multiple side pins for V_{CC} and GND to reduce lead inductance (improves speed and noise immunity)
- 3-State outputs sink 64mA (74F723A only)
- 30Ω termination impedance on each output – 74F723-1

FEATURES for 74F725A/74F725-1

- Consists of four 4-to-1 Multiplexers
- High impedance PNP base inputs for reduced loading (20μA in High and Low states)
- Equivalent to two 74F253s without 3-State
- Outputs sink 64mA (74F725A only)
- 30Ω termination impedance on each output – 74F725-1

DESCRIPTION

The 74F723A/74F723-1 consist of four 3-to-1 multiplexers designed for address multiplexing of dynamic RAMs and other multiplexing applications. Select (S0, S1) inputs control which line is to be selected, as defined in the Function Table for 74F723A/74F723-1. When the inverting input ($\overline{\text{INV}}$) is Low, the input data path is inverted.

To improve speed and noise immunity, V_{CC} and GND side pins are used. The 3-State outputs source 15mA and sink 64mA. The

74F723-1 is the same as 74F723A except that it has a 30Ω termination impedance on each output to reduce line noise and the 3-State outputs sink 5mA.

The 74F725A/74F725-1 consist of four 4-to-1 multiplexers designed for general multiplexing purpose. The select (S0, S1) inputs control which line is to be selected, as defined in the Function Table for 74F725A/725-1. The outputs source 15mA and sink 64mA. The 74F725-1 is the same as the 74F725A except that it has a 30Ω termination impedance on each output to reduce line noise and the outputs sink 5mA.

TYPE	TYPICAL PROPAGATION DELAY	TYPICAL SUPPLY CURRENT (TOTAL)
74F723A	5.5ns	25mA
74F723-1	7.0ns	26mA
74F725A	5.5ns	20mA
74F725-1	6.5ns	20mA

ORDERING INFORMATION

DESCRIPTION	COMMERCIAL RANGE $V_{\text{CC}} = 5V \pm 10\%$ $T_{\text{amb}} = 0^{\circ}\text{C to } +70^{\circ}\text{C}$	PKG DWG #
20-Pin Plastic Slim DIP (300 mil)	N74F723AN, N74F723-1N, N74F725AN, N74F725-1N	SOT222-1
24-Pin Plastic SOL	N74F723AD, N74F723-1D, N74F725AD, N74F725-1D	SOT137-1

INPUT AND OUTPUT LOADING AND FAN-OUT TABLE

TYPE	PINS	DESCRIPTION	74F(U.L.) HIGH/LOW	LOAD VALUE HIGH/LOW
74F723A/ 74F723-1	Dna, Dnb, Dnc	Data inputs	1.0/0.066	20μA/40μA
	S0, S1	Select inputs	1.0/0.033	20μA/20μA
	$\overline{\text{OE}}$	Output Enable input	1.0/0.033	20μA/20μA
	$\overline{\text{INV}}$	Output inverting input	1.0/0.033	20μA/20μA
74F723A	Q0 - Q3	Data outputs for 74F723A	750/106.7	15mA/64mA
74F723-1	Q0 - Q3	Data outputs for 74F723-1	750/8.33	15mA/5mA
74F725A/ 74F725-1	Dna, Dnb, Dnc, Dnd	Data inputs	1.0/0.066	20μA/40μA
	S0, S1	Select inputs	1.0/0.033	20μA/20μA
74F725A	Q0 - Q3	Data outputs	750/106.7	15mA/64mA
74F725-1	Q0 - Q3	Data outputs	750/8.33	15mA/5mA

NOTE: One (1.0) FAST Unit Load (U.L.) is defined as: 20μA in the High state and 0.6mA in the Low state.

Multiplexers

74F723A/74F723-1/ 74F725A/74F725-1

PIN CONFIGURATION – 74F723A/74F723-1

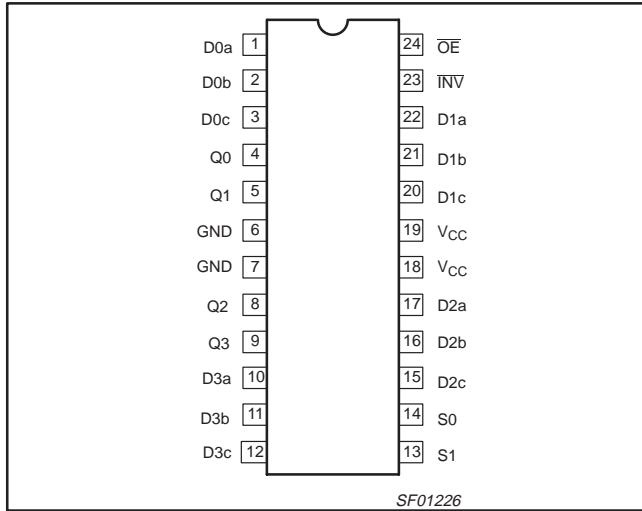

PIN CONFIGURATION – 74F725A/74F725-1

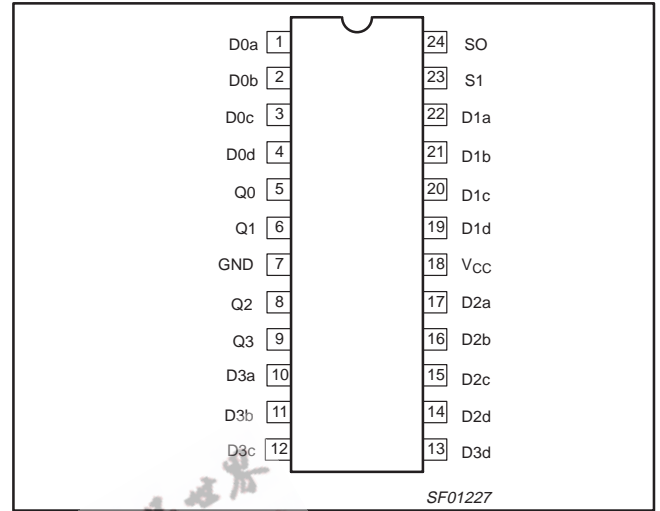

LOGIC SYMBOL – 74F723A/74F723-1

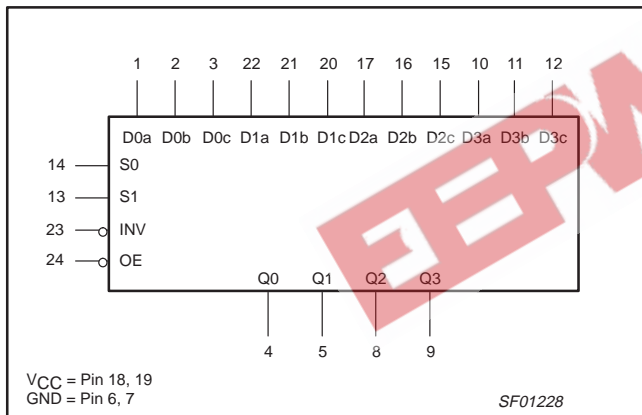

LOGIC SYMBOL – 74F725A/74F725-1

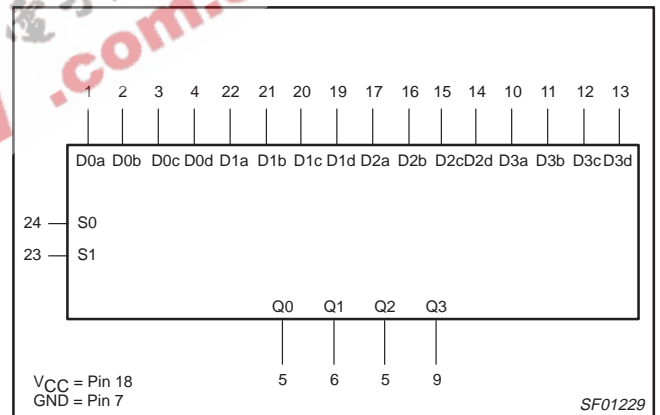

LOGIC SYMBOL (IEEE/IEC) – 74F723A/74F723-1

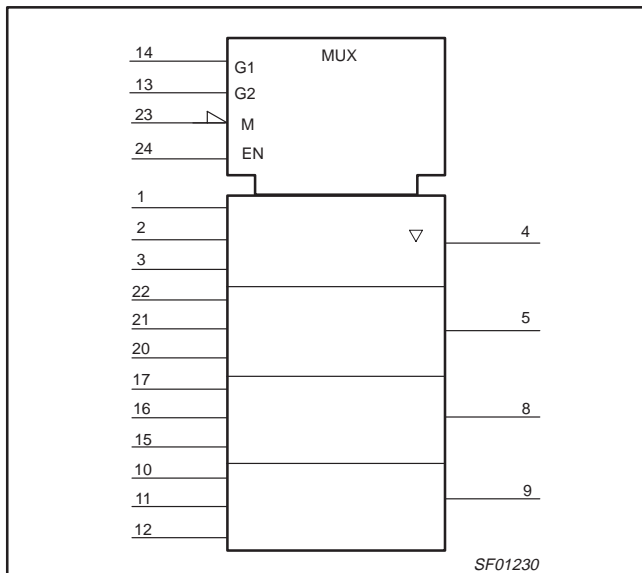

LOGIC SYMBOL (IEEE/IEC) – 74F725A/74F725-1

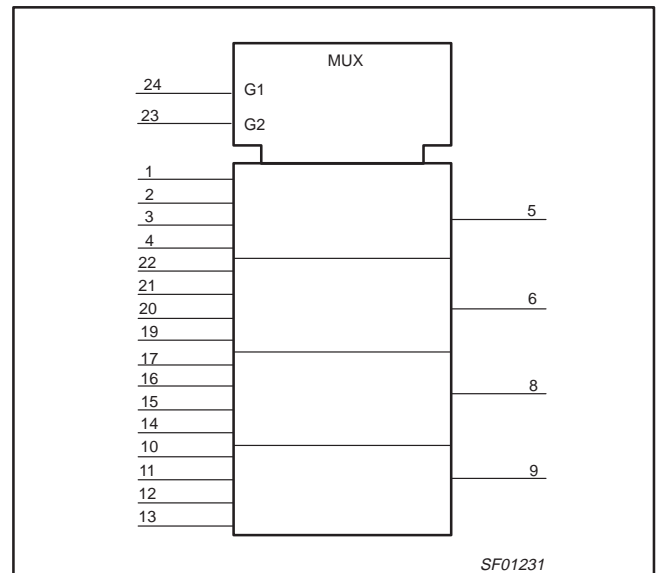

Multiplexers

74F723A/74F723-1/
74F725A/74F725-1

LOGIC DIAGRAM – 74F723A/74F723-1

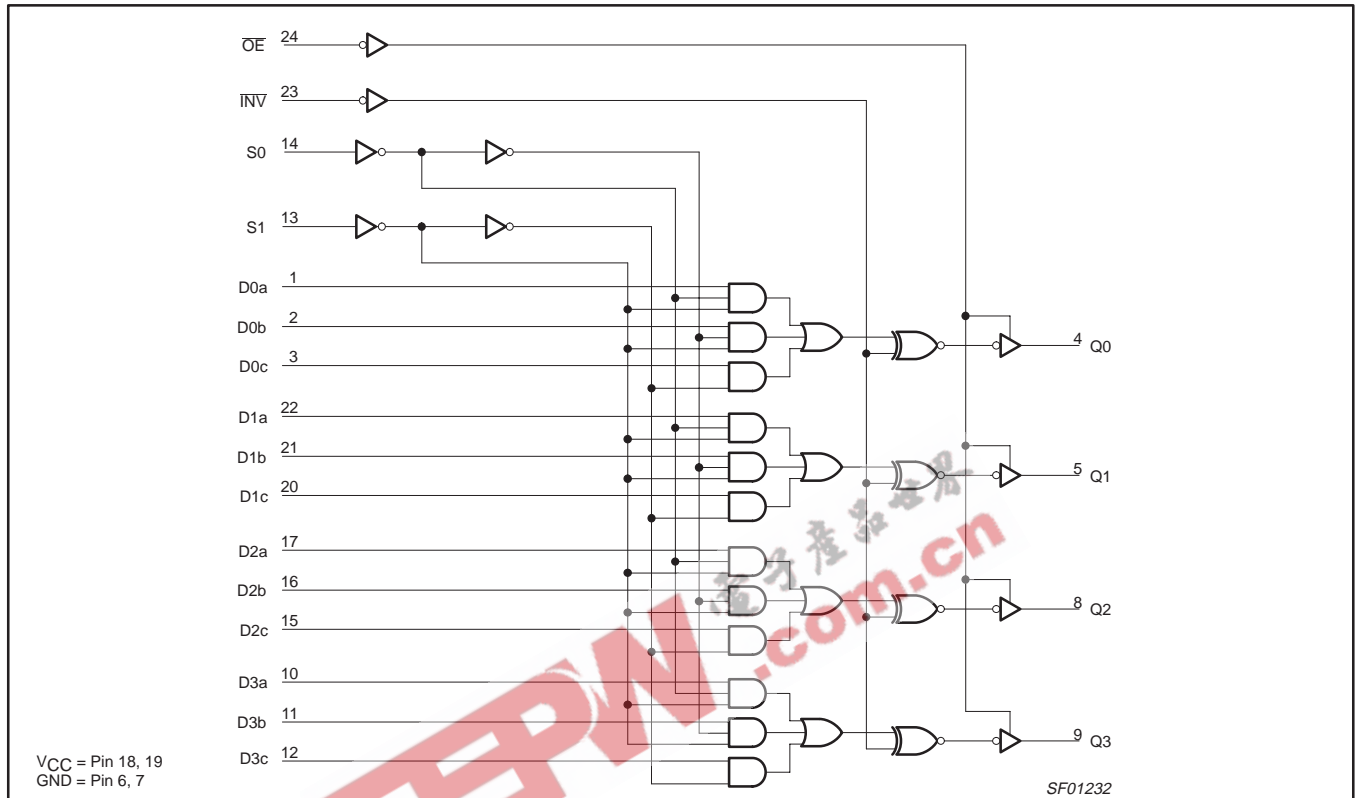

FUNCTION TABLE – 74F723A/74F723-1

INPUTS							OUTPUT
S0	S1	INV	OE	Dna	Dnb	Dnc	Qn
L	L	L	L	Data a	Data b	Data c	$\overline{\text{Data a}}$
L	L	H	L	Data a	Data b	Data c	Data a
H	L	L	L	Data a	Data b	Data c	$\overline{\text{Data b}}$
H	L	H	L	Data a	Data b	Data c	Data b
X	H	L	L	Data a	Data b	Data c	$\overline{\text{Data c}}$
X	H	H	L	Data a	Data b	Data c	Data c
X	X	X	H	X	X	X	Z

H = High voltage level
L = Low voltage level
X = Don't care
Z = High impedance "off" state

Multiplexers

74F723A/74F723-1/
74F725A/74F725-1

LOGIC DIAGRAM – 74F725A/74F725-1

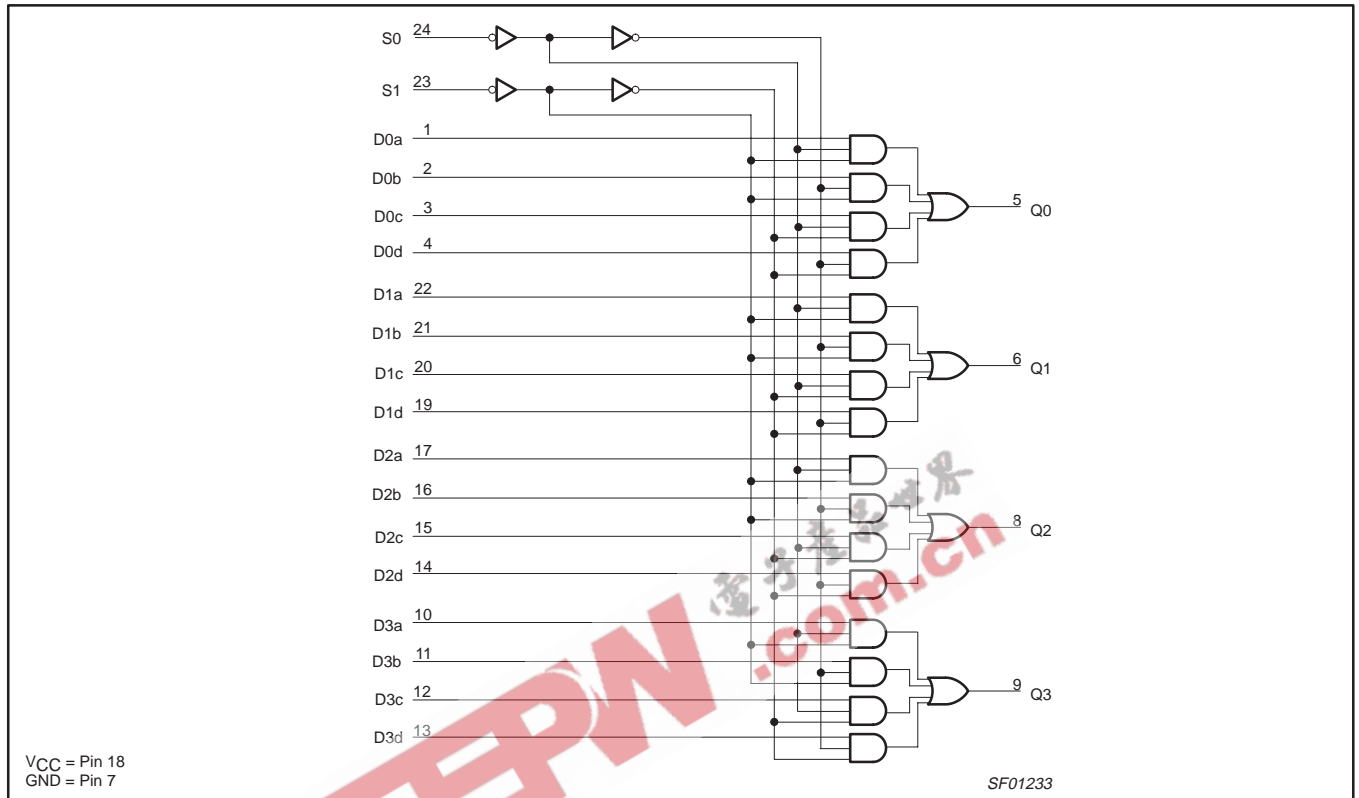

FUNCTION TABLE – 74F725A/74F725-1

INPUTS						OUTPUT
S0	S1	Dna	Dnb	Dnc	Dnd	Qn
L	L	Data a	Data b	Data c	Data d	Data a
H	L	Data a	Data b	Data c	Data d	Data b
L	H	Data a	Data b	Data c	Data d	Data c
H	H	Data a	Data b	Data c	Data d	Data d

H = High voltage level
L = Low voltage level

Multiplexers

74F723A/74F723-1/
74F725A/74F725-1**ABSOLUTE MAXIMUM RATINGS**

Operation beyond the limits set forth in this table may impair the useful life of the device.
Unless otherwise noted these limits are over the operating free-air temperature range.

SYMBOL	PARAMETER		RATING	UNIT
V _{CC}	Supply voltage		-0.5 to +7.0	V
V _{IN}	Input voltage		-0.5 to +7.0	V
I _{IN}	Input current		-30 to +5	mA
V _{OUT}	Voltage applied to output in High output state		-0.5 to +V _{CC}	V
I _{OUT}	Current applied to output in Low output state	74F723-1, 74F725-1	10	mA
		74F723A, 74F725A	96	mA
T _{amb}	Operating free-air temperature range		0 to +70	°C
T _{stg}	Storage temperature		-65 to +150	°C

RECOMMENDED OPERATING CONDITIONS

SYMBOL	PARAMETER	LIMITS			UNIT
		MIN	NOM	MAX	
V _{CC}	Supply voltage	4.5	5.0	5.5	V
V _{IH}	High-level input voltage	2.0			V
V _{IL}	Low-level input voltage			0.8	V
I _{IK}	Input clamp current			-18	mA
I _{OH}	High-level output current			-15	mA
I _{OL}	Low-level output current	74F723-1, 74F725-1		5	mA
		74F723A, 74F725A		64	mA
T _{amb}	Operating free-air temperature	0		70	°C

Multiplexers

74F723A/74F723-1/
74F725A/74F725-1

DC ELECTRICAL CHARACTERISTICS

(Over recommended operating free-air temperature range unless otherwise noted.)

SYMBOL	PARAMETER		TEST CONDITIONS ^{NO TAG}			LIMITS			UNIT	
						MIN	TYP NO TAG	MAX		
V _{OH}	High-level output voltage		V _{CC} = MIN, V _{IL} = MAX, V _{IH} = MIN	I _{OH} = -3mA	±10%V _{CC}	2.4			V	
					±5%V _{CC}	2.7	3.4		V	
				I _{OH} = -15mA	±10%V _{CC}	2.0			V	
					±5%V _{CC}	2.0			V	
V _{OL}	Low-level output voltage	74F723-1/ 74F725-1	V _{CC} = MIN, V _{IL} = MAX, V _{IH} = MIN	I _{OL} = 5mA	±10%V _{CC}		0.38	0.50	V	
					±5%V _{CC}		0.38	0.50	V	
		74F723A/ 74F725A		I _{OL} = MAX	±10%V _{CC}		0.38	0.55	V	
					±5%V _{CC}		0.42	0.55	V	
V _{IK}	Input clamp voltage		V _{CC} = MIN, I _I = I _{IK}			-0.73	-1.2	V		
I _I	Input current at maximum input voltage		V _{CC} = MAX, V _I = 7.0V				100	μA		
I _{IH}	High-level input current		V _{CC} = MAX, V _I = 2.7V				20	μA		
I _{IL}	Low-level input current	Others	V _{CC} = MAX, V _I = 0.5V				-20	μA		
		Dn only					-40	μA		
I _{OZH}	Off-state output current High-level voltage applied	74F723A/ 74F723-1 only	V _{CC} = MAX, V _O = 2.7V				50	μA		
I _{OZL}	Off-state output current Low-level voltage applied		V _{CC} = MAX, V _O = 0.5V				-50	μA		
I _{OS}	Short-circuit output current ³	74F723-1/ 74F725-1	V _{CC} = MAX			-60	-150	mA		
I _O	Output current ^{NO TAG}	74F723A/ 74F725A	V _{CC} = MAX, V _O = 2.25V			-60	-150	mA		
I _{CC}	Supply current (total)	74F723A	I _{CCH}	V _{CC} = MAX				23	30	mA
			I _{CCL}					29	40	mA
			I _{CCZ}					25	40	mA
		74F723-1	I _{CCH}	V _{CC} = MAX				23	35	mA
			I _{CCL}					29	40	mA
			I _{CCZ}					26	40	mA
		74F725A	I _{CCH}	V _{CC} = MAX				16	25	mA
			I _{CCL}					24	35	mA
		74F725-1	I _{CCH}	V _{CC} = MAX				17	25	mA
			I _{CCL}					25	35	mA

NOTES:

- For conditions shown as MIN or MAX, use the appropriate value specified under recommended operating conditions for the applicable type.
- All typical values are at V_{CC} = 5V, T_{amb} = 25°C.
- Not more than one output should be shorted at a time. For testing I_{OS}, the use of high-speed test apparatus and/or sample-and-hold techniques are preferable in order to minimize internal heating and more accurately reflect operational values. Otherwise, prolonged shorting of a High output may raise the chip temperature well above normal and thereby cause invalid readings in other parameter tests. In any sequence of parameter tests, I_{OS} tests should be performed last.
- I_O is tested under conditions that produce current approximately one half of the true short-circuit output current (I_{OS}).

Multiplexers

74F723A/74F723-1/
74F725A/74F725-1

AC ELECTRICAL CHARACTERISTICS – 74F723A/74F723-1

SYMBOL	PARAMETER		TEST CONDITION	LIMITS					UNIT
				T _{amb} = +25°C V _{CC} = 5V C _L = 50pF, R _L = 500Ω			T _{amb} = 0° C to +70°C V _{CC} = 5V ± 10% C _L = 50pF, R _L = 500Ω		
				MIN	TYP	MAX	MIN	MAX	
t _{PLH} t _{PHL}	Propagation delay Dna, Dnb, Dnc to Qn	74F723A	Waveform 1, 2	2.5	5.0	8.0	2.0	8.5	ns
t _{PLH} t _{PHL}				2.0	4.5	7.0	2.0	7.5	ns
t _{PLH} t _{PHL}	Propagation delay S0, S1, $\overline{\text{INV}}$ to Qn		Waveform 1, 3	6.5	9.0	12.5	4.0	14.0	ns
t _{PLH} t _{PHL}				4.0	7.5	11.0	3.5	12.0	ns
t _{PZH} t _{PZL}	Output Enable time OE to Qn	Waveform 4 Waveform 5	2.0	4.0	6.5	2.0	7.5	ns	
t _{PZH} t _{PZL}			2.5	4.5	7.0	2.0	7.5	ns	
t _{PHZ} t _{PLZ}	Output Disable time OE to Qn	Waveform 4 Waveform 5	2.5	4.0	7.0	2.0	7.5	ns	
t _{PHZ} t _{PLZ}			3.0	5.0	7.5	2.5	8.5	ns	
t _{PLH} t _{PHL}	Propagation delay Dna, Dnb, Dnc to Qn	74F723-1	Waveform 1, 2	2.5	6.0	8.5	2.5	9.5	ns
t _{PLH} t _{PHL}				2.5	5.0	8.0	2.0	8.0	ns
t _{PLH} t _{PHL}	Propagation delay S0, S1, $\overline{\text{INV}}$ to Qn		Waveform 1, 3	7.0	10.0	14.0	6.0	16.0	ns
t _{PLH} t _{PHL}				5.0	9.0	12.5	4.5	13.5	ns
t _{PZH} t _{PZL}	Output Enable time OE to Qn	Waveform 4 Waveform 5	3.0	4.5	7.5	2.5	8.0	ns	
t _{PZH} t _{PZL}			3.0	5.0	7.5	3.0	8.0	ns	
t _{PHZ} t _{PLZ}	Output Disable time OE to Qn	Waveform 4 Waveform 5	2.5	4.5	7.0	2.0	8.0	ns	
t _{PHZ} t _{PLZ}			4.0	6.0	8.5	3.0	9.5	ns	

AC ELECTRICAL CHARACTERISTICS – 74F725A/74F725-1

SYMBOL	PARAMETER		TEST CONDITION	LIMITS					UNIT
				T _{amb} = +25°C V _{CC} = 5V C _L = 50pF, R _L = 500Ω			T _{amb} = 0 to +70°C V _{CC} = 5V ± 10% C _L = 50pF, R _L = 500Ω		
				MIN	TYP	MAX	MIN	MAX	
t _{PLH} t _{PHL}	Propagation delay Dna, Dnb, Dnc, Dnd to Qn	74F725A	Waveform 1, 2	2.0	3.5	6.5	2.0	7.0	ns
t _{PLH} t _{PHL}				2.0	3.5	6.5	2.0	6.5	ns
t _{PLH} t _{PHL}	Propagation delay S0, S1 to Qn	74F725-1	Waveform 1	6.0	8.5	11.5	5.5	13.5	ns
t _{PLH} t _{PHL}	Propagation delay Dna, Dnb, Dnc, Dnd to Qn		Waveform 1, 2	5.0	7.0	10.0	4.5	10.5	ns
t _{PLH} t _{PHL}				2.0	4.0	7.0	2.0	7.5	ns
t _{PLH} t _{PHL}	2.0		4.0	6.5	2.0	7.5	ns		
t _{PLH} t _{PHL}	Propagation delay S0, S1 to Qn	Waveform 1	6.5	9.0	12.0	5.5	14.0	ns	
t _{PLH} t _{PHL}			5.0	8.5	10.5	5.0	11.0	ns	

Multiplexers

74F723A/74F723-1/
74F725A/74F725-1

AC WAVEFORMS

For all waveforms, $V_M = 1.5V$

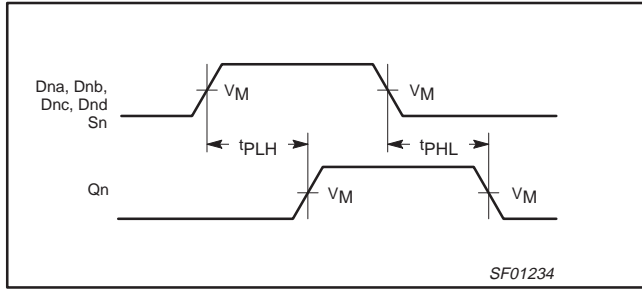

Waveform 1. Propagation Delay for Non-Inverting Output

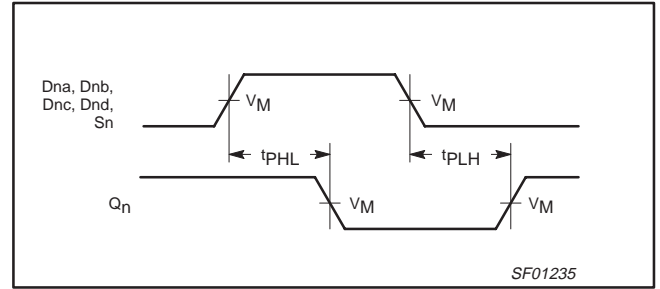

Waveform 2. Propagation Delay for Inverting Output

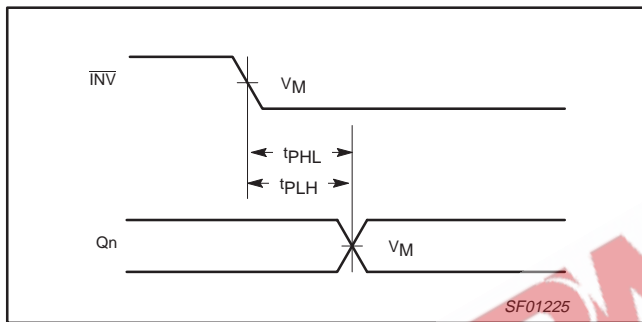

Waveform 3. Propagation Delay for INV to Output

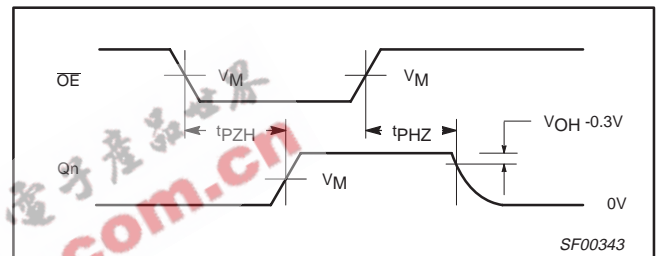

Waveform 4. 3-State Output Enable Time to High Level and Output Disable Time from High Level

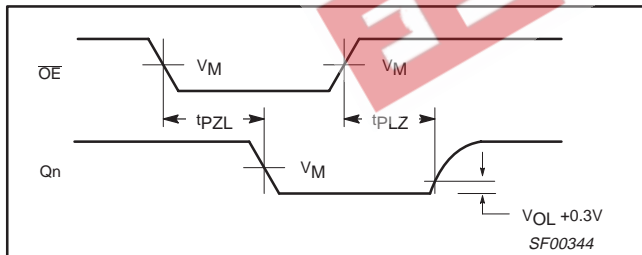

Waveform 5. 3-State Output Enable Time to Low Level and Output Disable Time from Low Level

Multiplexers

74F723A/74F723-1/ 74F725A/74F725-1

TEST CIRCUIT AND WAVEFORMS

Test Circuit for 3-State Outputs

SWITCH POSITION

TEST	SWITCH
t_{PLZ}	closed
t_{pZL}	closed
All other	open

DEFINITIONS:
 R_L = Load resistor; see AC electrical characteristics for value.
 C_L = Load capacitance includes jig and probe capacitance; see AC electrical characteristics for value.
 R_T = Termination resistance should be equal to Z_{OUT} of pulse generators.

Input Pulse Definition

INPUT PULSE REQUIREMENTS						
family	amplitude	V_M	rep. rate	t_w	t_{TLH}	t_{THL}
74F	3.0V	1.5V	1MHz	500ns	2.5ns	2.5ns

SF00777

Multiplexers

74F723A/723-1,
74F725A/725-1

DIP24: plastic dual in-line package; 24 leads (300 mil)

SOT222-1

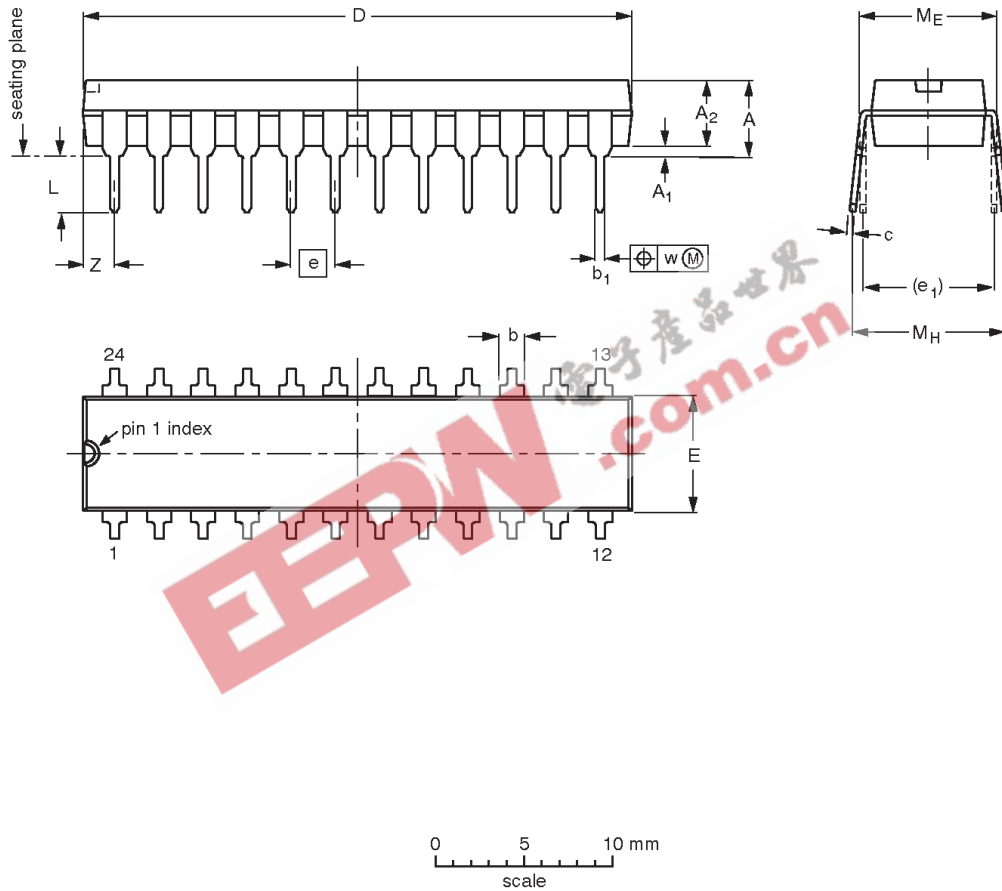

DIMENSIONS (millimetre dimensions are derived from the original inch dimensions)

UNIT	A max.	A1 min.	A2 max.	b	b1	c	D ⁽¹⁾	E ⁽¹⁾	e	e1	L	ME	MH	w	Z ⁽¹⁾ max.
mm	4.70	0.38	3.94	1.63 1.14	0.56 0.43	0.36 0.25	31.9 31.5	6.73 6.48	2.54	7.62	3.51 3.05	8.13 7.62	10.03 7.62	0.25	2.05
inches	0.185	0.015	0.155	0.064 0.045	0.022 0.017	0.014 0.010	1.256 1.240	0.265 0.255	0.100	0.300	0.138 0.120	0.32 0.30	0.395 0.300	0.01	0.081

Note

1. Plastic or metal protrusions of 0.01 inches maximum per side are not included.

OUTLINE VERSION	REFERENCES				EUROPEAN PROJECTION	ISSUE DATE
	IEC	JEDEC	EIAJ			
SOT222-1		MS-001AF				95-03-11

Multiplexers

74F723A/723-1,
74F725A/725-1

SO24: plastic small outline package; 24 leads; body width 7.5 mm

SOT137-1

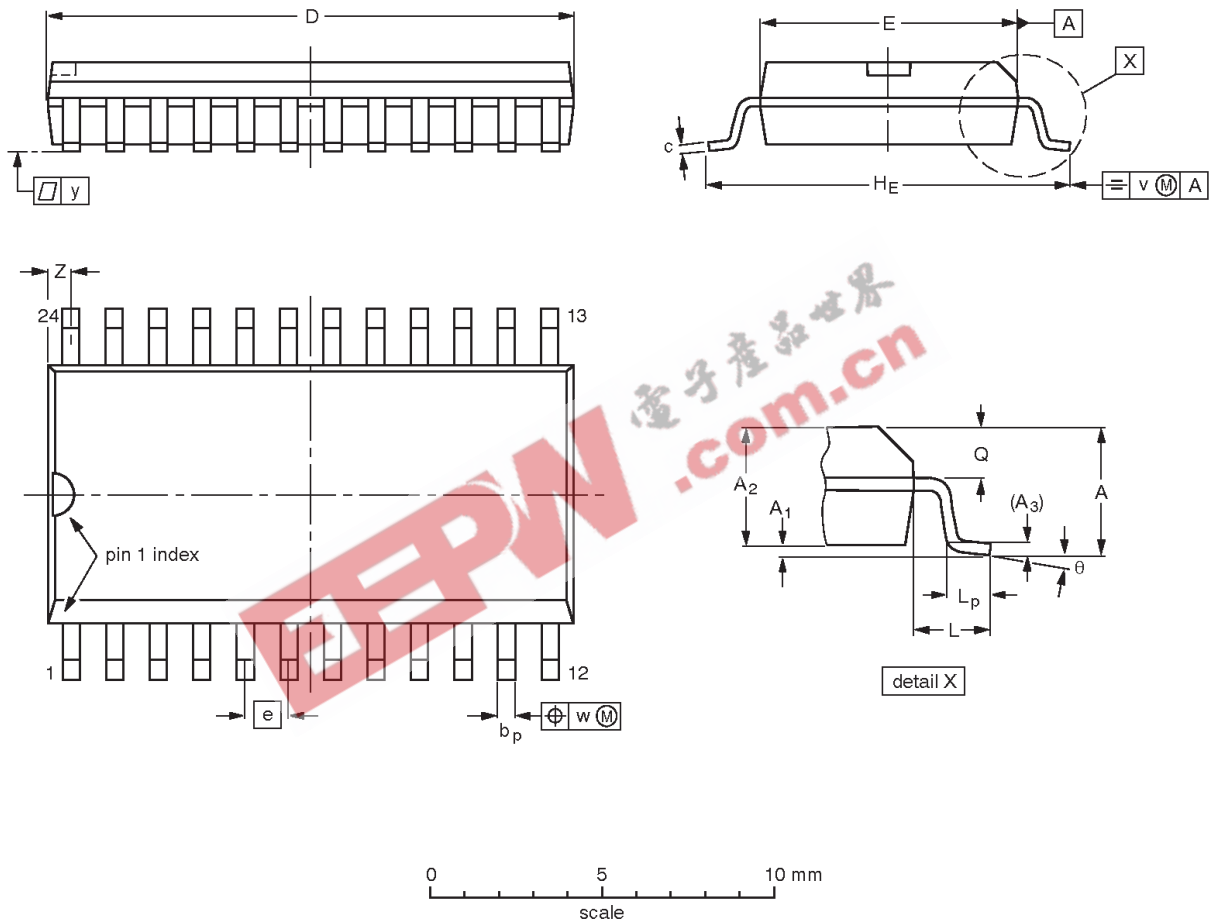

DIMENSIONS (inch dimensions are derived from the original mm dimensions)

UNIT	A max.	A ₁	A ₂	A ₃	b _p	c	D ⁽¹⁾	E ⁽¹⁾	e	H _E	L	L _p	Q	v	w	y	Z ⁽¹⁾	θ
mm	2.65	0.30 0.10	2.45 2.25	0.25	0.49 0.36	0.32 0.23	15.6 15.2	7.6 7.4	1.27	10.65 10.00	1.4	1.1 0.4	1.1 1.0	0.25	0.25	0.1	0.9 0.4	8° 0°
inches	0.10	0.012 0.004	0.096 0.089	0.01	0.019 0.014	0.013 0.009	0.61 0.60	0.30 0.29	0.050	0.419 0.394	0.055	0.043 0.016	0.043 0.039	0.01	0.01	0.004	0.035 0.016	

Note

1. Plastic or metal protrusions of 0.15 mm maximum per side are not included.

OUTLINE VERSION	REFERENCES				EUROPEAN PROJECTION	ISSUE DATE
	IEC	JEDEC	EIAJ			
SOT137-1	075E05	MS-013AD				95-01-24 97-05-22

Multiplexers

74F723A/723-1,
74F725A/725-1

NOTES



Multiplexers

74F723A/723-1,
74F725A/725-1

Data sheet status

Data sheet status	Product status	Definition [1]
Objective specification	Development	This data sheet contains the design target or goal specifications for product development. Specification may change in any manner without notice.
Preliminary specification	Qualification	This data sheet contains preliminary data, and supplementary data will be published at a later date. Philips Semiconductors reserves the right to make changes at any time without notice in order to improve design and supply the best possible product.
Product specification	Production	This data sheet contains final specifications. Philips Semiconductors reserves the right to make changes at any time without notice in order to improve design and supply the best possible product.

[1] Please consult the most recently issued datasheet before initiating or completing a design.

Definitions

Short-form specification — The data in a short-form specification is extracted from a full data sheet with the same type number and title. For detailed information see the relevant data sheet or data handbook.

Limiting values definition — Limiting values given are in accordance with the Absolute Maximum Rating System (IEC 134). Stress above one or more of the limiting values may cause permanent damage to the device. These are stress ratings only and operation of the device at these or at any other conditions above those given in the Characteristics sections of the specification is not implied. Exposure to limiting values for extended periods may affect device reliability.

Application information — Applications that are described herein for any of these products are for illustrative purposes only. Philips Semiconductors make no representation or warranty that such applications will be suitable for the specified use without further testing or modification.

Disclaimers

Life support — These products are not designed for use in life support appliances, devices or systems where malfunction of these products can reasonably be expected to result in personal injury. Philips Semiconductors customers using or selling these products for use in such applications do so at their own risk and agree to fully indemnify Philips Semiconductors for any damages resulting from such application.

Right to make changes — Philips Semiconductors reserves the right to make changes, without notice, in the products, including circuits, standard cells, and/or software, described or contained herein in order to improve design and/or performance. Philips Semiconductors assumes no responsibility or liability for the use of any of these products, conveys no license or title under any patent, copyright, or mask work right to these products, and makes no representations or warranties that these products are free from patent, copyright, or mask work right infringement, unless otherwise specified.

Philips Semiconductors
811 East Arques Avenue
P.O. Box 3409
Sunnyvale, California 94088-3409
Telephone 800-234-7381

© Copyright Philips Electronics North America Corporation 1998
All rights reserved. Printed in U.S.A.

print code

Date of release: 10-98

Document order number:

9397-750-05175

Let's make things better.