



# 0.1 $\mu$ F, +5 V Powered CMOS RS-232 Drivers/Receivers

## ADM205–ADM211/ADM213

### FEATURES

- 0.1  $\mu$ F to 10  $\mu$ F Capacitors
- 120 kB/s Data Rate
- 2 Receivers Active in Shutdown (ADM213)
- On-Board DC-DC Converters
- $\pm 9$  V Output Swing with +5 V Supply
- Low Power (15 mW)
- Low Power Shutdown  $\leq 5 \mu$ W
- $\pm 30$  V Receiver Input Levels
- Latch-Up FREE
- Plug-In Upgrade for MAX205-211/213

### APPLICATIONS

- Computers
- Peripherals
- Modems
- Printers
- Instruments

### TYPICAL OPERATING CIRCUIT

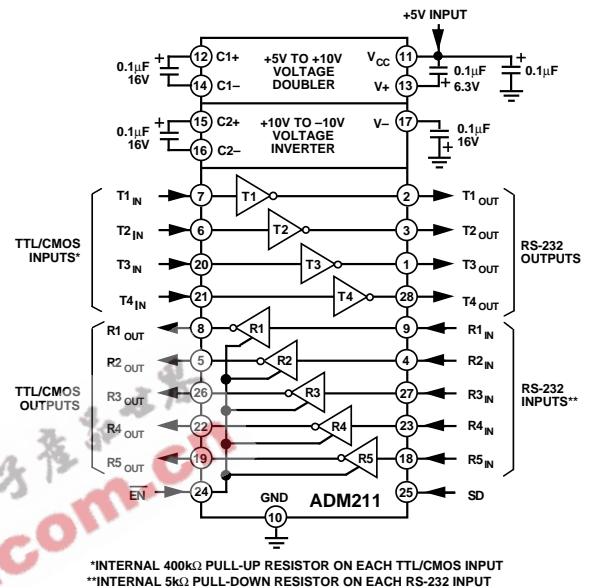

\*INTERNAL 400k $\Omega$  PULL-UP RESISTOR ON EACH TTL/CMOS INPUT  
 \*\*INTERNAL 5k $\Omega$  PULL-DOWN RESISTOR ON EACH RS-232 INPUT

### GENERAL DESCRIPTION

The ADM2xx family of line drivers/receivers is intended for all EIA-232-E and V.28 communications interfaces, especially in applications where  $\pm 12$  V is not available. The ADM205, ADM206, ADM211 and ADM213 feature a low power shutdown mode which reduces power dissipation to less than 5  $\mu$ W making them ideally suited for battery powered equipment. The ADM205 does not require any external components and is particularly useful in applications where printed circuit board space is critical. The ADM213 has an active-low shutdown and an

active-high receiver enable control. Two receivers of the ADM213 remain active during shutdown. This feature is useful for ring indicator monitoring.

All members of the ADM2xx family, except the ADM209, include two internal charge pump voltage converters which allow operation from a single +5 V supply. These converters convert the +5 V input power to the  $\pm 10$  V required for RS-232 output levels. The ADM209 is designed to operate from +5 V and +12 V supplies. An internal +12 V to -12 V charge pump voltage converter generates the -12 V supply.

Table I. Selection Table

Part Number	Power Supply Voltage	No. of RS-232 Drivers	No. of RS-232 Receivers	External Capacitors	Low Power Shutdown (SD)	TTL Three-State $\overline{\text{EN}}$	No. of Receivers Active in Shutdown
ADM205	+5 V	5	5	None	Yes	Yes	0
ADM206	+5 V	4	3	4	Yes	Yes	0
ADM207	+5 V	5	3	4	No	No	0
ADM208	+5 V	4	4	4	No	No	0
ADM209	+5 V & +9 V to +13.2 V	3	5	2	No	Yes	0
ADM211	+5 V	4	5	4	Yes	Yes	0
ADM213	+5 V	4	5	4	Yes ( $\overline{\text{SD}}$ )	Yes (EN)	2

REV. 0

Information furnished by Analog Devices is believed to be accurate and reliable. However, no responsibility is assumed by Analog Devices for its use, nor for any infringements of patents or other rights of third parties which may result from its use. No license is granted by implication or otherwise under any patent or patent rights of Analog Devices.

© Analog Devices, Inc., 1994

One Technology Way, P.O. Box 9106, Norwood, MA 02062-9106, U.S.A.  
 Tel: 617/329-4700 Fax: 617/326-8703

# ADM205–ADM211/ADM213–SPECIFICATIONS (V<sub>CC</sub> = +5 V ± 10% (206, 207, 208, 209, 211, 213); V<sub>CC</sub> = +5 V ± 5% (ADM205);

V+ = +9 V to +13.2 V (ADM209); C1–C4 = 0.1 μF Ceramic. All Specifications T<sub>MIN</sub> to T<sub>MAX</sub> unless otherwise noted.)

Parameter	Min	Typ	Max	Units	Test Conditions/Comments
Output Voltage Swing	±5	±9		Volts	All Transmitter Outputs Loaded with 3 kΩ to Ground
V <sub>CC</sub> Power Supply Current		3	7	mA	No Load, ADM206, ADM211, ADM213
		5	9	mA	No Load, ADM205, ADM207, ADM208
		0.4	1	mA	No Load, ADM209
V+ Power Supply Current		3.5	5	mA	No Load, V+ = 12 V ADM209 Only
Shutdown Supply Current		1	5	μA	
Input Logic Threshold Low, V <sub>INL</sub>			0.8	V	T <sub>IN</sub> , $\overline{EN}$ , SD, EN, $\overline{SD}$
Input Logic Threshold High, V <sub>INH</sub>	2.0			V	T <sub>IN</sub> , $\overline{EN}$ , SD, EN, $\overline{SD}$
Logic Pull-Up Current		10	25	μA	T <sub>IN</sub> = 0 V
RS-232 Input Voltage Range	–30		+30	V	
RS-232 Input Threshold Low	0.8	1.2		V	
RS-232 Input Threshold High		1.7	2.4	V	
RS-232 Input Hysteresis	0.2	0.5	1.0	V	
RS-232 Input Resistance	3	5	7	kΩ	
TTL/CMOS Output Voltage Low, V <sub>OL</sub>			0.4	V	I <sub>OUT</sub> = 1.6 mA
TTL/CMOS Output Voltage High, V <sub>OH</sub>	3.5			V	I <sub>OUT</sub> = –1.0 mA
TTL/CMOS Output Leakage Current		0.05	±5	μA	$\overline{EN} = V_{CC}$ , EN = 0 V, 0 V ≤ R <sub>OUT</sub> ≤ V <sub>CC</sub>
Output Enable Time (T <sub>EN</sub> )		115		ns	ADM205, ADM206, ADM209, ADM211 (Figure 25. C <sub>L</sub> = 150 pF)
Output Disable Time (T <sub>DIS</sub> )		165		ns	ADM205, ADM206, ADM209, ADM211 (Figure 25. R <sub>L</sub> = 1 kΩ)
Propagation Delay		0.5	5	μs	RS-232 to TTL
Instantaneous Slew Rate <sup>1</sup>		25	30	V/μs	C <sub>L</sub> = 10 pF, R <sub>L</sub> = 3–7 kΩ, T <sub>A</sub> = +25°C
Transition Region Slew Rate	3	6		V/μs	R <sub>L</sub> = 3 kΩ, C <sub>L</sub> = 2500 pF
Output Resistance	300			Ω	Measured from +3 V to –3 V or –3 V to +3 V
RS-232 Output Short Circuit Current		±12	±60	mA	V <sub>CC</sub> = V+ = V– = 0 V, V <sub>OUT</sub> = ±2 V

## NOTE

<sup>1</sup>Sample tested to ensure compliance.

Specifications subject to change without notice.

## ABSOLUTE MAXIMUM RATINGS\*

(T<sub>A</sub> = +25°C unless otherwise noted)

V <sub>CC</sub>	–0.3 V to +6 V
V+	(V <sub>CC</sub> – 0.3 V) to +14 V
V–	+0.3 V to –14 V

### Input Voltages

T <sub>IN</sub>	–0.3 V to (V <sub>CC</sub> + 0.3 V)
R <sub>IN</sub>	±30 V

### Output Voltages

T <sub>OUT</sub>	(V+, +0.3 V) to (V–, –0.3 V)
R <sub>OUT</sub>	–0.3 V to (V <sub>CC</sub> + 0.3 V)

### Short Circuit Duration

T <sub>OUT</sub>	Continuous
------------------	------------

### Power Dissipation

N-24 DIP (Derate 13.5 mW/°C above +70°C)	1000 mW
N-24A DIP (Derate 13.5 mW/°C above +70°C)	500 mW
R-24 SOIC (Derate 12 mW/°C above +70°C)	850 mW
R-28 SOIC (Derate 12.5 mW/°C above +70°C)	900 mW
RS-28 SSOP (Derate 10 mW/°C above +70°C)	900 mW
Q-24 Cerdip (Derate 12.5 mW/°C above +70°C)	1000 mW
D-24 Ceramic (Derate 20 mW/°C above +70°C)	1000 mW

### Thermal Impedance, θ<sub>JA</sub>

N-24 DIP	120°C/W
N-24A DIP	110°C/W
R-24 SOIC	85°C/W
R-28 SOIC	80°C/W
RS-28 SSOP	100°C/W
Q-14 Cerdip	105°C/W
Q-16 Cerdip	100°C/W
Q-20 Cerdip	100°C/W
Q-24 Cerdip	55°C/W
D-24 Ceramic	50°C/W

### Operating Temperature Range

Industrial (A Version)	–40°C to +85°C
------------------------	----------------

### Storage Temperature Range

	–65°C to +150°C
--	-----------------

### Lead Temperature, Soldering

Vapour Phase (60 sec)	+215°C
-----------------------	--------

### Infrared (15 sec)

	+220°C
--	--------

### ESD Rating

	> 2000 V
--	----------

\*This is a stress rating only and functional operation of the device at these or any other conditions above those indicated in the operation sections of this specification is not implied. Exposure to absolute maximum rating conditions for extended periods of time may affect reliability.

# ADM205-ADM211/ADM213

## ORDERING GUIDE

Model	Temperature Range	Package Option*	Model	Temperature Range	Package Option*	Model	Temperature Range	Package Option*
<b>ADM205</b> ADM205AN	-40°C to +85°C	N-24A	<b>ADM206</b> ADM206AN ADM206AR ADM206ARS	-40°C to +85°C -40°C to +85°C -40°C to +85°C	N-24 R-24 RS-24	<b>ADM207</b> ADM207AN ADM207AR ADM207ARS	-40°C to +85°C -40°C to +85°C -40°C to +85°C	N-24 R-24 RS-24
<b>ADM208</b> ADM208AN ADM208AR ADM208ARS	-40°C to +85°C -40°C to +85°C -40°C to +85°C	N-24 R-24 RS-24	<b>ADM209</b> ADM209AN ADM209AR ADM209ARS	-40°C to +85°C -40°C to +85°C -40°C to +85°C	N-24 R-24 RS-24	<b>ADM211</b> ADM211AR ADM211ARS	-40°C to +85°C -40°C to +85°C	R-28 RS-28
<b>ADM213</b> ADM213AR ADM213ARS	-40°C to +85°C -40°C to +85°C	R-28 RS-28						

\*N = Plastic DIP; R = Small Outline IC (SOIC); RS = Small Shrink Outline Package (SSOP).

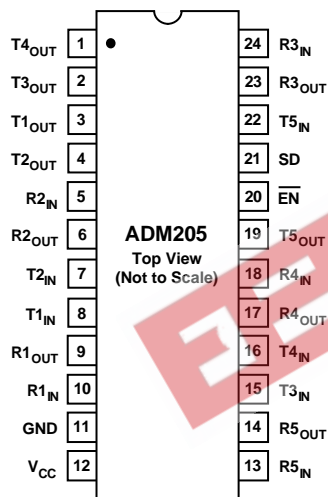
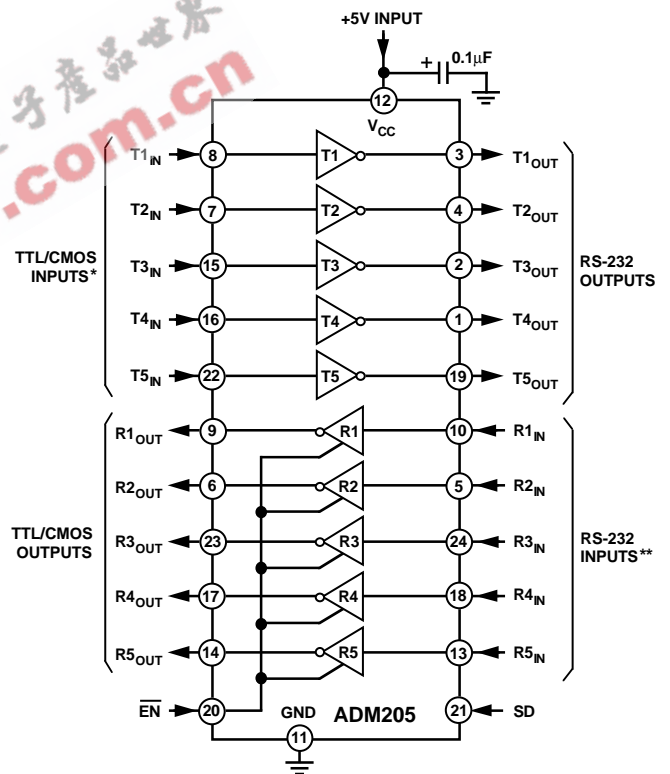

Figure 1. ADM205 DIP Pin Configuration



\*INTERNAL 400kΩ PULL-UP RESISTOR ON EACH TTL/CMOS INPUT  
 \*\*INTERNAL 5kΩ PULL-DOWN RESISTOR ON EACH RS-232 INPUT

Figure 2. ADM205 Typical Operating Circuit

# ADM205-ADM211/ADM213

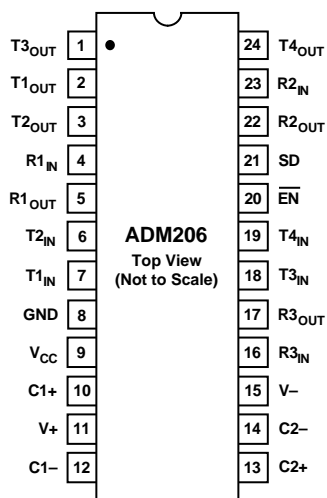

Figure 3. ADM206 DIP/SOIC/SSOP Pin Configuration

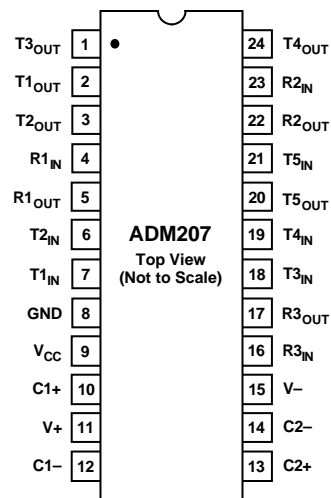
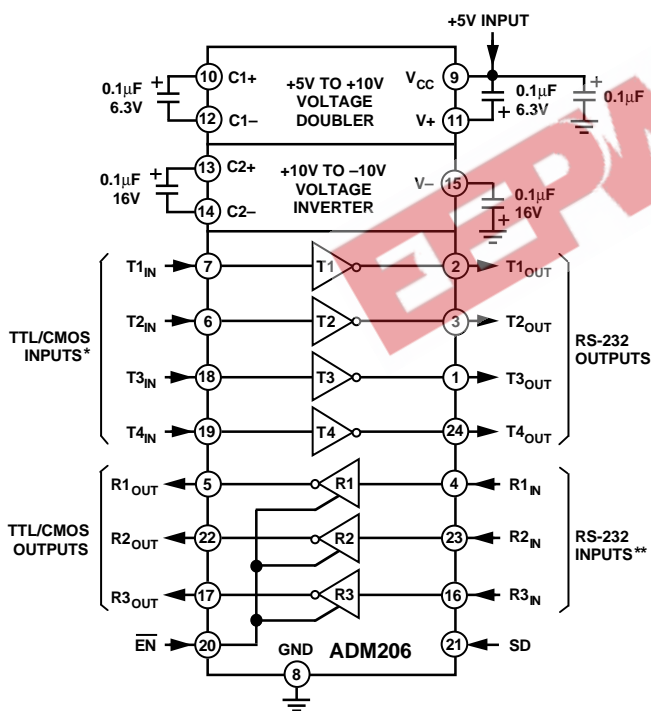
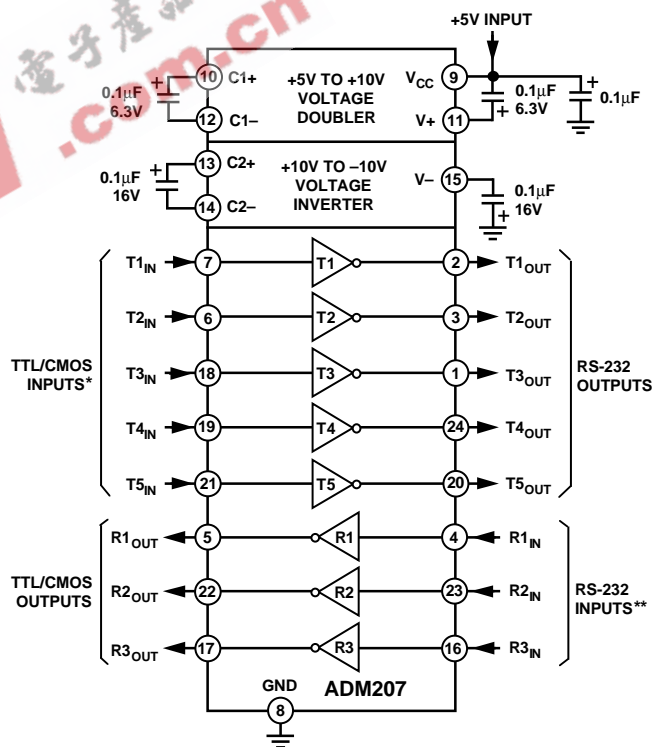

Figure 5. ADM207 DIP/SOIC/SSOP Pin Configuration



\*INTERNAL 400kΩ PULL-UP RESISTOR ON EACH TTL/CMOS INPUT  
 \*\*INTERNAL 5kΩ PULL-DOWN RESISTOR ON EACH RS-232 INPUT

Figure 4. ADM206 Typical Operating Circuit



\*INTERNAL 400kΩ PULL-UP RESISTOR ON EACH TTL/CMOS INPUT  
 \*\*INTERNAL 5kΩ PULL-DOWN RESISTOR ON EACH RS-232 INPUT

Figure 6. ADM207 Typical Operating Circuit

# ADM205-ADM211/ADM213

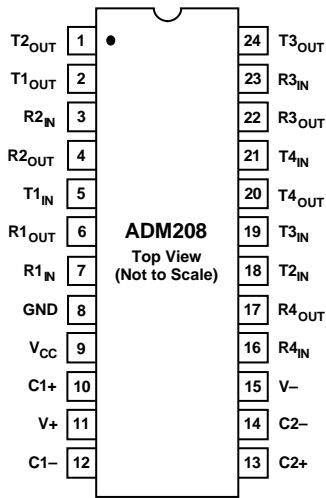
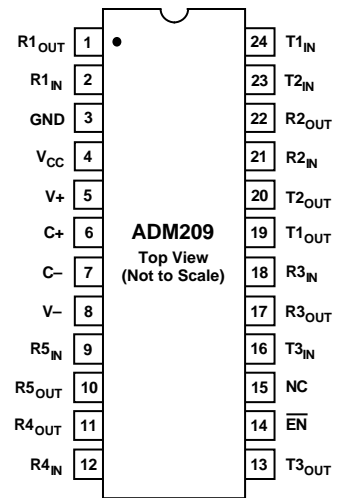
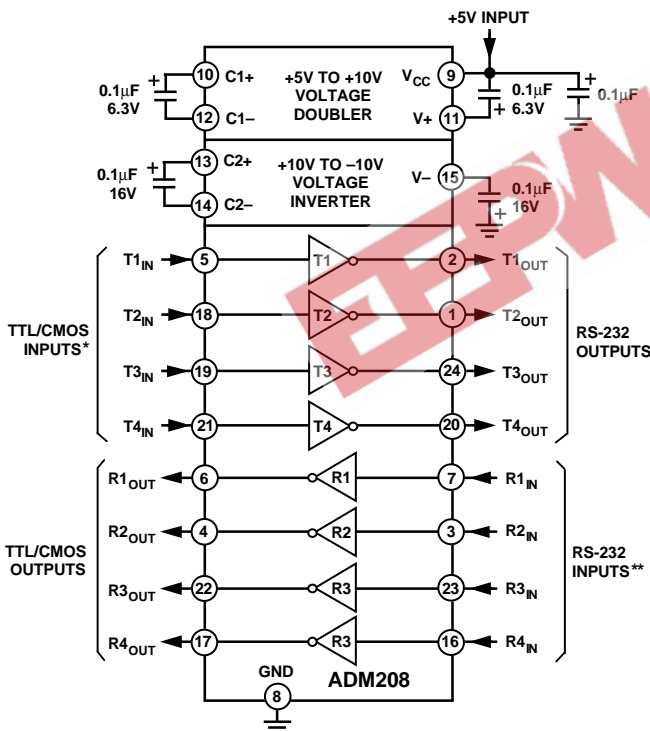

Figure 7. ADM208 DIP/SOIC/SSOP Pin Configuration



NC = NO CONNECT

Figure 9. ADM209 DIP/SOIC/SSOP Pin Configuration



\*INTERNAL 400kΩ PULL-UP RESISTOR ON EACH TTL/CMOS INPUT  
 \*\*INTERNAL 5kΩ PULL-DOWN RESISTOR ON EACH RS-232 INPUT

Figure 8. ADM208 Typical Operating Circuit

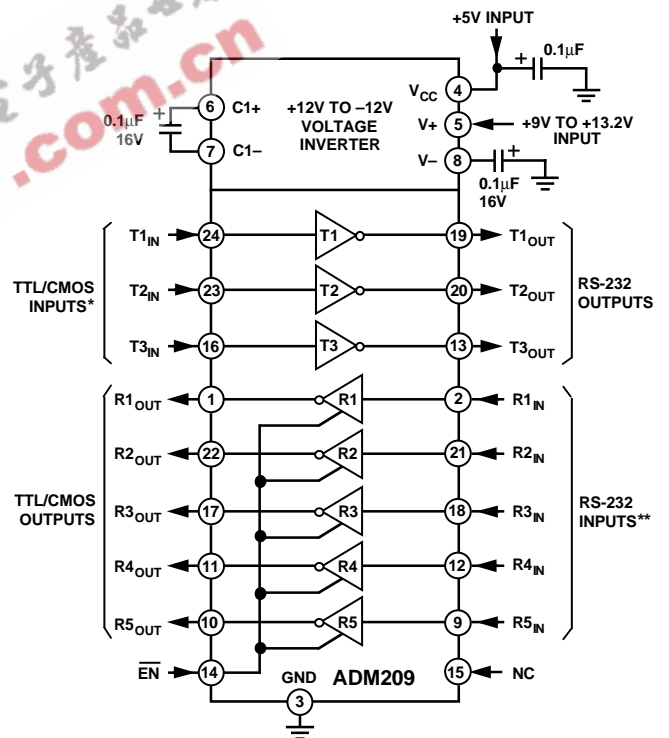

\*INTERNAL 400kΩ PULL-UP RESISTOR ON EACH TTL/CMOS INPUT  
 \*\*INTERNAL 5kΩ PULL-DOWN RESISTOR ON EACH RS-232 INPUT

Figure 10. ADM209 Typical Operating Circuit

# ADM205-ADM211/ADM213

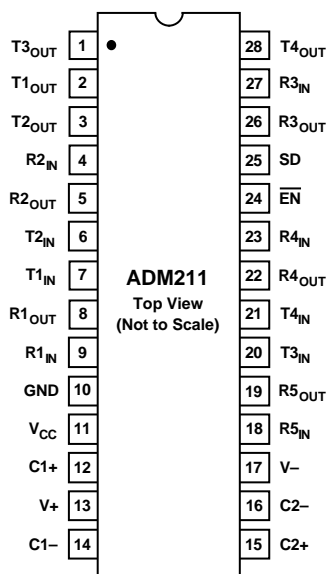

Figure 11. ADM211 SOIC/SSOP Pin Configuration

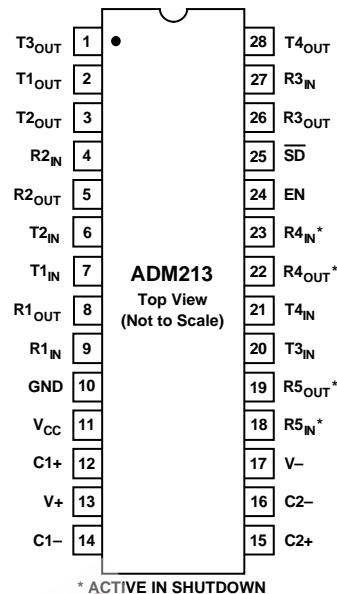
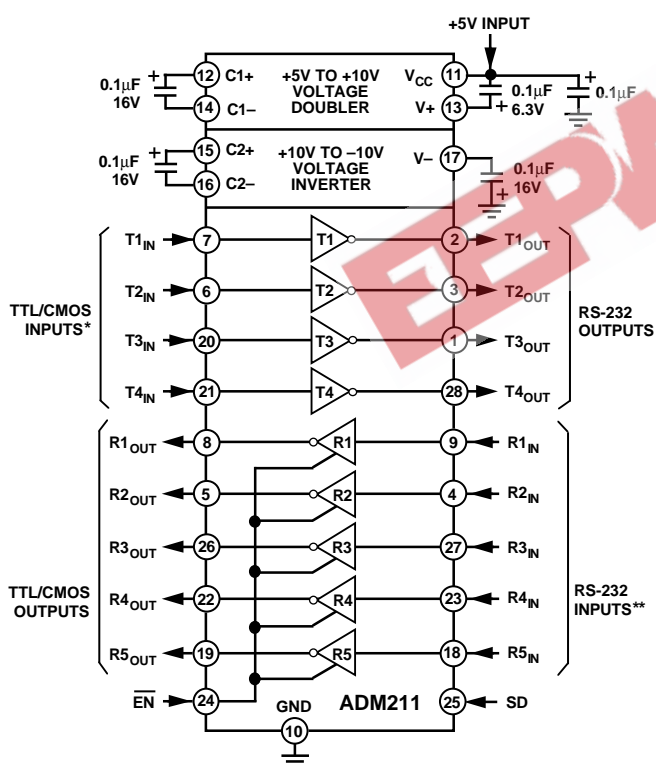
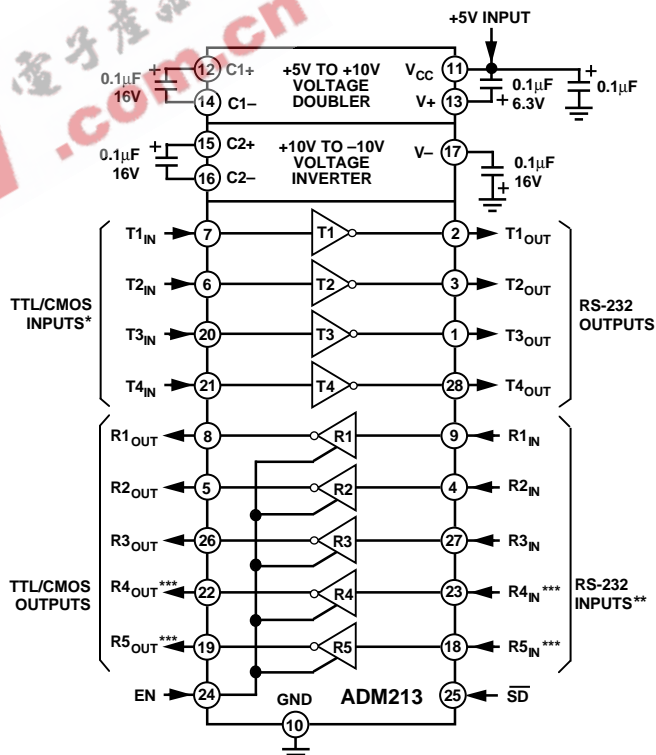

Figure 13. ADM213 SOIC/SSOP Pin Configuration



\*INTERNAL 400kΩ PULL-UP RESISTOR ON EACH TTL/CMOS INPUT  
 \*\*INTERNAL 5kΩ PULL-DOWN RESISTOR ON EACH RS-232 INPUT

Figure 12. ADM211 Typical Operating Circuit



\* INTERNAL 400kΩ PULL-UP RESISTOR ON EACH TTL/CMOS INPUT  
 \*\* INTERNAL 5kΩ PULL-DOWN RESISTOR ON EACH RS-232 INPUT  
 \*\*\* ACTIVE IN SHUTDOWN

Figure 14. ADM213 Typical Operating Circuit

# ADM205–ADM211/ADM213

## PIN FUNCTION DESCRIPTION

Mnemonic	Function
V <sub>CC</sub>	Power Supply Input 5 V ± 10% (+5 V ± 5% ADM205).
V+	Internally generated positive supply (+10 V nominal) on all parts except ADM209. ADM209 requires external 9 V to 13.2 V supply.
V-	Internally generated negative supply (-10 V nominal).
GND	Ground pin. Must be connected to 0 V.
C+	(ADM209 only) External capacitor (+ terminal) is connected to this pin.
C-	(ADM209 only) External capacitor (- terminal) is connected to this pin.
C1+	(ADM206, ADM207, ADM208, ADM211, ADM213) External capacitor (+ terminal) is connected to this pin.
C1-	(ADM206, ADM207, ADM208, ADM211, ADM213) External capacitor (- terminal) is connected to this pin.
C2+	(ADM206, ADM207, ADM208, ADM211, ADM213) External capacitor (+ terminal) is connected to this pin.
C2-	(ADM206, ADM207, ADM208, ADM211, ADM213) External capacitor (- terminal) is connected to this pin.
T <sub>IN</sub>	Transmitter (Driver) Inputs. These inputs accept TTL/CMOS levels. An internal 400 kΩ pull-up resistor to V <sub>cc</sub> is connected on each input.
T <sub>OUT</sub>	Transmitter (Driver) Outputs. These are RS-232 levels (typically ±10 V).
R <sub>IN</sub>	Receiver Inputs. These inputs accept RS-232 signal levels. An internal 5 kΩ pull-down resistor to GND is connected on each input.
R <sub>OUT</sub>	Receiver Outputs. These are TTL/CMOS levels.
$\overline{\text{EN}}/\text{EN}$	Enable Input. Active low on ADM205, ADM206, ADM209, ADM211. Active high on ADM213. This input is used to enable/disable the receiver outputs. With $\overline{\text{EN}}$ = Low (EN = High ADM213), the receiver outputs are enabled. With $\overline{\text{EN}}$ = High (EN = low ADM213), the outputs are placed in a high impedance state. This facility is useful for connecting to microprocessor systems.
SD/ $\overline{\text{SD}}$	Shutdown Input. Active high on ADM205, ADM206, ADM211. Active low on ADM213. With SD = high on the ADM205, ADM206, ADM211, the charge pump is disabled, the receiver outputs are placed in a high impedance state and the driver outputs are turned off. With $\overline{\text{SD}}$ low on the ADM213, the charge pump is disabled, the driver outputs are turned off and all receivers except R4 and R5 are placed in a high impedance state. In shutdown, the power consumption reduces to 5 μW.
NC	No Connect. No connections are required to this pin.

**Table II. ADM205, ADM206, ADM211 Truth Table**

SD	$\overline{\text{EN}}$	Status	Transmitters T1-T5	Receivers R1-R5
0	0	Normal Operation	Enabled	Enabled
0	1	Normal Operation	Enabled	Disabled
1	0	Shutdown	Disabled	Disabled

**Table III. ADM213 Truth Table**

$\overline{\text{SD}}$	EN	Status	Transmitters T1-T4	Receivers R1-R3	Receivers R4, R5
0	0	Shutdown	Disabled	Disabled	Disabled
0	1	Shutdown	Disabled	Disabled	Enabled
1	0	Normal Operation	Enabled	Disabled	Disabled
1	1	Normal Operation	Enabled	Enabled	Enabled

# ADM205–ADM211/ADM213–Typical Performance Characteristics

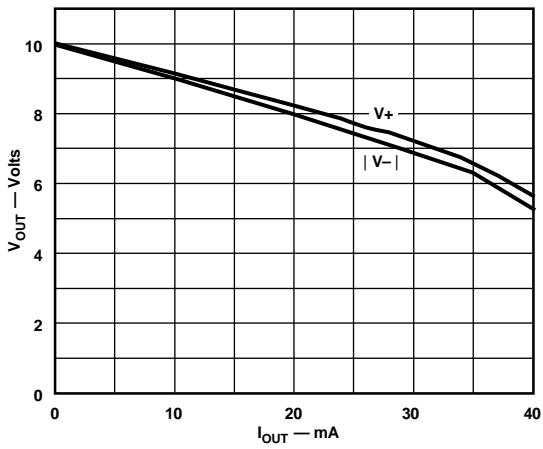

Figure 15. Charge Pump  $V_+$ ,  $V_-$  vs. Current

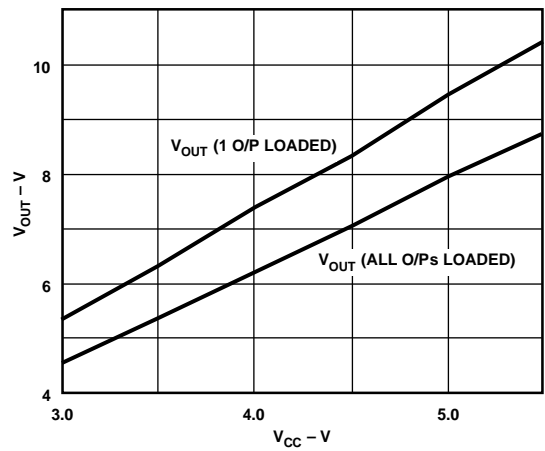

Figure 17. Transmitter Output Voltage vs.  $V_{CC}$

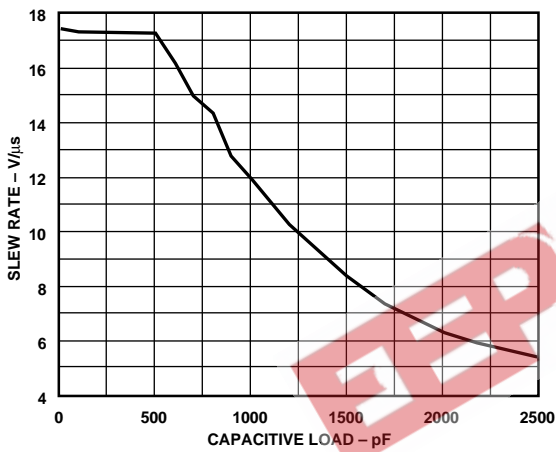

Figure 16. Transmitter Slew Rate vs. Load Capacitance

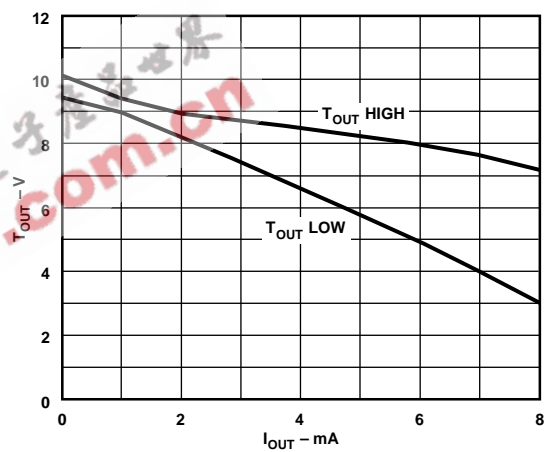

Figure 18. Transmitter Output Voltage vs. Current

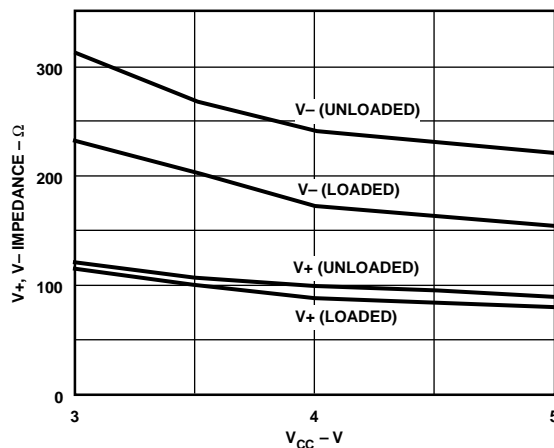

Figure 19. Charge Pump Impedance vs.  $V_{CC}$



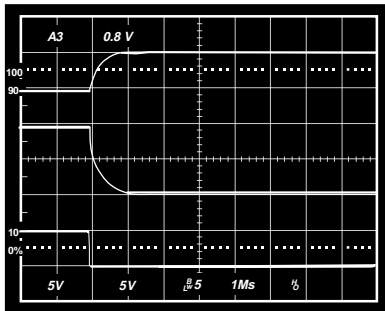

Figure 20. Charge Pump,  $V_+$ ,  $V_-$  Exiting Shutdown

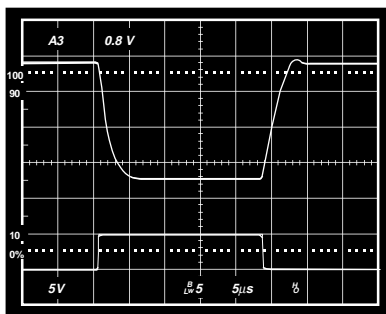

Figure 21. Transmitter Output Loaded Slew Rate

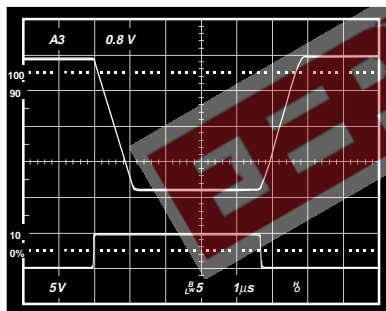

Figure 22. Transmitter Output Unloaded Slew Rate

## GENERAL INFORMATION

The ADM205-ADM211 and ADM213 family of RS-232 drivers/receivers are designed to solve interface problems by meeting the EIA-232-E specifications while using a single digital +5 V supply. The EIA-232-E standard requires transmitters which will deliver  $\pm 5$  V minimum on the transmission channel and receivers which can accept signal levels down to  $\pm 3$  V. The ADM205-ADM211 and ADM213 meet these requirements by integrating step up voltage converters and level shifting transmitters and receivers onto the same chip. CMOS technology is used to keep the power dissipation to an absolute minimum. A comprehensive range of transmitter/receiver combinations is available to cover most communications needs. The ADM205-ADM211 and ADM213 are modifications, enhancements and improvements to the AD230-AD241 family and derivatives thereof. They are essentially plug-in compatible and do not have materially different applications.

The ADM205, ADM206, ADM211, and ADM213 are particularly useful in battery powered systems as they feature a low power shutdown mode which reduces power dissipation to less than  $5 \mu\text{W}$ .

The ADM205 is designed for applications where space saving is important as the charge pump capacitors are molded into the package.

The ADM209 includes only a negative charge pump converter and are intended for applications where a positive 12 V is available.

To facilitate sharing a common line or for connection to a microprocessor data bus the ADM205, ADM206, ADM209, ADM211 and ADM213 feature an enable ( $\overline{\text{EN}}$ ) function. When disabled, the receiver outputs are placed in a high impedance state.

## CIRCUIT DESCRIPTION

The internal circuitry in the ADM205-ADM211 and ADM213 consists of three main sections. These are:

- (a) A charge pump voltage converter
- (b) RS-232 to TTL/CMOS receivers
- (c) TTL/CMOS to RS-232 transmitters

### Charge Pump DC-DC Voltage Converter

The charge pump voltage converter consists of an oscillator and a switching matrix. The converter generates a  $\pm 10$  V supply from the input 5 V level. This is done in two stages using a switched capacitor technique as illustrated in Figures 23 and 24. First, the 5 V input supply is doubled to 10 V using capacitor C1 as the charge storage element. The 10 V level is then inverted to generate  $-10$  V using C2 as the storage element.

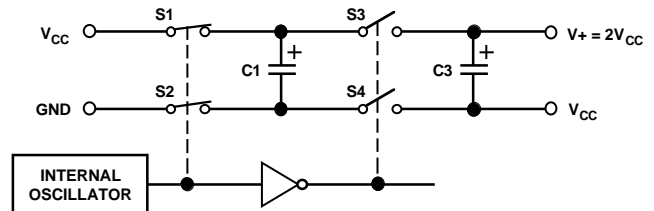

Figure 23. Charge-Pump Voltage Doubler

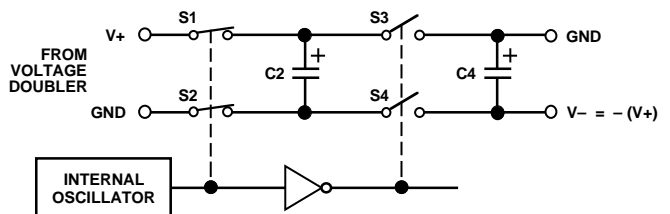

Figure 24. Charge-Pump Voltage Inverter

Capacitors C3 and C4 are used to reduce the output ripple. Their values are not critical and can be reduced if higher levels of ripple are acceptable. The charge pump capacitors C1 and C2 may also be reduced at the expense of higher output impedance on the  $V_+$  and  $V_-$  supplies.

The  $V_+$  and  $V_-$  supplies may also be used to power external circuitry if the current requirements are small.

# ADM205–ADM211/ADM213

## Transmitter (Driver) Section

The drivers convert TTL/CMOS input levels into EIA-232-E output levels. With  $V_{CC} = +5\text{ V}$  and driving a typical EIA-232-E load, the output voltage swing is  $\pm 9\text{ V}$ . Even under worst case conditions the drivers are guaranteed to meet the  $\pm 5\text{ V}$  EIA-232-E minimum requirement.

The input threshold levels are both TTL and CMOS compatible with the switching threshold set at  $V_{CC}/4$ . With a nominal  $V_{CC} = 5\text{ V}$  the switching threshold is  $1.25\text{ V}$  typical. Unused inputs may be left unconnected, as an internal  $400\text{ k}\Omega$  pull-up resistor pulls them high forcing the outputs into a low state.

As required by the EIA-232-E standard, the slew rate is limited to less than  $30\text{ V}/\mu\text{s}$  without the need for an external slew limiting capacitor and the output impedance in the power-off state is greater than  $300\ \Omega$ .

## Receiver Section

The receivers are inverting level shifters which accept EIA-232-E input levels ( $\pm 5\text{ V}$  to  $\pm 15\text{ V}$ ) and translate them into  $5\text{ V}$  TTL/CMOS levels. The inputs have internal  $5\text{ k}\Omega$  pull-down resistors to ground and are also protected against overvoltages of up to  $\pm 30\text{ V}$ . The guaranteed switching thresholds are  $0.8\text{ V}$  minimum and  $2.4\text{ V}$  maximum which are well within the  $\pm 3\text{ V}$  EIA-232-E requirement. The low level threshold is deliberately positive as it ensures that an unconnected input will be interpreted as a low level.

The receivers have Schmitt trigger inputs with a hysteresis level of  $0.5\text{ V}$ . This ensures error-free reception for both noisy inputs and for inputs with slow transition times.

## Shutdown (SD)

The ADM205, ADM206, ADM211 and ADM213 feature a control input which may be used to disable the part and reduce the power consumption to less than  $5\ \mu\text{W}$ . This is very useful in battery operated systems. During shutdown the charge pump is turned off, the transmitters are disabled and all receivers except R4 and R5 on the ADM213 are put into a high-impedance disabled state. Receivers R4 and R5 on the ADM213 remain enabled during shutdown. This feature allows monitoring external activity such as ring indicator monitoring while the device is in a low power shutdown mode. The shutdown control input is active high on all parts except the ADM213 where it is active low. Refer to Tables II and III.

## Enable Input

The ADM205, ADM209, ADM211, and ADM213 feature an enable input used to enable or disable the receiver outputs. The enable input is active low on the ADM205, ADM209, ADM211 and active-high on the ADM213. Refer to Tables II and III. When disabled, all receiver outputs are placed in a high impedance state. This function allows the outputs to be connected directly to a microprocessor data bus. It can also be used to allow receivers from different devices to share a common data line. The timing diagram for the enable function is shown in Figure 25.

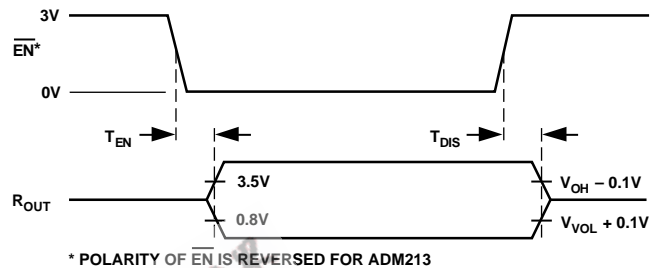

Figure 25. Enable Timing

## APPLICATION HINTS

### Driving Long Cables

In accordance with the EIA-232-E standard, long cables are permissible provided that the total load capacitance does not exceed  $2500\text{ pF}$ . For longer cables which do exceed this, then it is possible to trade off baud rate vs. cable length. Large load capacitances cause a reduction in slew rate, and hence the maximum transmission baud rate is decreased. The ADM205–ADM211 and ADM213 are designed so that the slew rate reduction with increasing load capacitance is minimized.

For the receivers, it is important that a high level of noise immunity be inbuilt so that slow rise and fall times do not cause multiple output transitions as the signal passes slowly through the transition region. The ADM205–ADM211 and ADM213 have  $0.5\text{ V}$  of hysteresis to guard against this. This ensures that, even in noisy environments, error-free reception can be achieved.

### High Baud Rate Operation

The ADM205–ADM211 and ADM213 feature high slew rates permitting data transmission at rates well in excess of the EIA-232-E specification. The drivers maintain  $\pm 5\text{ V}$  signal levels at data rates up to  $120\text{-kB/s}$  under worst-case loading conditions.

# ADM205-ADM211/ADM213

## OUTLINE DIMENSIONS

Dimensions shown in inches and (mm).

### 24-Lead Plastic DIP (N-24)

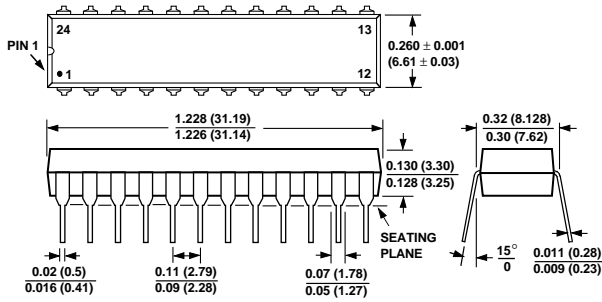

#### NOTES

1. LEAD NO. 1 IDENTIFIED BY DOT OR NOTCH
2. PLASTIC LEADS WILL BE EITHER SOLDER DIPPED OR TIN PLATED IN ACCORDANCE WITH MIL-M-38510 REQUIREMENTS.

### 24-Lead Cerdip (Q-24)

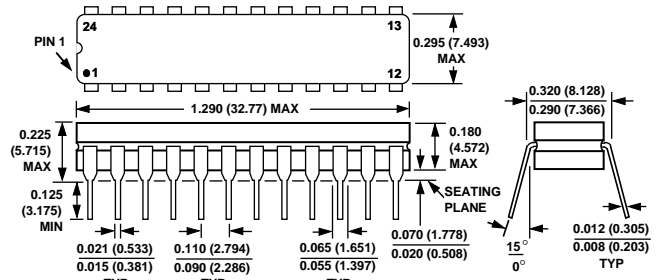

1. LEAD NO. 1 IDENTIFIED BY DOT OR NOTCH.
2. CERDIP LEADS WILL BE EITHER TIN PLATED OR SOLDER DIPPED IN ACCORDANCE WITH MIL-M-38510 REQUIREMENTS.

### 24-Lead Plastic DIP (N-24A)

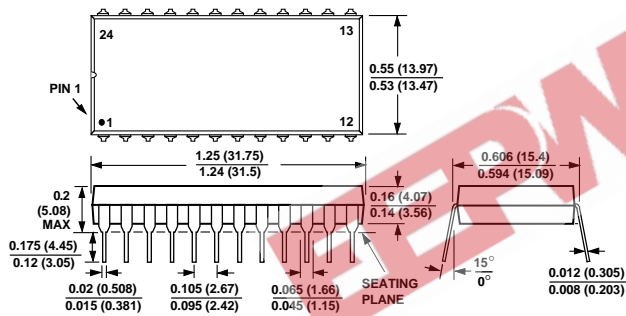

### 28-Lead SOIC (R-28)

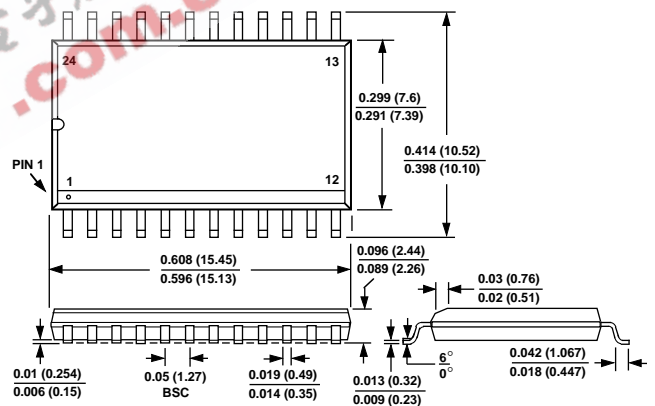

1. LEAD NO. 1 IDENTIFIED BY A DOT.
2. SOIC LEADS WILL BE EITHER TIN PLATED OR SOLDER DIPPED IN ACCORDANCE WITH MIL-M-38510 REQUIREMENTS

### 28-Lead SSOP (RS-28)

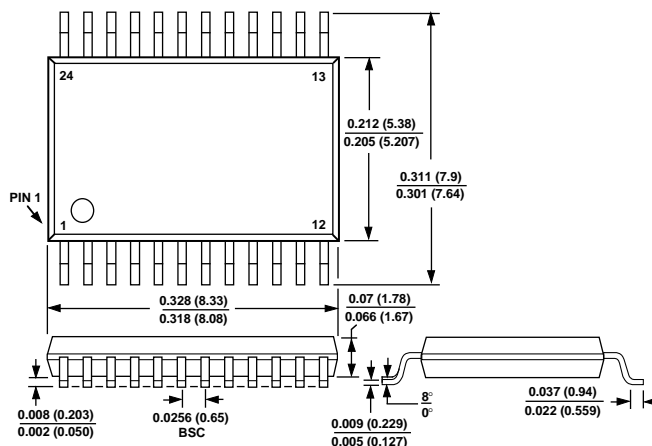

1. LEAD NO. 1 IDENTIFIED BY A DOT.
2. LEADS WILL BE EITHER TIN PLATED OR SOLDER DIPPED IN ACCORDANCE WITH MIL-M-38510 REQUIREMENTS

# ADM205-ADM211/ADM213

## OUTLINE DIMENSIONS

Dimensions shown in inches and (mm).

### 28-Lead SOIC (R-28)

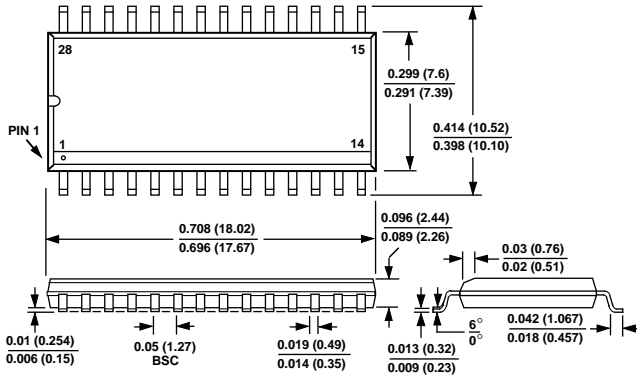

1. LEAD NO. IDENTIFIED BY A DOT.
2. SOICLEADS WILL BE EITHER TIN PLATED OR SOLDER DIPPED IN ACCORDANCE WITH MIL-M-38510 REQUIREMENTS.

### 28-Lead SSOP (RS-28)

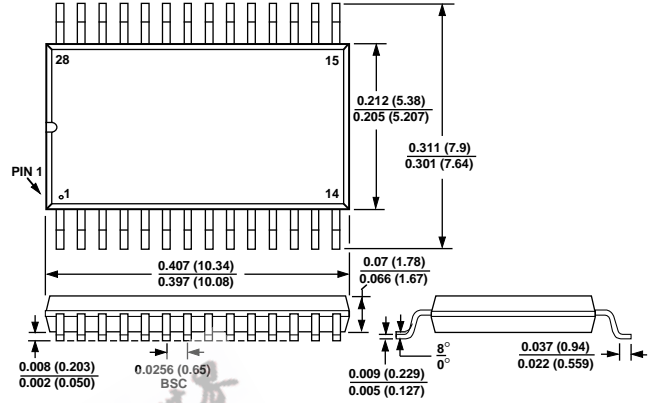

1. LEAD NO. 1 IDENTIFIED BY A DOT.
2. LEADS WILL BE EITHER TIN PLATED OR SOLDER DIPPED IN ACCORDANCE WITH MIL-M-38510 REQUIREMENTS.

EEPW.com.cn 电子产业网