



# DATA SHEET

## AM100~AM1010

**1.0 AMPERE SILICON MINIATURE SINGLE-PHASE BRIDGES**  
**VOLTAGE - 50 to 1000 Volts CURRENT - 1.0 Amperes**

**Recognized File # E111753**

### FEATURES

- Ratings to 1000V PRV
- Surge overload rating: 30 Amperes peak
- Ideal for printed circuit board
- Reliable low cost construction utilizing molded plastic technique
- Mounting position:Any

### MECHANICAL DATA

Case:Reliable low cost construction utilizing molded plastic technique results in inexpensive product.

Terminals: Leads solderable per MIL-STD-202, Method 208

Polarity :Polarity symbols marking on body.

Weight: 0.05 ounce, 1.3 grams

Available with 0.50 inch leads(P/N add suffix "S")

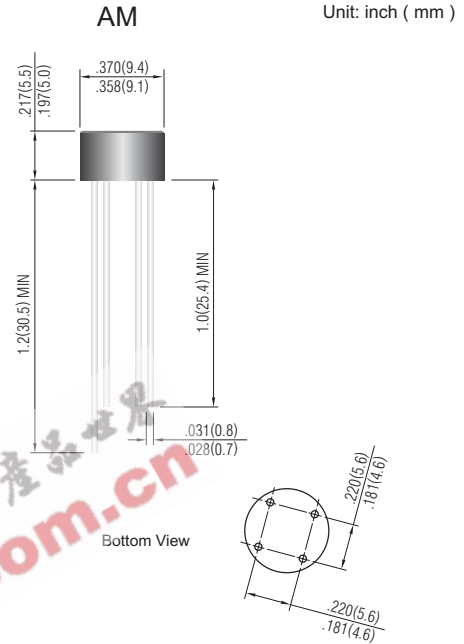

### MAXIMUM RATINGS AND ELECTRICAL CHARACTERISTICS

Rating at 25°C ambient temperature unless otherwise specified. Resistive or inductive load, 60Hz.  
For Capacitive load derate current by 20%.

	AM100	AM101	AM102	AM104	AM106	AM108	AM1010	UNITS
Maximum Recurrent Peak Reverse Voltage	50	100	200	400	600	800	1000	V
Maximum RMS Bridge input Voltage	35	70	140	280	420	560	700	V
Maximum DC Blocking Voltage	50	100	200	400	600	800	1000	V
Maximum Average Forward Current $T_A=50^\circ\text{C}$	1.0							A
Peak Forward Surge Current, 8.3ms singlehalf sine-wave superimposed on rated load	30.0							A
$I^2t$ Rating for fusing ( $t < 8.35$ ms)	10.0							$\text{A}^2\text{t}$
Maximum Forward Voltage Drop per Bridge Element at 1.0A	1.0							V
Maximum Reverse Current at Rated $T_J=25^\circ\text{C}$	10.0							$\mu\text{A}$
DC Blocking Voltage per element $T_J=125^\circ\text{C}$	1.0							mA
Typical Junction capacitance per leg (Note 1) $C_J$	24.0							pF
Typical Thermal resistance per leg (Note 2) $R_{\theta JA}$	36.0							$^\circ\text{C}/\text{W}$
Typical Thermal resistance per leg (Note 2) $R_{\theta JA}$	13.0							
Operating Temperature Range $T_J$	-55 to +125							$^\circ\text{C}$
Storage Temperature Range $T_A$	-55 to +150							$^\circ\text{C}$

#### NOTES:

1. Measured at 1.0 MHz and applied reverse voltage of 4.0 Volts.
2. Thermal resistance from junction to ambient and from junction to lead mounted on P.C.B. with 0.47 X 0.47"(12 X 12mm) copper pads.



RATING AND CHARACTERISTIC CURVES

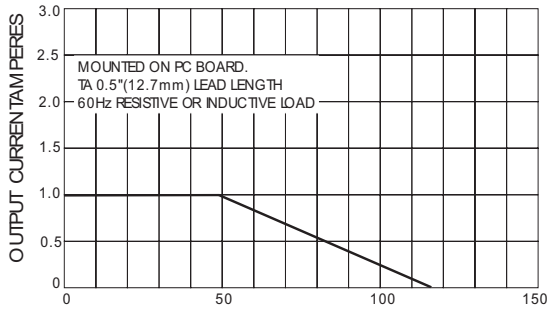

Fig. 1- DERATING CURVE FOR OUTPUT RECTIFIED CURRENT

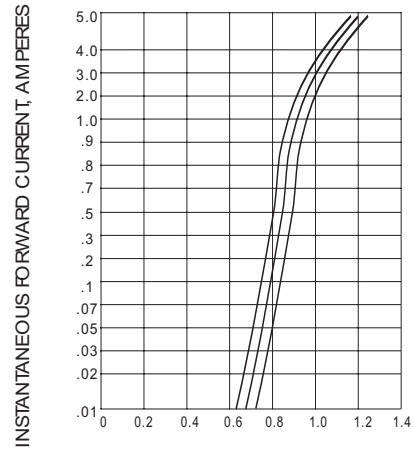

Fig. 2- TYPICAL INSTANTANEOUS FORWARD CHARACTERISTICS (25°C)

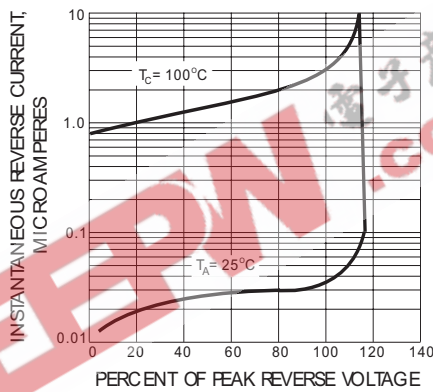

Fig. 3- TYPICAL REAK REVERSE CHARACTERISTICS

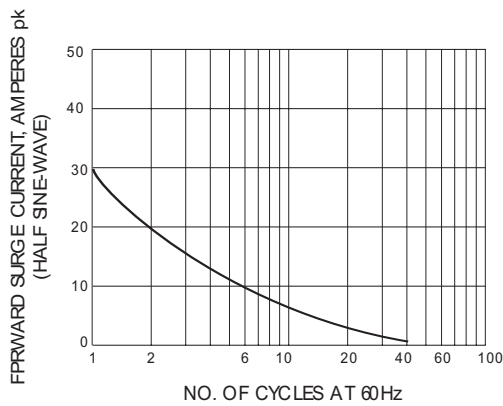

Fig. 4- MAXIMUM NON-REPETITIVE PEAK FORWARD SURGE CURRENT