

74ALVCH16245

Low-Voltage 16-Bit Transceiver with Bus Hold 1.8/2.5/3.3 V

(3-State, Non-Inverting)

The 74ALVCH16245 is an advanced performance, non-inverting 16-bit transceiver. It is designed for very high-speed, very low-power operation in 1.8 V, 2.5 V or 3.3 V systems.

The 74ALVCH16245 is designed with byte control. It can be operated as two separate octals, or with the controls tied together, as a 16-bit wide function. The Transmit/Receive (T/R_n) inputs determine the direction of data flow through the bi-directional transceiver. Transmit (active-HIGH) enables data from A ports to B ports; Receive (active-LOW) enables data from B to A ports. The Output Enable inputs (\overline{OE}_n), when HIGH, disable both A and B ports by placing them in a HIGH Z condition. The data inputs include active bushold circuitry, eliminating the need for external pull-up resistors to hold unused or floating inputs at a valid logic state.

- Designed for Low Voltage Operation: $V_{CC} = 1.65 - 3.6 V$
- 3.6 V Tolerant Inputs and Outputs
- High Speed Operation: 3.0 ns max for 3.0 to 3.6 V
3.7 ns max for 2.3 to 2.7 V
6.0 ns max for 1.65 to 1.95 V
- Static Drive: ± 24 mA Drive at 3.0 V
 ± 12 mA Drive at 2.3 V
 ± 4 mA Drive at 1.65 V
- Supports Live Insertion and Withdrawal
- Includes Active Bushold to Hold Unused or Floating Inputs at a Valid Logic State
- I_{OFF} Specification Guarantees High Impedance When $V_{CC} = 0 V^\dagger$
- Near Zero Static Supply Current in All Three Logic States (40 μA)
Substantially Reduces System Power Requirements
- Latchup Performance Exceeds ± 250 mA @ 125°C
- ESD Performance: Human Body Model >2000V; Machine Model >200V
- Second Source to Industry Standard 74ALVCH16245

† To ensure the outputs activate in the 3-state condition, the output enable pins should be connected to V_{CC} through a pull-up resistor. The value of the resistor is determined by the current sinking capability of the output connected to the OE pin.



ON Semiconductor®

<http://onsemi.com>

MARKING DIAGRAM

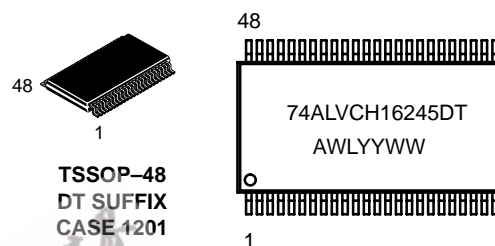

TSSOP-48
DT SUFFIX
CASE 1201

A = Assembly Location
WL = Wafer Lot
YY = Year
WW = Work Week

ORDERING INFORMATION

Device	Package	Shipping
74ALVCH16245DTR	TSSOP	2500/Tape & Reel

74ALVCH16245

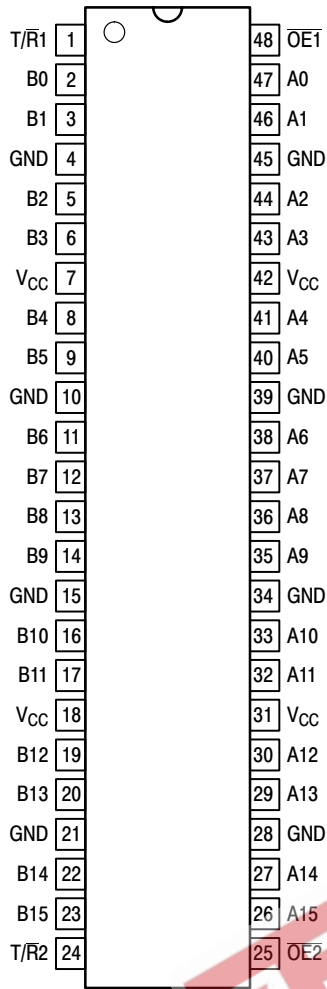

Figure 1. 48-Lead Pinout (Top View)

PIN NAMES

Pins	Function
$\overline{OE}n$	Output Enable Inputs
T/Rn	Transmit/Receive Inputs
A0–A15	Side A Inputs or 3-State Outputs
B0–B15	Side B Inputs or 3-State Outputs

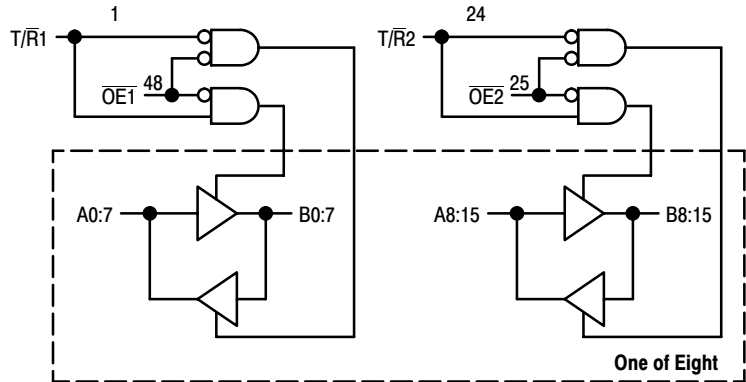

Figure 2. Logic Diagram

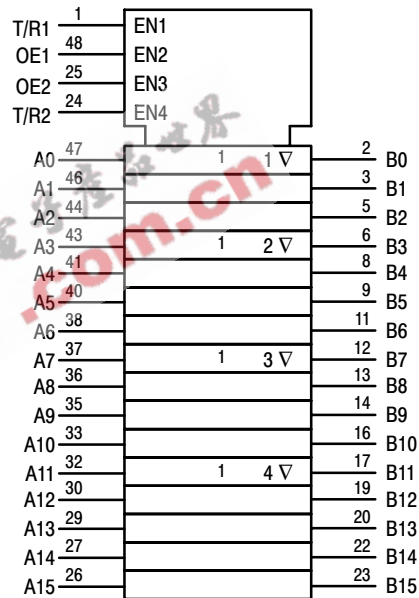

Figure 3. IEC Logic Diagram

Inputs		Outputs	Inputs		Outputs
OE1	T/R1		OE2	T/R2	
L	L	Bus B0:7 Data to Bus A0:7	L	L	Bus B8:15 Data to Bus A8:15
L	H	Bus A0:7 Data to Bus B0:7	L	H	Bus A8:15 Data to Bus B8:15
H	X	High Z State on A0:7, B0:7	H	X	High Z State on A8:15, B8:15

H = High Voltage Level; L = Low Voltage Level; X = High or Low Voltage Level and Transitions Are Acceptable

74ALVCH16245

MAXIMUM RATINGS (Note 1)

Symbol	Parameter	Value	Unit
V _{CC}	DC Supply Voltage	- 0.5 to + 4.6	V
V _I	DC Input Voltage	- 0.5 to + 4.6	V
V _O	DC Output Voltage	- 0.5 to + 4.6	V
I _{IK}	DC Input Diode Current V _I < GND	- 50	mA
I _{OK}	DC Output Diode Current V _O < GND	- 50	mA
I _O	DC Output Sink Current	± 50	mA
I _{CC}	DC Supply Current per Supply Pin	± 100	mA
I _{GND}	DC Ground Current per Ground Pin	± 100	mA
T _{STG}	Storage Temperature Range	- 65 to + 150	°C
T _L	Lead Temperature, 1 mm from Case for 10 Seconds	260	°C
T _J	Junction Temperature Under Bias	+ 150	°C
θ _{JA}	Thermal Resistance (Note 2)	90	°C/W
MSL	Moisture Sensitivity	Level 1	
F _R	Flammability Rating Oxygen Index: 30 to 35	UL 94 V-O @ 0.125 in	
V _{ESD}	ESD Withstand Voltage Human Body Model (Note 3) Machine Model (Note 4) Charged Device Model (Note 5)	> 2000 > 200 N/A	V
I _{LATCH-UP}	Latch-Up Performance Above V _{CC} and Below GND at 125°C (Note 6)	± 250	mA

Maximum Ratings are those values beyond which damage to the device may occur. Exposure to these conditions or conditions beyond those indicated may adversely affect device reliability. Functional operation under absolute maximum-rated conditions is not implied. Functional operation should be restricted to the Recommended Operating Conditions.

1. I_O absolute maximum rating must be observed.
2. Measured with minimum pad spacing on an FR4 board, using 10 mm-by-1 inch, 2-ounce copper trace with no air flow.
3. Tested to EIA/JESD22-A114-A.
4. Tested to EIA/JESD22-A115-A.
5. Tested to JESD22-C101-A.
6. Tested to EIA/JESD78.

RECOMMENDED OPERATING CONDITIONS

Symbol	Parameter	Min	Max	Unit
V _{CC}	Supply Voltage Operating Data Retention Only	2.3 1.5	3.6 3.6	V
V _I	Input Voltage (Note 7)	-0.5	3.6	V
V _O	Output Voltage (Active State) (3-State)	0 0	V _{CC} 3.6	V
T _A	Operating Free-Air Temperature	- 40	+ 85	°C
Δt/ΔV	Input Transition Rise or Fall Rate V _{CC} = 2.5 V ± 0.2 V V _{CC} = 3.0 V ± 0.3 V	0 0	20 10	ns/V

7. Unused inputs may not be left open. All inputs must be tied to a high-logic voltage level or a low-logic input voltage level.

74ALVCH16245

DC ELECTRICAL CHARACTERISTICS

Symbol	Parameter	Condition	T _A = -40°C to +85°C		Unit
			Min	Max	
V _{IH}	HIGH Level Input Voltage (Note 8)	1.65 V ≤ V _{CC} < 2.3 V	0.65 × V _{CC}		V
		2.3 V ≤ V _{CC} ≤ 2.7 V	1.7		
		2.7 V < V _{CC} ≤ 3.6 V	2.0		
V _{IL}	LOW Level Input Voltage (Note 8)	1.65 V ≤ V _{CC} < 2.3 V		0.35 × V _{CC}	V
		2.3 V ≤ V _{CC} ≤ 2.7 V		0.7	
		2.7 V < V _{CC} ≤ 3.6 V		0.8	
V _{OH}	HIGH Level Output Voltage	1.65 V ≤ V _{CC} ≤ 3.6 V; I _{OH} = -100 μA	V _{CC} - 0.2		V
		V _{CC} = 1.65 V; I _{OH} = -4 mA	1.2		
		V _{CC} = 2.3 V; I _{OH} = -6 mA	2.0		
		V _{CC} = 2.3 V; I _{OH} = -12 mA	1.7		
		V _{CC} = 2.7 V; I _{OH} = -12 mA	2.2		
		V _{CC} = 3.0 V; I _{OH} = -12 mA	2.4		
		V _{CC} = 3.0 V; I _{OH} = -24 mA	2.0		
V _{OL}	LOW Level Output Voltage	1.65 V ≤ V _{CC} ≤ 3.6 V; I _{OL} = 100 μA		0.2	V
		V _{CC} = 1.65 V; I _{OL} = 4 mA		0.45	
		V _{CC} = 2.3 V; I _{OL} = 6 mA		0.4	
		V _{CC} = 2.3 V; I _{OL} = 12 mA		0.7	
		V _{CC} = 2.7 V; I _{OL} = 12 mA		0.4	
		V _{CC} = 3.0 V; I _{OL} = 24 mA		0.55	
I _I	Input Leakage Current	1.65 V ≤ V _{CC} ≤ 3.6 V; 0 V ≤ V _I ≤ 3.6 V		± 5.0	μA
I _{I(HOLD)}	Minimum Bus-hold Input Current	V _{CC} = 3.6 V; V _{IN} = 0 to 3.6 V		± 500	μA
		V _{CC} = 3.0 V, V _{IN} = 0.8 V	75		
		V _{CC} = 3.0 V, V _{IN} = 2.0 V	-75		
		V _{CC} = 2.3 V, V _{IN} = 0.7 V	45		
		V _{CC} = 2.3 V, V _{IN} = 1.7 V	-45		
		V _{CC} = 1.65 V, V _{IN} = 0.58 V	25		
		V _{CC} = 1.65 V, V _{IN} = 1.07 V	-25		
I _{OZ}	3-State Output Current	1.65 V ≤ V _{CC} ≤ 3.6 V; 0 V ≤ V _O ≤ 3.6 V; V _I = V _{IH} or V _{IL}		± 10	μA
I _{OFF}	Power-Off Leakage Current	V _{CC} = 0 V; V _I or V _O = 3.6 V		10	μA
I _{CC}	Quiescent Supply Current (Note 9)	1.65 V ≤ V _{CC} ≤ 3.6 V; V _I = GND or V _{CC}		40	μA
		1.65 V ≤ V _{CC} ≤ 3.6 V; 3.6 V ≤ V _I , V _O ≤ 3.6 V		± 40	
ΔI _{CC}	Increase in I _{CC} per Input	2.7 V < V _{CC} ≤ 3.6 V; V _{IH} = V _{CC} - 0.6 V		750	μA

8. These values of V_I are used to test DC electrical characteristics only.

9. Outputs disabled or 3-state only.

74ALVCH16245

AC CHARACTERISTICS (Note 10; $t_R = t_F = 2.0$ ns; $C_L = 30$ pF; $R_L = 500 \Omega$)

Symbol	Parameter	Waveform	Limits						Unit
			$T_A = -40^\circ\text{C to } +85^\circ\text{C}$						
			$V_{CC} = 3.0$ V to 3.6 V		$V_{CC} = 2.3$ V to 2.7 V		$V_{CC} = 1.65$ V to 1.95 V		
			Min	Max	Min	Max	Min	Max	
t_{PLH} t_{PHL}	Propagation Delay Input to Output	1	1.0 1.0	3.0 3.0	1.0 1.0	3.7 3.7	1.0 1.0	6.0 6.0	ns
t_{PZH} t_{PZL}	Output Enable Time to High and Low Level	2	1.0 1.0	4.4 4.4	1.0 1.0	5.7 5.7	1.0 1.0	9.3 9.3	ns
t_{PHZ} t_{PLZ}	Output Disable Time From High and Low Level	2	1.0 1.0	4.1 4.1	1.0 1.0	5.2 5.2	1.0 1.0	7.6 7.6	ns
t_{OSHL} t_{OSLH}	Output-to-Output Skew (Note 11)			0.5 0.5		0.5 0.5		0.75 0.75	ns

10. For $C_L = 50$ pF, add approximately 300 ps to the AC maximum specification.

11. Skew is defined as the absolute value of the difference between the actual propagation delay for any two separate outputs of the same device. The specification applies to any outputs switching in the same direction, either HIGH-to-LOW (t_{OSHL}) or LOW-to-HIGH (t_{OSLH}); parameter guaranteed by design.

CAPACITIVE CHARACTERISTICS

Symbol	Parameter	Condition	Typical	Unit
C_{IN}	Input Capacitance	Note 12	6	pF
C_{OUT}	Output Capacitance	Note 12	7	pF
C_{PD}	Power Dissipation Capacitance	Note 12, 10MHz	20	pF

12. $V_{CC} = 1.8, 2.5$ or 3.3 V; $V_I = 0$ V or V_{CC} .

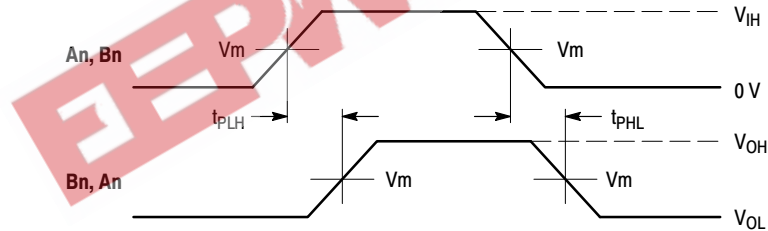

WAVEFORM 1 - PROPAGATION DELAYS

$t_R = t_F = 2.0$ ns, 10% to 90%; $f = 1$ MHz; $t_W = 500$ ns

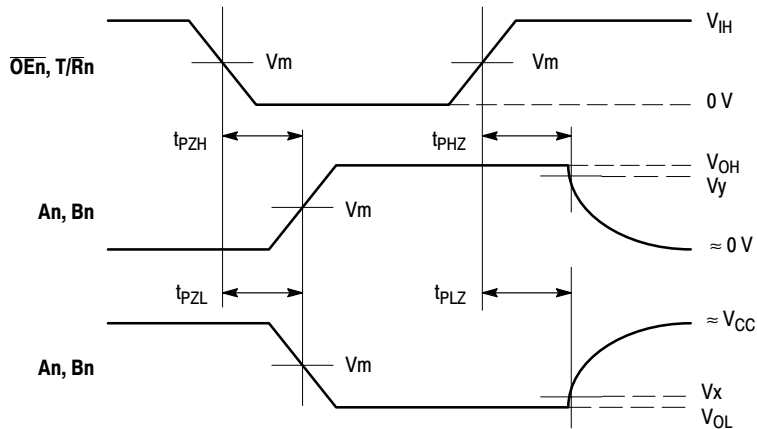

WAVEFORM 2 - OUTPUT ENABLE AND DISABLE TIMES

$t_R = t_F = 2.0$ ns, 10% to 90%; $f = 1$ MHz; $t_W = 500$ ns

Figure 4. AC Waveforms

74ALVCH16245

Symbol	V _{CC}		
	3.3 V ±0.3 V	2.5 V ±0.2 V	1.8 V ±0.15 V
V _{IH}	2.7 V	V _{CC}	V _{CC}
V _m	1.5 V	V _{CC} /2	V _{CC} /2
V _x	V _{OL} + 0.3 V	V _{OL} + 0.15 V	V _{OL} + 0.15 V
V _y	V _{OH} - 0.3 V	V _{OH} - 0.15 V	V _{OH} - 0.15 V

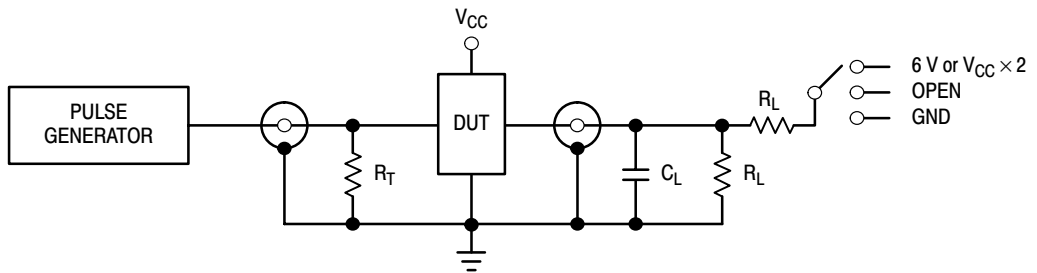

TEST	SWITCH
t _{PLH} , t _{PHL}	Open
t _{PZL} , t _{PLZ}	6 V at V _{CC} = 3.3 ±0.3 V; V _{CC} × 2 at V _{CC} = 2.5 ±0.2 V; 1.8 V ±0.15 V
t _{PZH} , t _{PHZ}	GND

$C_L = 50 \text{ pF}$ for $V_{CC} = 3.0 \pm 0.3 \text{ V}$
 $R_L = 500 \Omega$ or equivalent
 $R_T = Z_{OUT}$ of pulse generator (typically 50Ω)

Figure 5. Test Circuit

74ALVCH16245

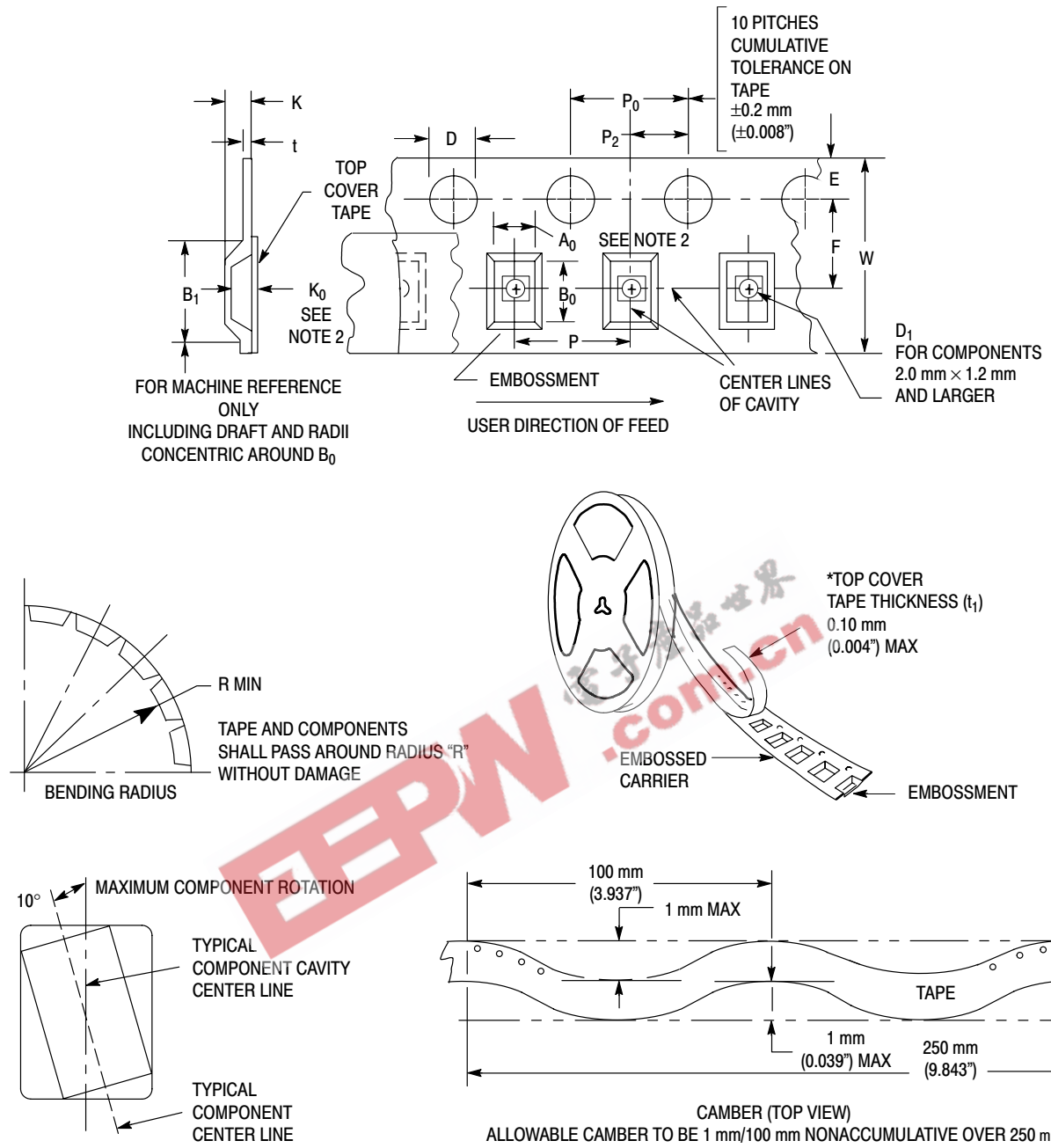

Figure 6. Carrier Tape Specifications

EMBOSSED CARRIER DIMENSIONS (See Notes 13 and 14)

Tape Size	B ₁ Max	D	D ₁	E	F	K	P	P ₀	P ₂	R	T	W
24mm	20.1mm (0.791")	1.5 + 0.1mm -0.0 (0.059 +0.004" -0.0)	1.5mm Min (0.060")	1.75 ±0.1 mm (0.069 ±0.004")	11.5 ±0.10 mm (0.453 ±0.004")	11.9 mm Max (0.468")	16.0 ±0.1 mm (0.63 ±0.004")	4.0 ±0.1 mm (0.157 ±0.004")	2.0 ±0.1 mm (0.079 ±0.004")	30 mm (1.18")	0.6 mm (0.024")	24.3 mm (0.957")

13. Metric Dimensions Govern—English are in parentheses for reference only.

14. A₀, B₀, and K₀ are determined by component size. The clearance between the components and the cavity must be within 0.05 mm min to 0.50 mm max. The component cannot rotate more than 10° within the determined cavity.

74ALVCH16245

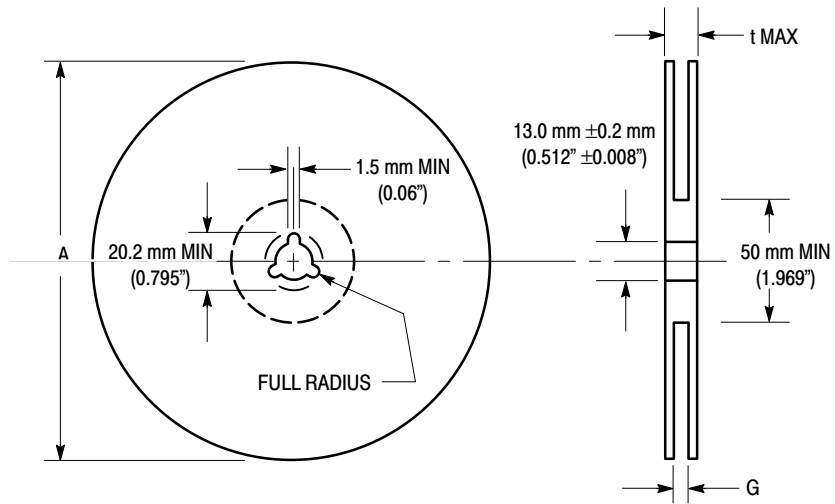

Figure 7. Reel Dimensions

REEL DIMENSIONS

Tape Size	A Max	G	t Max
24 mm	360 mm (14.173")	24.4 mm + 2.0 mm, -0.0 (0.961" + 0.078", -0.00)	30.4 mm (1.197")

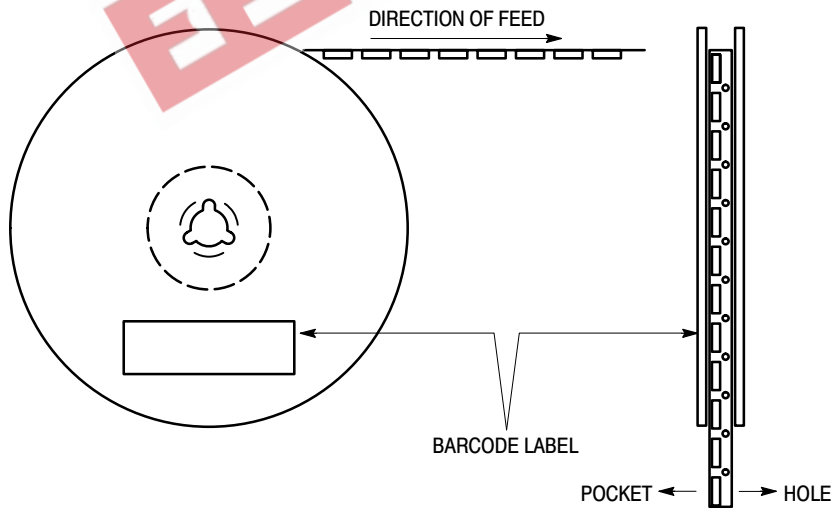

Figure 8. Reel Winding Direction

74ALVCH16245

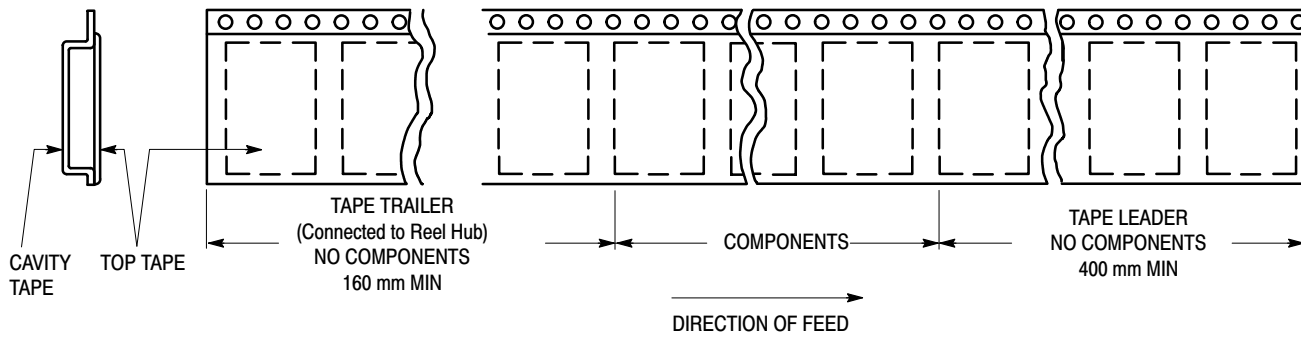

Figure 9. Tape Ends for Finished Goods

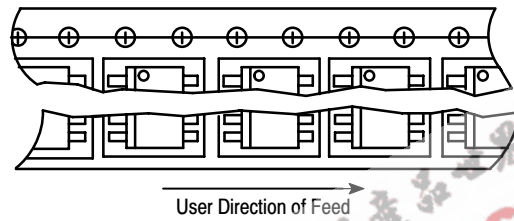

Figure 10. Reel Configuration

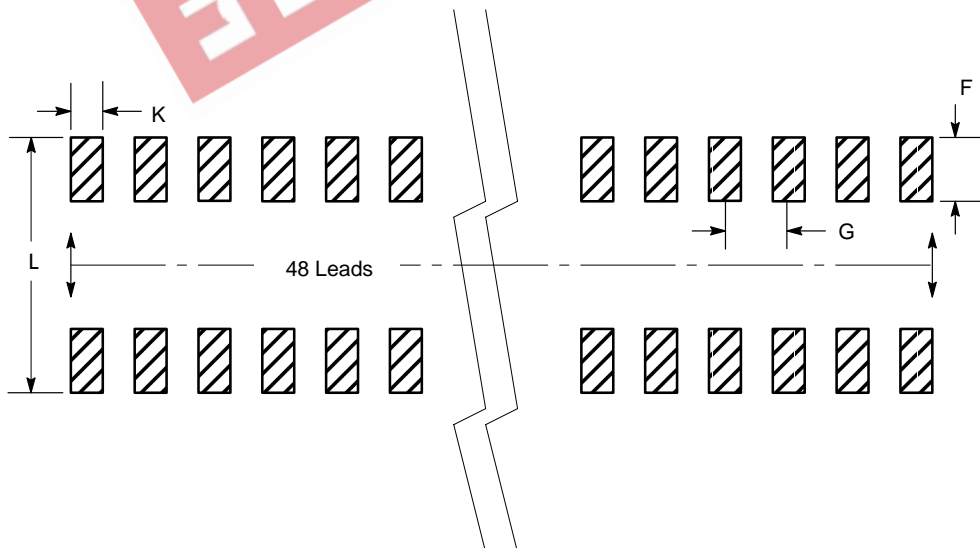
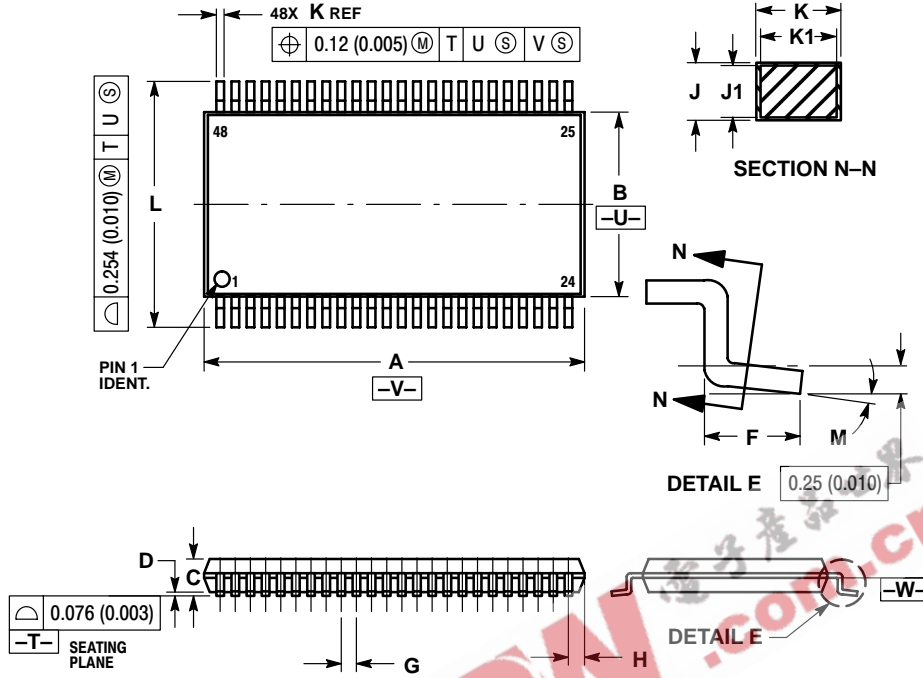

Figure 11. Package Footprint

74ALVCH16245

PACKAGE DIMENSIONS

TSSOP
DT SUFFIX
CASE 1201-01
ISSUE A



NOTES:

1. DIMENSIONING AND TOLERANCING PER ANSI Y14.5M, 1982.
2. CONTROLLING DIMENSION: MILLIMETER.
3. DIMENSIONS A AND B DO NOT INCLUDE MOLD FLASH, PROTRUSIONS OR GATE BURRS. MOLD FLASH OR GATE BURRS SHALL NOT EXCEED 0.15 (0.006) PER SIDE.
4. DIMENSION K DOES NOT INCLUDE DAMBAR PROTRUSION. ALLOWABLE DAMBAR PROTRUSION SHALL BE 0.08 (0.003) TOTAL IN EXCESS OF THE K DIMENSION AT MAXIMUM MATERIAL CONDITION.
5. TERMINAL NUMBERS ARE SHOWN FOR REFERENCE ONLY.
6. DIMENSIONS A AND B ARE TO BE DETERMINED AT DATUM PLANE -W-.

DIM	MILLIMETERS		INCHES	
	MIN	MAX	MIN	MAX
A	12.40	12.60	0.488	0.496
B	6.00	6.20	0.236	0.244
C	---	1.10	---	0.043
D	0.05	0.15	0.002	0.006
F	0.50	0.75	0.020	0.030
G	0.50 BSC		0.0197 BSC	
H	0.37	---	0.015	---
J	0.09	0.20	0.004	0.008
J1	0.09	0.16	0.004	0.006
K	0.17	0.27	0.007	0.011
K1	0.17	0.23	0.007	0.009
L	7.95	8.25	0.313	0.325
M	0°		8°	

Notes

EEPW 电子产品世界
.com.cn

74ALVCH16245

EEPW 电子產品世界
.com.cn

ON Semiconductor and  are registered trademarks of Semiconductor Components Industries, LLC (SCILLC). SCILLC reserves the right to make changes without further notice to any products herein. SCILLC makes no warranty, representation or guarantee regarding the suitability of its products for any particular purpose, nor does SCILLC assume any liability arising out of the application or use of any product or circuit, and specifically disclaims any and all liability, including without limitation special, consequential or incidental damages. "Typical" parameters which may be provided in SCILLC data sheets and/or specifications can and do vary in different applications and actual performance may vary over time. All operating parameters, including "Typicals" must be validated for each customer application by customer's technical experts. SCILLC does not convey any license under its patent rights nor the rights of others. SCILLC products are not designed, intended, or authorized for use as components in systems intended for surgical implant into the body, or other applications intended to support or sustain life, or for any other application in which the failure of the SCILLC product could create a situation where personal injury or death may occur. Should Buyer purchase or use SCILLC products for any such unintended or unauthorized application, Buyer shall indemnify and hold SCILLC and its officers, employees, subsidiaries, affiliates, and distributors harmless against all claims, costs, damages, and expenses, and reasonable attorney fees arising out of, directly or indirectly, any claim of personal injury or death associated with such unintended or unauthorized use, even if such claim alleges that SCILLC was negligent regarding the design or manufacture of the part. SCILLC is an Equal Opportunity/Affirmative Action Employer.

PUBLICATION ORDERING INFORMATION

Literature Fulfillment:

Literature Distribution Center for ON Semiconductor
P.O. Box 5163, Denver, Colorado 80217 USA
Phone: 303-675-2175 or 800-344-3860 Toll Free USA/Canada
Fax: 303-675-2176 or 800-344-3867 Toll Free USA/Canada
Email: ONlit@hibbertco.com

N. American Technical Support: 800-282-9855 Toll Free USA/Canada

JAPAN: ON Semiconductor, Japan Customer Focus Center
2-9-1 Kamimeguro, Meguro-ku, Tokyo, Japan 153-0051

Phone: 81-3-5773-3850

Email: r14525@onsemi.com

ON Semiconductor Website: <http://onsemi.com>

For additional information, please contact your local
Sales Representative.

74ALVCH16245/D