

54LS352/DM74LS352 Dual 4-Line to 1-Line Data Selectors/Multiplexers

General Description

Each of these data selectors/multiplexers contains inverters and drivers to supply fully complementary, on-chip, binary decoding data selection to the AND-OR-invert gates. Separate strobe inputs are provided for each of the two four-line sections.

- Performs parallel-to-serial conversion
- Strobe (enable) line provided for cascading (N lines to n lines)
- High fan-out, low-impedance, totem-pole outputs
- Typical average propagation delay times
 - From data 15 ns
 - From strobe 19 ns
 - From select 22 ns
- Typical power dissipation 31 mW

Features

- Inverting version of DM54/74LS153
- Permits multiplexing from N lines to 1 line

Connection Diagram

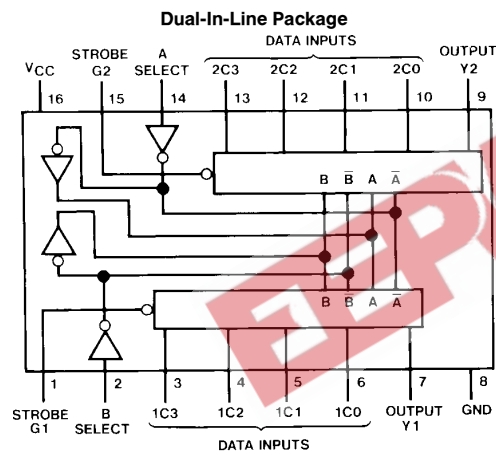

Function Table

Select Inputs		Data Inputs				Strobe	Output
B	A	C0	C1	C2	C3	G	Y
X	X	X	X	X	X	H	H
L	L	L	X	X	X	L	H
L	L	H	X	X	X	L	L
L	H	X	L	X	X	L	H
L	H	X	H	X	X	L	L
H	L	X	X	L	X	L	H
H	L	X	X	H	X	L	L
H	H	X	X	X	L	L	H
H	H	X	X	X	H	L	L

Select inputs A and B are common to both sections.
H = High Level, L = Low Level, X = Don't Care

TL/F/6425-1

Order Number 54LS352DMQB, 54LS352FMQB,
DM74LS352M or DM74LS352N
See NS Package Number J16A, M16A, N16E or W16A

Absolute Maximum Ratings (Note)

If Military/Aerospace specified devices are required, please contact the National Semiconductor Sales Office/Distributors for availability and specifications.

Supply Voltage	7V
Input Voltage	7V
Operating Free Air Temperature Range	
54LS	−55° C to +125° C
DM74LS	0° C to +70° C
Storage Temperature Range	−65° C to +150° C

Note: The "Absolute Maximum Ratings" are those values beyond which the safety of the device cannot be guaranteed. The device should not be operated at these limits. The parametric values defined in the "Electrical Characteristics" table are not guaranteed at the absolute maximum ratings. The "Recommended Operating Conditions" table will define the conditions for actual device operation.

Recommended Operating Conditions

Symbol	Parameter	54LS352			DM74LS352			Units
		Min	Nom	Max	Min	Nom	Max	
V _{CC}	Supply Voltage	4.5	5	5.5	4.75	5	5.25	V
V _{IH}	High Level Input Voltage	2			2			V
V _{IL}	Low Level Input Voltage			0.7			0.8	V
I _{OH}	High Level Output Current			−0.4			−0.4	mA
I _{OL}	Low Level Output Current			12			8	mA
T _A	Free Air Operating Temperature	−55		125	0		70	°C

Electrical Characteristics over recommended operating free air temperature range (unless otherwise noted)

Symbol	Parameter	Conditions	Min	Typ (Note 1)	Max	Units	
							V _I
V _{OH}	High Level Output Voltage	V _{CC} = Min, I _{OH} = Max V _{IL} = Max, V _{IH} = Min	54LS DM74	2.5 2.7	3.4	V	
V _{OL}	Low Level Output Voltage	V _{CC} = Min, I _{OL} = Max V _{IL} = Max, V _{IH} = Min	54LS DM74		0.4 0.35	V	
		I _{OL} = 4 mA V _{CC} = Min	DM74		0.25	0.4	
I _I	Input Current @ Max Input Voltage	V _{CC} = Max, V _I = 10V V _{CC} = Max, V _I = 7V	54LS DM74			0.1	mA
I _{IH}	High Level Input Current	V _{CC} = Max, V _I = 2.7V				20	μA
I _{IL}	Low Level Input Current	V _{CC} = Max, V _I = 0.4V				−0.4	mA
I _{OS}	Short Circuit Output Current	V _{CC} = Max (Note 2)	54LS DM74	−20 −20		−100 −100	mA
I _{CC}	Supply Current	V _{CC} = Max (Note 3)			6.2	10	mA

Note 1: All typicals are at V_{CC} = 5V, T_A = 25°C.

Note 2: Not more than one output should be shorted at a time, and the duration should not exceed one second.

Note 3: I_{CC} is measured with all outputs open and all other inputs at ground.

Switching Characteristics at $V_{CC} = 5V$ and $T_A = 25^\circ C$ (See Section 1 for Test Waveforms and Output Load)

Symbol	Parameter	From (Input) To (Output)	54LS		DM74LS		Units
			$C_L = 15\text{ pF}$		$C_L = 50\text{ pF}$ $R_L = 2\text{ k}\Omega$		
			Min	Max	Min	Max	
t_{PLH}	Propagation Delay Time Low to High Level Output	Data to Y		12		24	ns
t_{PHL}	Propagation Delay Time High to Low Level Output	Data to Y		12		35	ns
t_{PLH}	Propagation Delay Time Low to High Level Output	Select to Y		22		33	ns
t_{PHL}	Propagation Delay Time High to Low Level Output	Select to Y		38		47	ns
t_{PLH}	Propagation Delay Time Low to High Level Output	Strobe to Y		15		29	ns
t_{PHL}	Propagation Delay Time High to Low Level Output	Strobe to Y		20		41	ns

Logic Diagram

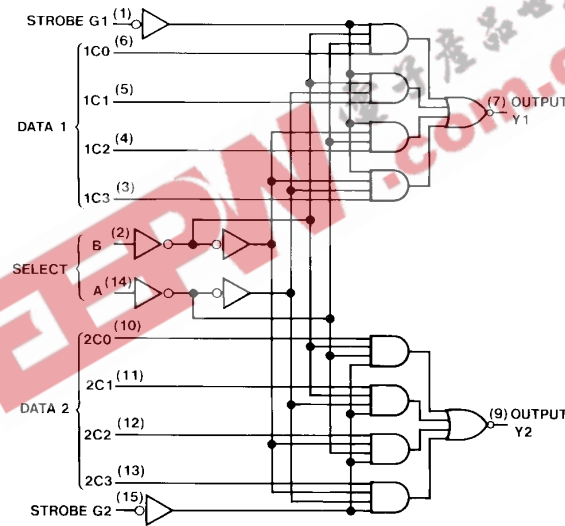

TL/F/6425-2

Physical Dimensions inches (millimeters)

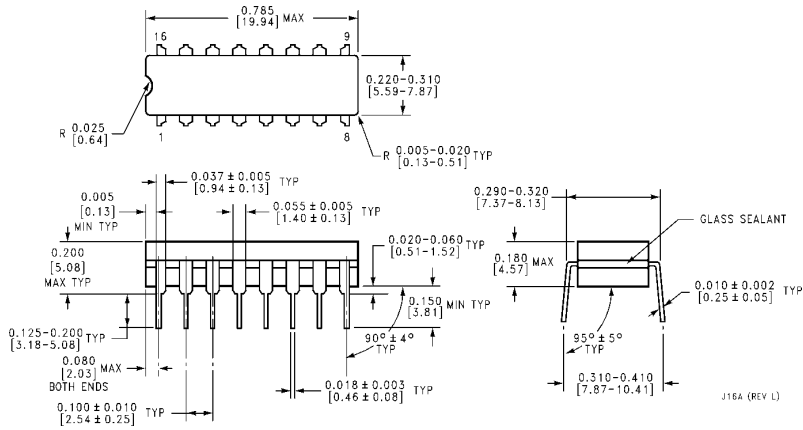

16-Lead Ceramic Dual-In-Line Package (J)
Order Number 54LS352DMQB
NS Package Number J16A

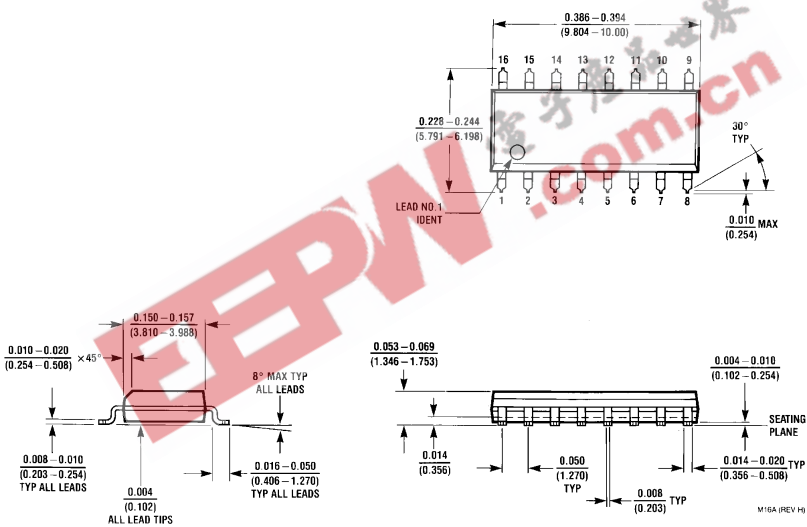

16-Lead Small Outline Molded Package (M)
Order Number DM74LS352M
NS Package Number M16A

Physical Dimensions inches (millimeters) (Continued)

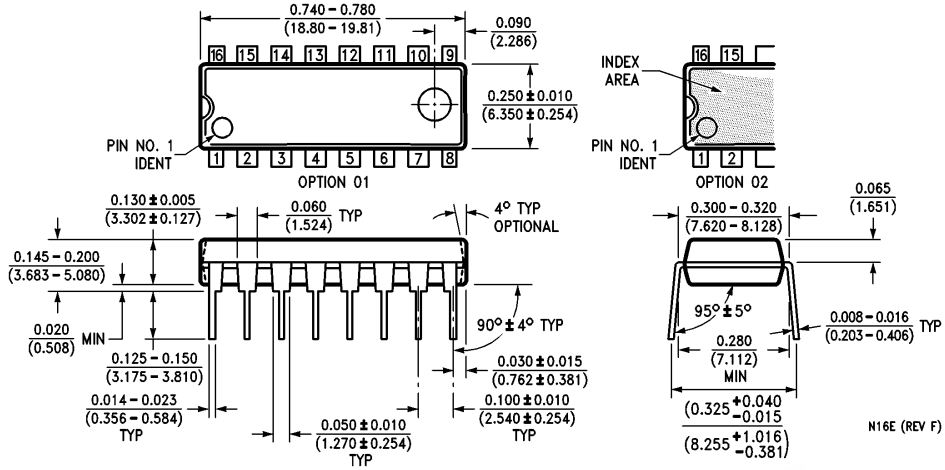

16-Lead Molded Dual-In-Line Package (N)
Order Number DM74LS352N
NS Package Number N16E

EEPW.com.cn 电子产品世界

N16E (REV F)

Physical Dimensions inches (millimeters) (Continued)

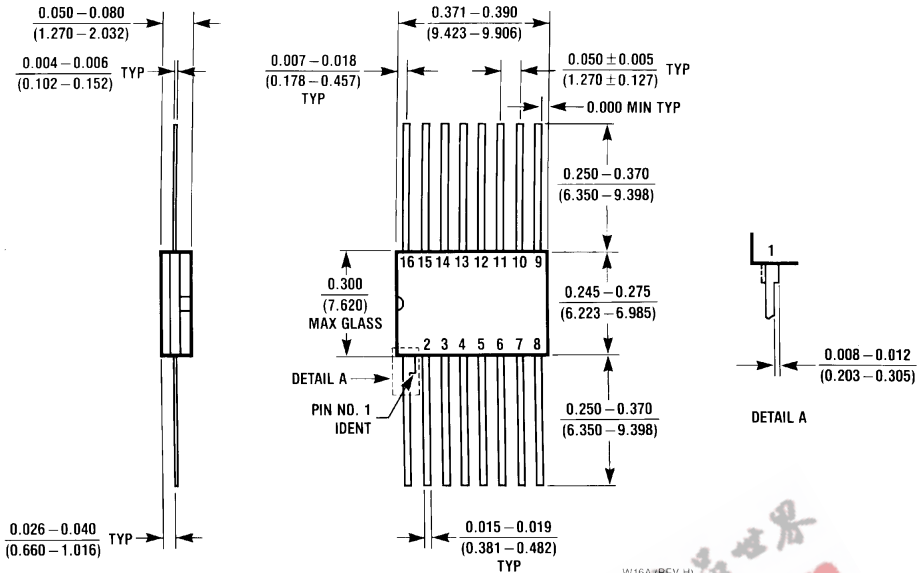

16-Lead Ceramic Flat Package (W)
Order Number 54LS352FMB
NS Package Number W16A

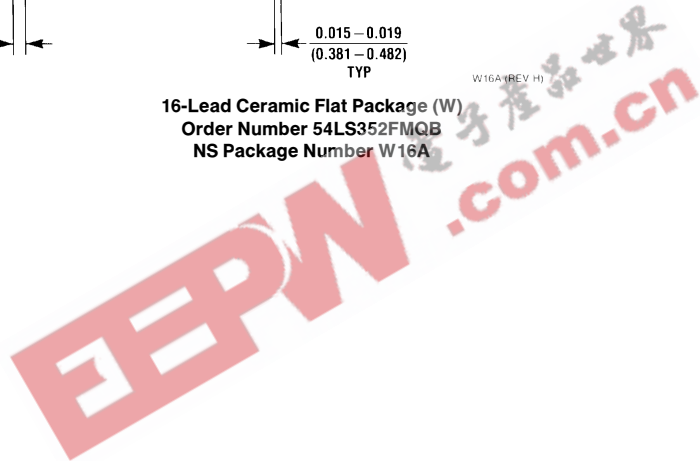

LIFE SUPPORT POLICY

NATIONAL'S PRODUCTS ARE NOT AUTHORIZED FOR USE AS CRITICAL COMPONENTS IN LIFE SUPPORT DEVICES OR SYSTEMS WITHOUT THE EXPRESS WRITTEN APPROVAL OF THE PRESIDENT OF NATIONAL SEMICONDUCTOR CORPORATION. As used herein:

1. Life support devices or systems are devices or systems which, (a) are intended for surgical implant into the body, or (b) support or sustain life, and whose failure to perform, when properly used in accordance with instructions for use provided in the labeling, can be reasonably expected to result in a significant injury to the user.
2. A critical component is any component of a life support device or system whose failure to perform can be reasonably expected to cause the failure of the life support device or system, or to affect its safety or effectiveness.



National Semiconductor Corporation
 1111 West Bardin Road
 Arlington, TX 76017
 Tel: 1(800) 272-9959
 Fax: 1(800) 737-7018

National Semiconductor Europe
 Fax: (+49) 0-180-530 85 86
 Email: cnjwge@levm2.nsc.com
 Deutsch Tel: (+49) 0-180-530 85 85
 English Tel: (+49) 0-180-532 78 32
 Français Tel: (+49) 0-180-532 93 58
 Italiano Tel: (+49) 0-180-534 16 80

National Semiconductor Hong Kong Ltd.
 13th Floor, Straight Block,
 Ocean Centre, 5 Canton Rd.
 Tsimshatsui, Kowloon
 Hong Kong
 Tel: (852) 2737-1600
 Fax: (852) 2736-9960

National Semiconductor Japan Ltd.
 Tel: 81-043-299-2309
 Fax: 81-043-299-2408

National does not assume any responsibility for use of any circuitry described, no circuit patent licenses are implied and National reserves the right at any time without notice to change said circuitry and specifications.