

AM1D-N Series

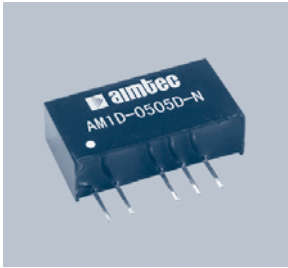

1 watt dc-dc converters

- 7PIN SIP PACKAGE
- LOW RIPPLE & NOISE
- HIGH EFFICIENCY UP TO 81%
- UL94-VO PACKAGE
- INPUT/OUTPUT ISOLATION: 1000, 3000 & 6000VDC
- OPERATING TEMPERATURE: -40°C ... +85°C
- PIN-COMPATIBLE WITH MULTIPLE MANUFACTURERS

GENERAL DESCRIPTION

Our AM1D-N series is a family of cost effective 1W single, dual output isolated DC-DC converters. These converters achieve low cost and ultra-miniature SIP7 pin size without compromising performance and reliability.

Seventy two models operate from input voltages of 5, 12 & 24VDC; producing output voltage levels of 5, 9, 12, 15, ± 5 , ± 9 , ± 12 , ± 15 VDC. Full SMD-design and a 100% production test of parameters ensures a high reliability in this product.

ELECTRICAL SPECIFICATIONS

Specifications typical at +25°C, nominal input voltage, rated output current unless otherwise specified

Input Specifications:		General Specifications:	
Voltage range	$\pm 10\%$	Efficiency	72% to 81%
Filter	Capacitor	Switching frequency	150KHz, typ. 100% load
Isolation Specifications:		Environmental Specifications:	
Rated voltage (60 sec)	1000, 3000 & 6000VDC	Operating temperature (ambient)	-40°C ... +85°C
Resistance	> 1000M Ω hm	Storage temperature	-55°C ... +125°C
Capacitance	60pF, typ.	Case Temperature	+95°C, max.
Output Specifications:		Derating	None required
Voltage balance (dual output)	$\pm 1\%$	Humidity (non-condensing)	Up to 90%
Voltage accuracy	$\pm 5\%$, max.	Cooling	Free-air Convection
Ripple & noise (at 20MHz BW)	75mVp-p, typ.	Physical Specifications:	
Short circuit protection	1 sec.	Dimensions (1000 & 3000VDC)	19.50x6.00x10.00mm
Line voltage regulation	$\pm 1.2\%$ / 1.0% of V_{in}		0.76x0.24x0.39inches
Load voltage regulation	10% max.	Dimensions (6000VDC)	19.50x9.8x12.5mm
	load=10~100%		0.76x0.39x0.49inches
Temperature coefficient	$\pm 0.03\%/^{\circ}\text{C}$, max.	Weight	2g
		Case material	Plastic UL94-VO

MTBF: > 1,100,000 hrs (MIL-HDBK-217F, Ground Benign, $t=+25^{\circ}\text{C}$)

Specifications are subject to change without notification

PIN CONNECTIONS

Pin	1000VDC		3000, 6000VDC	
	Single	Dual	Single	Dual
1	+V Input	+V Input	+V Input	+V Input
2	-V Input	-V Input	-V Input	-V Input
4	-V Output	-V Output	Omitted	Omitted
5	Omitted	Common	-V Output	-V Output
6	+V Output	+V Output	Omitted	Common
7	Omitted	Omitted	+V Output	+V Output

Continued on next page

AM1D-N Series

OUTLINE DIMENSIONS

1000 & 3000VDC

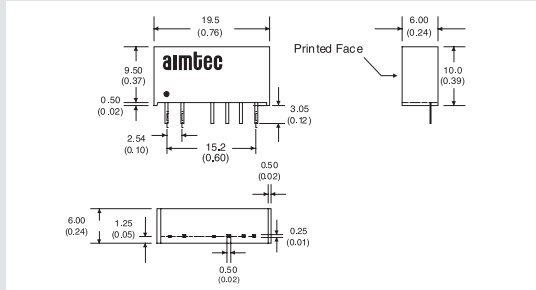

6000VDC

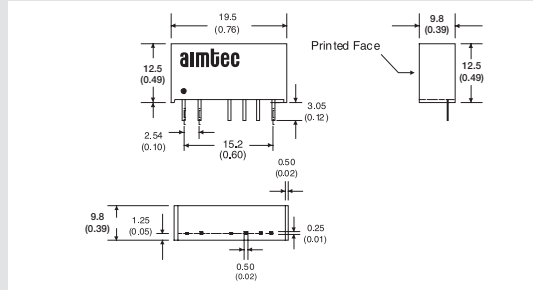

MODELS

Single output

Models			Input Voltage	Output Voltage	Output Current max.
Isolation 1000VDC	Isolation 3000VDC	Isolation 6000VDC			
AM1D-0505S-N	AM1D-0505SH30-N	AM1D-0505SH60-N	5V±10%	5VDC	200mA
AM1D-0509S-N	AM1D-0509SH30-N	AM1D-0509SH60-N		9VDC	110mA
AM1D-0512S-N	AM1D-0512SH30-N	AM1D-0512SH60-N		12VDC	83mA
AM1D-0515S-N	AM1D-0515SH30-N	AM1D-0515SH60-N		15VDC	70mA
AM1D-1205S-N	AM1D-1205SH30-N	AM1D-1205SH60-N	12V±10%	5VDC	200mA
AM1D-1209S-N	AM1D-1209SH30-N	AM1D-1209SH60-N		9VDC	110mA
AM1D-1212S-N	AM1D-1212SH30-N	AM1D-1212SH60-N		12VDC	83mA
AM1D-1215S-N	AM1D-1215SH30-N	AM1D-1215SH60-N		15VDC	70mA
AM1D-2405S-N	AM1D-2405SH30-N	AM1D-2405SH60-N	24V±10%	5VDC	200mA
AM1D-2409S-N	AM1D-2409SH30-N	AM1D-2409SH60-N		9VDC	110mA
AM1D-2412S-N	AM1D-2412SH30-N	AM1D-2412SH60-N		12VDC	83mA
AM1D-2415S-N	AM1D-2415SH30-N	AM1D-2415SH60-N		15VDC	70mA

Dual output

Models			Input Voltage	Output Voltage	Output Current max.
Isolation 1000VDC	Isolation 3000VDC	Isolation 6000VDC			
AM1D-0505D-N	AM1D-0505DH30-N	AM1D-0505DH60-N	5V±10%	±5VDC	±100mA
AM1D-0509D-N	AM1D-0509DH30-N	AM1D-0509DH60-N		±9VDC	±55mA
AM1D-0512D-N	AM1D-0512DH30-N	AM1D-0512DH60-N		±12VDC	±42mA
AM1D-0515D-N	AM1D-0515DH30-N	AM1D-0515DH60-N		±15VDC	±35mA
AM1D-1205D-N	AM1D-1205DH30-N	AM1D-1205DH60-N	12V±10%	±5VDC	±100mA
AM1D-1209D-N	AM1D-1209DH30-N	AM1D-1209DH60-N		±9VDC	±55mA
AM1D-1212D-N	AM1D-1212DH30-N	AM1D-1212DH60-N		±12VDC	±42mA
AM1D-1215D-N	AM1D-1215DH30-N	AM1D-1215DH60-N		±15VDC	±35mA
AM1D-2405D-N	AM1D-2405DH30-N	AM1D-2405DH60-N	24V±10%	±5VDC	±100mA
AM1D-2409D-N	AM1D-2409DH30-N	AM1D-2409DH60-N		±9VDC	±55mA
AM1D-2412D-N	AM1D-2412DH30-N	AM1D-2412DH60-N		±12VDC	±42mA
AM1D-2415D-N	AM1D-2415DH30-N	AM1D-2415DH60-N		±15VDC	±35mA

AM1D-N Series

TYPICAL CHARACTERISTICS

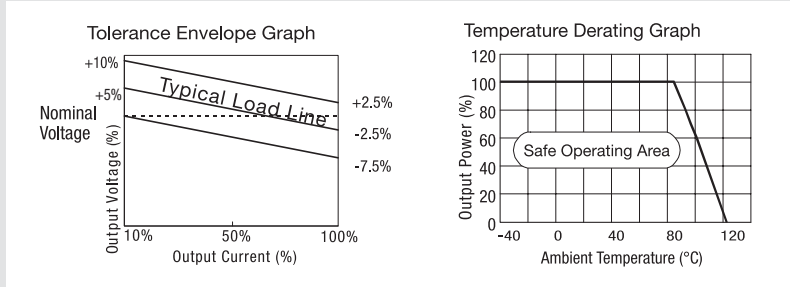

APPLICATION NOTE

Filtering

In some circuits which are sensitive to noise and ripple, a filtering capacitor may be added to the DC/DC output end and input end to reduce the noise and ripple. However, the capacitance of the output filter capacitor must be proper. If the capacitance is too big, a startup problem might arise. For every channel of output, provided the safe and reliable operation is ensured, the greatest capacitance of its filter capacitor sees the external capacitor table. To get an extremely low ripple, an "LC" filtering network may be connected to the input and output ends of the DC/DC converter, which may produce a more significant filtering effect. It should also be noted that the inductance and the frequency of the "LC" filtering network should be staggered with the dc/dc frequency to avoid mutual interference (see figure 1).

Requirement on output load

To ensure this module can operate efficiently and reliably, a minimum load is specified for this kind of DC/DC converter in addition to a maximum load (namely full load). During operation, make sure the specified range of input voltage is not exceeded, the minimum output load is not less than 10% of the full load, and that this product should never be operated under no load! If the actual output power is very small, please connect a resistor with proper resistance at the output end in parallel to increase the load.

For single output

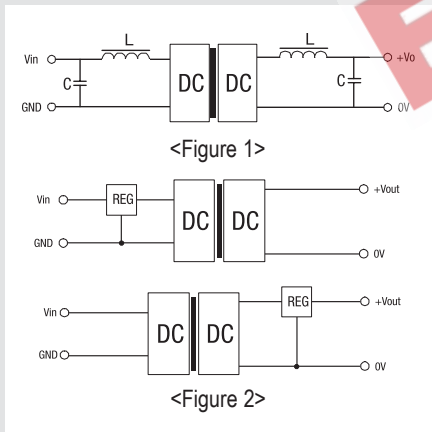

Overload Protection

Under normal operating conditions, the output circuit of these products has no protection against over-current and short-circuits. The simplest method is to connect a self-recovery fuse in series at the input end or add a circuit breaker to the circuit.

Output Voltage Regulation and Over-voltage Protection Circuit

The simplest device for output voltage regulation, over-voltage and over-current protection is a linear voltage regulator with overheat protection that is connected to the input or output end in series (see Figure 2).

For dual output

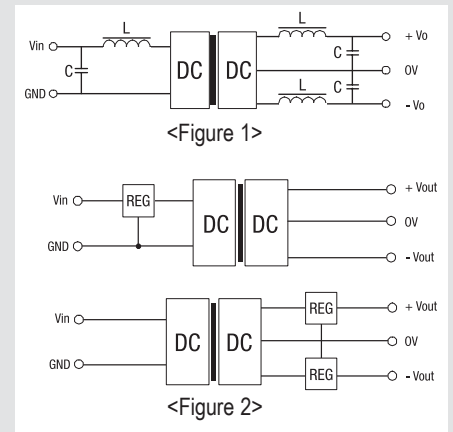

External Capacitor Table for Single Output

Vin	External Capacitor	Vout	External Capacitor
5VDC	4.7uF	5VDC	10uF
12VDC	2.2uF	9VDC	4.7uF
24VDC	1uF	12VDC	2.2uF
-	-	15VDC	1uF

External Capacitor Table for Dual Output

Vin	External Capacitor	Vout	External Capacitor
5VDC	4.7uF	5VDC	4.7uF
12VDC	2.2uF	9VDC	2.2uF
24VDC	1uF	12VDC	1uF
-	-	15VDC	0.47uF