



3.3V CMOS QUADRUPLE 2-LINE TO 1-LINE DATA SELECTOR/MULTIPLEXER, 5 VOLT TOLERANT I/O

IDT74LVC157A

FEATURES:

- 0.5 MICRON CMOS Technology
- ESD > 2000V per MIL-STD-883, Method 3015;
> 200V using machine model (C = 200pF, R = 0)
- 1.27mm pitch SOIC, 0.635mm pitch QSOP,
0.65mm pitch SSOP, 0.65mm pitch TSSOP packages
- Extended commercial range of - 40°C to +85°C
- V_{CC} = 3.3V ±0.3V, Normal Range
- V_{CC} = 2.3V to 3.6V, Extended Range
- CMOS power levels (0.4μW typ. static)
- Rail-to-Rail output swing for increased noise margin
- All inputs, outputs and I/O are 5 Volt tolerant
- Supports hot insertion

Drive Features for LVC157A:

- High Output Drivers: ±24mA
- Reduced system switching noise

DESCRIPTION:

This quadruple 2-line to 1-line data selector/multiplexer is built using advanced dual metal CMOS technology. The LVC157A features a common strobe (\bar{G}) input. When the strobe is high, all outputs are low. When the strobe is low, a 4-bit word is selected from one of two sources and is routed to the four outputs. The device provides true data.

Inputs can be driven from either 3.3V or 5V devices. This feature allows the use of this device as a translator in a mixed 3.3V/5V supply system.

The LVC157A has been designed with a ±24mA output driver. This driver is capable of driving a moderate to heavy load while maintaining speed performance.

APPLICATIONS:

- 5V and 3.3V mixed voltage systems
- Data communication and telecommunication systems

FUNCTIONAL BLOCK DIAGRAM

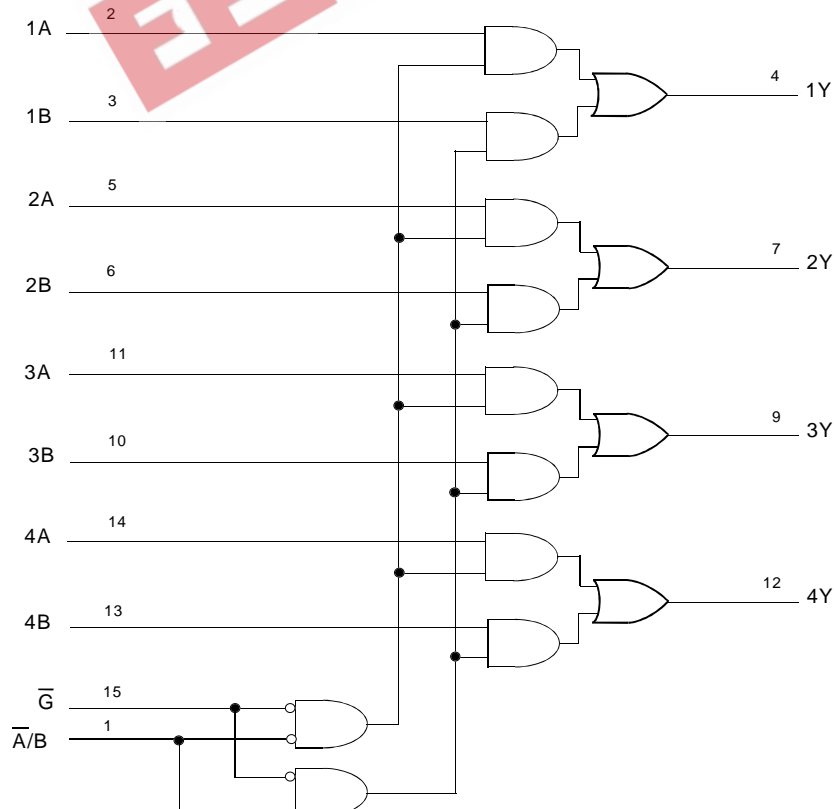

EXTENDED COMMERCIAL TEMPERATURE RANGE

FEBRUARY 2000

PIN CONFIGURATION

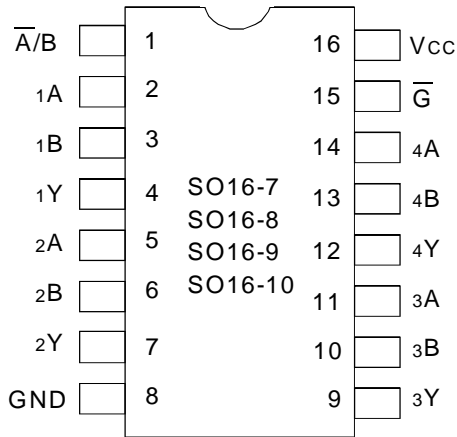

SOIC/ SSOP/ TSSOP/ QSOP
TOP VIEW

ABSOLUTE MAXIMUM RATINGS (1)

Symbol	Description	Max.	Unit
VTERM	Terminal Voltage with Respect to GND	- 0.5 to +6.5	V
TSTG	Storage Temperature	- 65 to +150	°C
IOUT	DC Output Current	- 50 to +50	mA
I _{IK}	Continuous Clamp Current, V _I < 0 or V _O < 0	- 50	mA
I _{OK}			
I _{CC}	Continuous Current through each V _{CC} or GND	±100	mA
I _{SS}			

LVC QUAD Link

NOTE:

- Stresses greater than those listed under ABSOLUTE MAXIMUM RATINGS may cause permanent damage to the device. This is a stress rating only and functional operation of the device at these or any other conditions above those indicated in the operational sections of this specification is not implied. Exposure to absolute maximum rating conditions for extended periods may affect reliability.

CAPACITANCE (T_A = +25°C, f = 1.0MHz)

Symbol	Parameter(1)	Conditions	Typ.	Max.	Unit
C _{IN}	Input Capacitance	V _{IN} = 0V	4.5	6	pF
C _{OUT}	Output Capacitance	V _{OUT} = 0V	5.5	8	pF
C _{I/O}	I/O Port Capacitance	V _{IN} = 0V	6.5	8	pF

LVC QUAD Link

NOTE:

- As applicable to the device type.

PIN DESCRIPTION

Pin Names	Description
A/B	Select Input (Active LOW)
G	Common Strobe Input (Active LOW)
xY	Data Output
xA, xB	Data Inputs

FUNCTION TABLE(1)

Inputs				Outputs
G	A/B	xA	xB	xY
H	X	X	X	L
L	L	L	X	L
L	L	H	X	H
L	H	X	L	L
L	H	X	H	H

NOTE:

- H = HIGH Voltage Level
L = LOW Voltage Level
X = Don't Care

DC ELECTRICAL CHARACTERISTICS OVER OPERATING RANGE

Following Conditions Apply Unless Otherwise Specified:

Operating Condition: $T_A = -40^{\circ}\text{C}$ to $+85^{\circ}\text{C}$

Symbol	Parameter	Test Conditions		Min.	Typ. ⁽¹⁾	Max.	Unit
V_{IH}	Input HIGH Voltage Level	$V_{CC} = 2.3\text{V}$ to 2.7V		1.7	—	—	V
		$V_{CC} = 2.7\text{V}$ to 3.6V		2	—	—	
V_{IL}	Input LOW Voltage Level	$V_{CC} = 2.3\text{V}$ to 2.7V		—	—	0.7	V
		$V_{CC} = 2.7\text{V}$ to 3.6V		—	—	0.8	
I_{IH} I_{IL}	Input Leakage Current	$V_{CC} = 3.6\text{V}$	$V_I = 0$ to 5.5V	—	—	± 5	μA
I_{OZH} I_{OZL}	High Impedance Output Current (3-State Output pins)	$V_{CC} = 3.6\text{V}$	$V_O = 0$ to 5.5V	—	—	± 10	μA
I_{OFF}	Input/Output Power Off Leakage	$V_{CC} = 0\text{V}$, V_{IN} or $V_O \leq 5.5\text{V}$		—	—	± 50	μA
V_{IK}	Clamp Diode Voltage	$V_{CC} = 2.3\text{V}$, $I_{IN} = -18\text{mA}$		—	-0.7	-1.2	V
V_H	Input Hysteresis	$V_{CC} = 3.3\text{V}$		—	100	—	mV
I_{CCL} I_{CCH} I_{CCZ}	Quiescent Power Supply Current	$V_{CC} = 3.6\text{V}$	$V_{IN} = \text{GND}$ or V_{CC}	—	—	10	μA
ΔI_{CC}	Quiescent Power Supply Current Variation	One input at $V_{CC} - 0.6\text{V}$ other inputs at V_{CC} or GND		—	—	500	μA

LVC QUAD Link

NOTE:1. Typical values are at $V_{CC} = 3.3\text{V}$, $+25^{\circ}\text{C}$ ambient.**OUTPUT DRIVE CHARACTERISTICS**

Symbol	Parameter	Test Conditions ⁽¹⁾		Min.	Max.	Unit
V_{OH}	Output HIGH Voltage	$V_{CC} = 2.3\text{V}$ to 3.6V	$I_{OH} = -0.1\text{mA}$	$V_{CC} - 0.2$	—	V
		$V_{CC} = 2.3\text{V}$	$I_{OH} = -6\text{mA}$	2	—	
		$V_{CC} = 2.3\text{V}$	$I_{OH} = -12\text{mA}$	1.7	—	
		$V_{CC} = 2.7\text{V}$		2.2	—	
		$V_{CC} = 3.0\text{V}$		2.4	—	
		$V_{CC} = 3.0\text{V}$	$I_{OH} = -24\text{mA}$	2.2	—	
V_{OL}	Output LOW Voltage	$V_{CC} = 2.3\text{V}$ to 3.6V	$I_{OL} = 0.1\text{mA}$	—	0.2	V
		$V_{CC} = 2.3\text{V}$	$I_{OL} = 6\text{mA}$	—	0.4	
			$I_{OL} = 12\text{mA}$	—	0.7	
		$V_{CC} = 2.7\text{V}$	$I_{OL} = 12\text{mA}$	—	0.4	
		$V_{CC} = 3.0\text{V}$	$I_{OL} = 24\text{mA}$	—	0.55	

LVC QUAD Link

NOTE:1. V_{IH} and V_{IL} must be within the min. or max. range shown in the DC ELECTRICAL CHARACTERISTICS OVER OPERATING RANGE table for the appropriate V_{CC} range. $T_A = -40^{\circ}\text{C}$ to $+85^{\circ}\text{C}$.

OPERATING CHARACTERISTICS, $V_{CC} = 3.3V \pm 0.3V$, $T_A = 25^\circ C$

Symbol	Parameter	Test Conditions	Typical	Unit
C_{PD}	Power Dissipation Capacitance	$C_L = 0pF$, $f = 10MHz$	16	pF

SWITCHING CHARACTERISTICS (1)

Symbol	Parameter	$V_{CC} = 2.5V \pm 0.2V$		$V_{CC} = 2.7V$		$V_{CC} = 3.3V \pm 0.3V$		Unit
		Min.	Max.	Min.	Max.	Min.	Max.	
t_{PLH} t_{PHL}	Propagation Delay xA or xB to xY	—	—	—	5.9	1	5.2	ns
t_{PLH} t_{PHL}	Propagation Delay \bar{A}/B to xY	—	—	—	8.1	1	6.8	ns
t_{PLH} t_{PHL}	Propagation Delay \bar{C} to xY	—	—	—	7.8	1	6.5	ns
$t_{SK(0)}$	Output Skew ⁽²⁾	—	—	—	—	—	1	ns

NOTES:

- See test circuits and waveforms. $T_A = -40^\circ C$ to $+85^\circ C$.
- Skew between any two outputs of the same package and switching in the same direction.

EEPW.com.cn 电子產品世界

TEST CIRCUITS AND WAVEFORMS

TEST CONDITIONS

Symbol	V _{CC} (1) = 2.5V ± 0.2V	V _{CC} (2) = 3.3V ± 0.3V & 2.7V	Unit
V _{LOAD}	2 x V _{CC}	6	V
V _{IH}	V _{CC}	2.7	V
V _T	V _{CC} / 2	1.5	V
V _{LZ}	150	300	mV
V _{HZ}	150	300	mV
C _L	30	50	pF

LVC QUAD Link

TEST CIRCUITS FOR ALL OUTPUTS

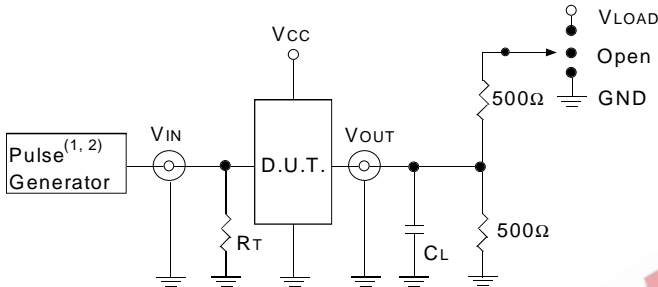

LVC QUAD Link

DEFINITIONS:

C_L = Load capacitance: includes jig and probe capacitance.
R_T = Termination resistance: should be equal to Z_{OUT} of the Pulse Generator.

NOTES:

1. Pulse Generator for All Pulses: Rate ≤ 10MHz; t_r ≤ 2ns; t_r ≤ 2ns.
2. Pulse Generator for All Pulses: Rate ≤ 10MHz; t_r ≤ 2.5ns; t_r ≤ 2.5ns.

PROPAGATION DELAY

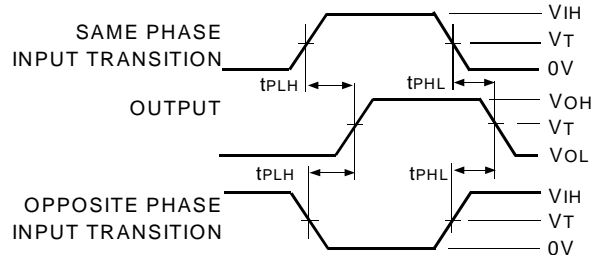

LVC QUAD Link

ENABLE AND DISABLE TIMES

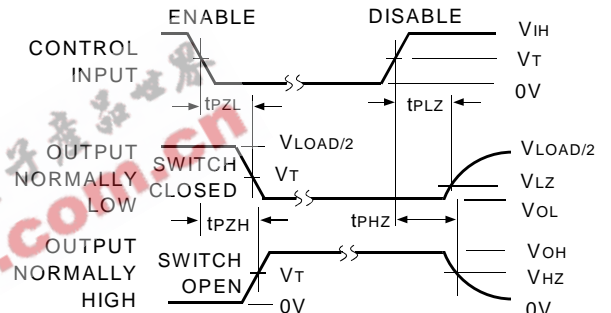

LVC QUAD Link

NOTE:

1. Diagram shown for input Control Enable-LOW and input Control Disable-HIGH.

SWITCH POSITION

Test	Switch
Open Drain Disable Low Enable Low	V _{LOAD}
Disable High Enable High	GND
All Other tests	Open

LVC QUAD Link

OUTPUT SKEW - t_{SK}(x)

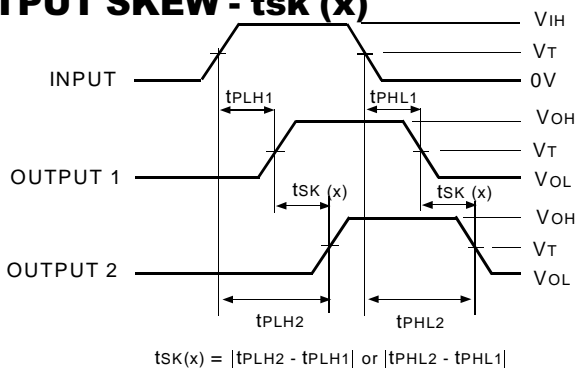

$$t_{SK}(x) = |t_{PLH2} - t_{PLH1}| \text{ or } |t_{PHL2} - t_{PHL1}|$$

LVC QUAD Link

NOTES:

1. For t_{SK}(o) OUTPUT1 and OUTPUT2 are any two outputs.
2. For t_{SK}(b) OUTPUT1 and OUTPUT2 are in the same bank.

SET-UP, HOLD, AND RELEASE TIMES

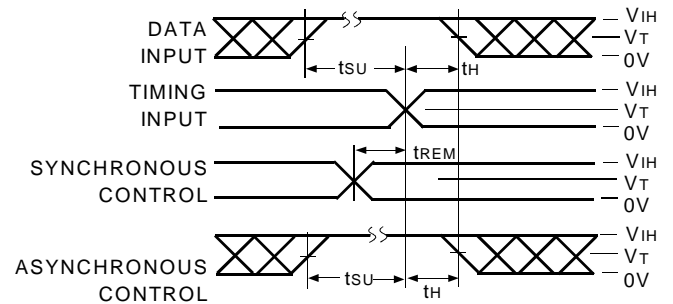

LVC QUAD Link

PULSE WIDTH

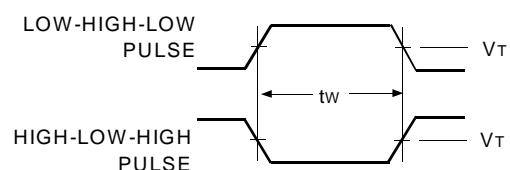

LVC QUAD Link

ORDERING INFORMATION

IDT XX LVC XXXX XX
Temp. Range Device Type Package

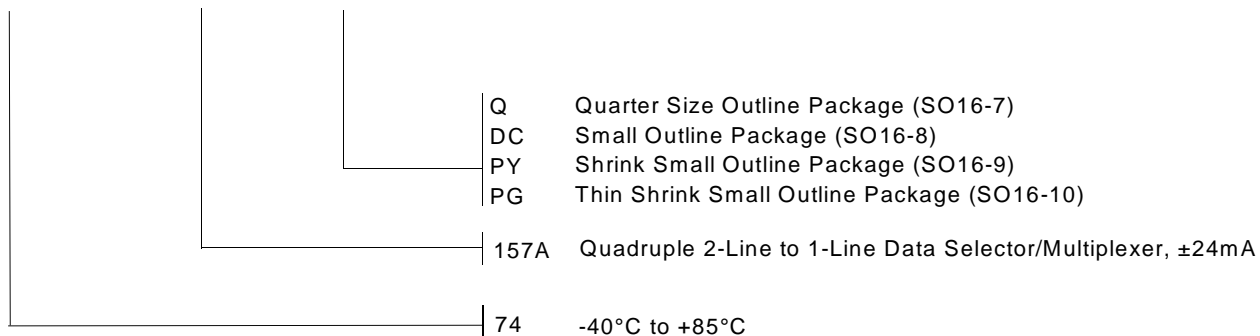

CORPORATE HEADQUARTERS
2975 Stender Way
Santa Clara, CA 95054

for SALES:
800-345-7015 or 408-727-6116
fax: 408-492-8674
www.idt.com*

*To search for sales office near you, please click the sales button found on our home page or dial the 800# above and press 2.
The IDT logo is a registered trademark of Integrated Device Technology, Inc.