

DM74ALS153 Dual 1-of-4 Line Data Selector/Multiplexer

General Description

This Data Selector/Multiplexer contains full on-chip decoding to select one-of-four data sources as a result of a unique two-bit binary code at the Select inputs. Each of the two Data Selector/Multiplexer circuits have their own separate Data and Strobe inputs and a non-inverting output buffer. The Select inputs A and B are common to both sections. The Strobe inputs, when at the HIGH level, disable their associated data inputs and force the corresponding output to the LOW state. The Select input buffers incorporate internal overlap features to ensure that select input changes do not cause invalid output transients.

Features

- Advanced oxide-isolated, ion-implanted Schottky TTL process
- Switching performance is guaranteed over full temperature and V_{CC} supply range
- Pin and functional compatible with LS family counterpart
- Improved output transient handling capability

Ordering Code:

Order Number	Package Number	Package Description
DM74ALS153M	M16A	16-Lead Small Outline Integrated Circuit (SOIC), JEDEC MS-012, 0.150 Narrow
DM74ALS153SJ	M16D	16-Lead Small Outline Package (SOP), EIAJ TYPE II, 5.3mm Wide
DM74ALS153N	N16E	16-Lead Plastic Dual-In-Line Package (PDIP), JEDEC MS-001, 0.300 Wide

Devices also available in Tape and Reel. Specify by appending the suffix letter "X" to the ordering code.

Connection Diagram

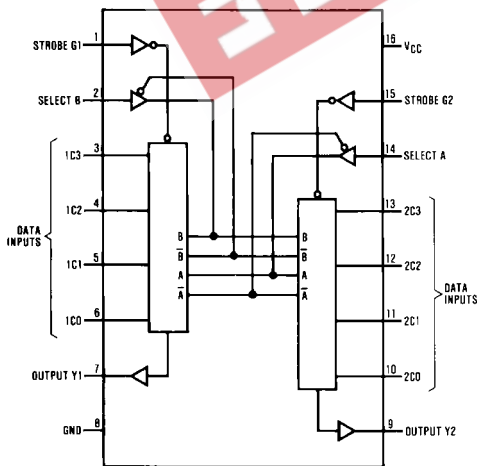

Function Table

Select Inputs		Data Inputs				Strobe	Output
B	A	C0	C1	C2	C3	G	Y
X	X	X	X	X	X	H	L
L	L	L	X	X	X	L	L
L	L	H	X	X	X	L	H
L	H	X	L	X	X	L	L
L	H	X	H	X	X	L	H
H	L	X	X	L	X	L	L
H	L	X	X	H	X	L	H
H	H	X	X	L	L	L	L
H	H	X	X	X	H	L	H

Select inputs A and B are common to both sections.
H = HIGH Level
L = LOW Level
X = Don't Care

Logic Diagram

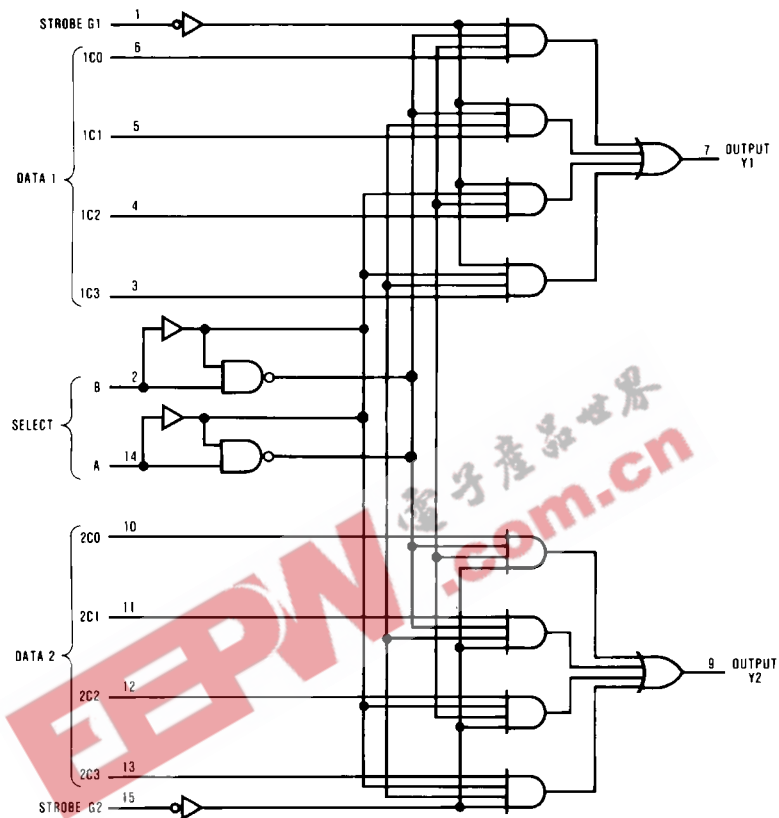

Absolute Maximum Ratings(Note 1)

Supply Voltage	7V
Input Voltage	7V
Operating Free Air Temperature Range	0°C to +70°C
Storage Temperature Range	-65°C to +150°C
Typical θ_{JA}	
N Package	78.0°C/W
M Package	107.0°C/W

Note 1: The "Absolute Maximum Ratings" are those values beyond which the safety of the device cannot be guaranteed. The device should not be operated at these limits. The parametric values defined in the Electrical Characteristics tables are not guaranteed at the absolute maximum ratings. The "Recommended Operating Conditions" table will define the conditions for actual device operation.

Recommended Operating Conditions

Symbol	Parameter	Min	Nom	Max	Units
V_{CC}	Supply Voltage	4.5	5	5.5	V
V_{IH}	HIGH Level Input Voltage	2			V
V_{IL}	LOW Level Input Voltage			0.8	V
I_{OH}	HIGH Level Output Current			-2.6	mA
I_{OL}	LOW Level Output Current			24	mA
T_A	Free Air Operating Temperature	0		70	°C

Electrical Characteristics

over recommended operating free air temperature range. All typical values are measured at $V_{CC} = 5V$, $T_A = 25^\circ C$.

Symbol	Parameter	Conditions	Min	Typ	Max	Units
V_{IK}	Input Clamp Voltage	$V_{CC} = 4.5V$, $I_{IN} = -18 mA$			-1.5	V
V_{OH}	HIGH Level Output Voltage	$V_{CC} = 4.5V$, $I_{OH} = Max$	2.4	3.2		V
	Output Voltage	$I_{OH} = -400 \mu A$, $V_{CC} = 4.5V$ to $5.5V$	$V_{CC} - 2$			V
V_{OL}	LOW Level Output Voltage	$V_{CC} = 4.5V$		0.35	0.5	V
	Output Voltage	$I_{OL} = 24 mA$				V
I_I	Input Current at Max Input Voltage	$V_{CC} = 5.5V$, $V_{IN} = 7V$			0.1	mA
I_{IH}	High Level Input Current	$V_{CC} = 5.5V$, $V_{IN} = 2.7V$			20	μA
I_{IL}	Low Level Input Current	$V_{CC} = 5.5V$, $V_{IN} = 0.4V$			-0.1	mA
I_O	Output Drive Current	$V_{CC} = 5.5V$, $V_{OUT} = 2.25V$	-30		-112	mA
I_{CC}	Supply Current	$V_{CC} = 5.5V$		7.5	14	mA
		All Inputs = 4.5V				

Switching Characteristics

over recommended operating free air temperature range.

Symbol	Parameter	Conditions	From	To	Min	Max	Units
t_{PLH}	Propagation Delay Time LOW-to-HIGH Level Output	$V_{CC} = 4.5V$ to $5.5V$ $C_L = 50 pF$ $R_L = 500\Omega$	Select	Y	5	21	ns
t_{PHL}	Propagation Delay Time HIGH-to-LOW Level Output		Select	Y	5	21	ns
t_{PLH}	Propagation Delay Time LOW-to-HIGH Level Output		Data	Y	3	10	ns
t_{PHL}	Propagation Delay Time HIGH-to-LOW Level Output		Data	Y	4	15	ns
t_{PLH}	Propagation Delay Time LOW-to-HIGH Level Output		Strobe	Y	5	18	ns
t_{PHL}	Propagation Delay Time HIGH-to-LOW Level Output		Strobe	Y	5	18	ns
t_{PHL}	Propagation Delay Time HIGH-to-LOW Level Output						

Physical Dimensions inches (millimeters) unless otherwise noted

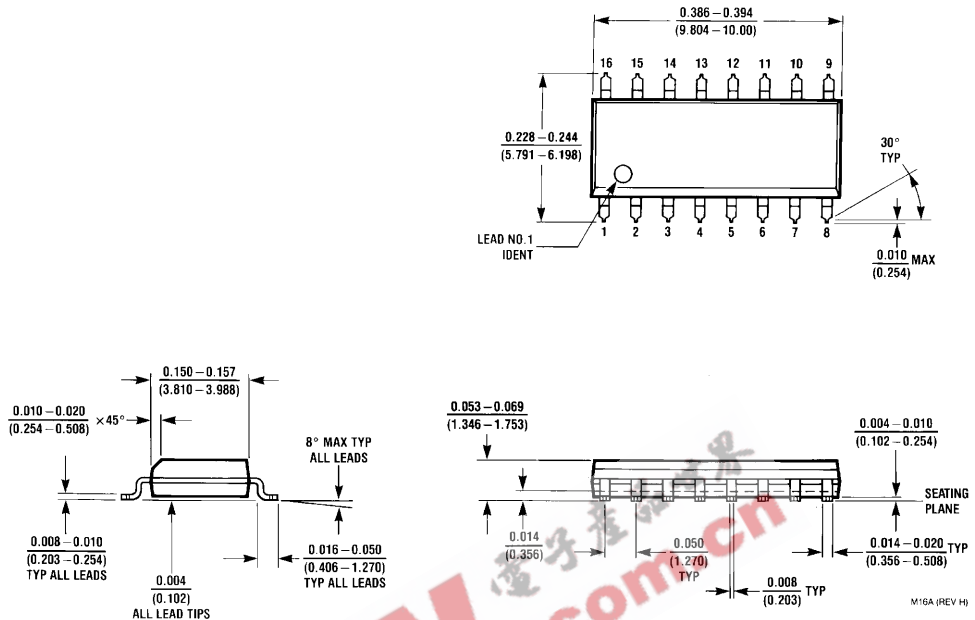

16-Lead Small Outline Integrated Circuit (SOIC), JEDEC MS-012, 0.150 Narrow Package Number M16A

Physical Dimensions inches (millimeters) unless otherwise noted (Continued)

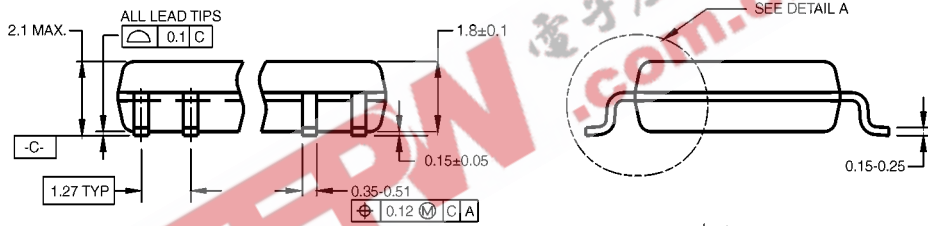
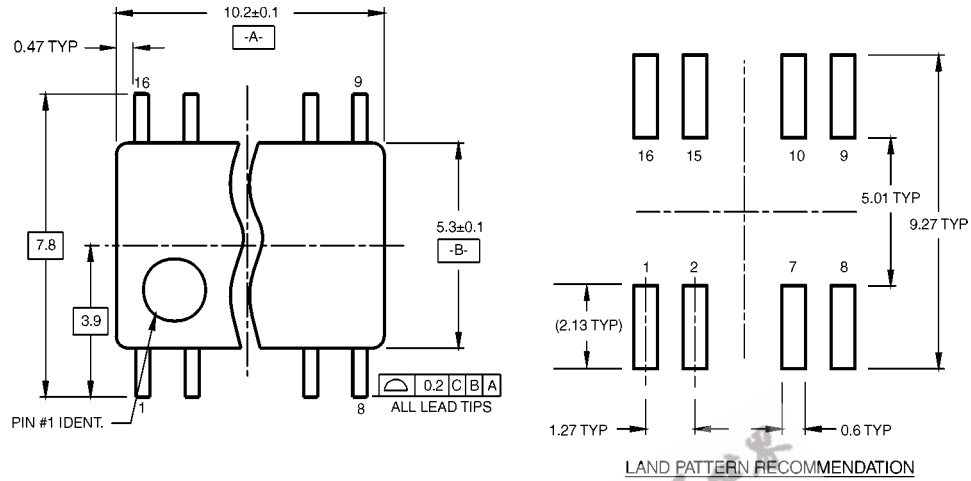

DIMENSIONS ARE IN MILLIMETERS

- NOTES:
- A. CONFORMS TO EIAJ EDR-7320 REGISTRATION, ESTABLISHED IN DECEMBER, 1998.
 - B. DIMENSIONS ARE IN MILLIMETERS.
 - C. DIMENSIONS ARE EXCLUSIVE OF BURRS, MOLD FLASH, AND TIE BAR EXTRUSIONS.

M16DRevB1

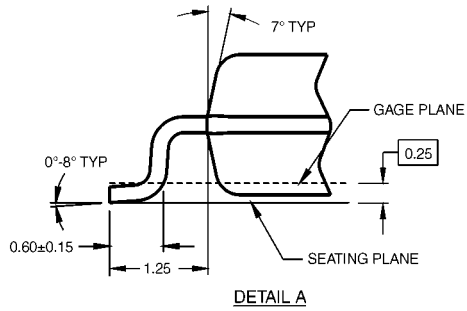

16-Lead Small Outline Package (SOP), EIAJ TYPE II, 5.3mm Wide Package Number M16D

Physical Dimensions inches (millimeters) unless otherwise noted (Continued)

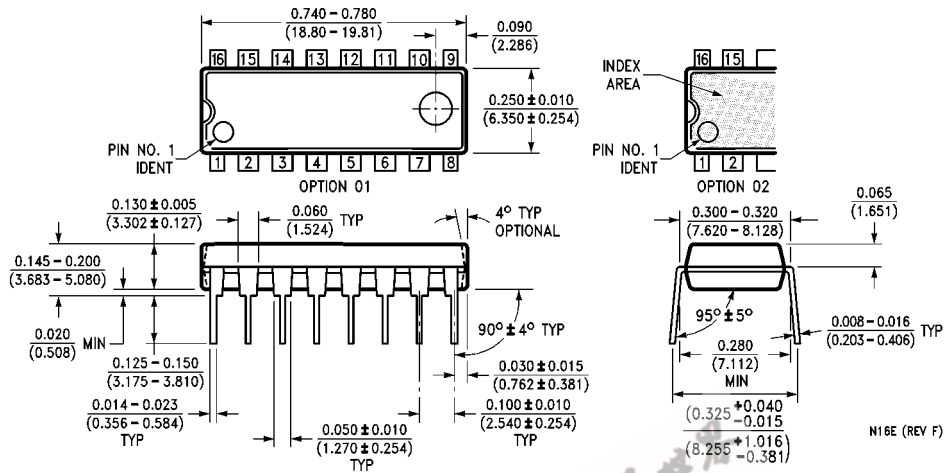

16-Lead Plastic Dual-In-Line Package (PDIP), JEDEC MS-001, 0.300 Wide
Package Number N16E

Fairchild does not assume any responsibility for use of any circuitry described, no circuit patent licenses are implied and Fairchild reserves the right at any time without notice to change said circuitry and specifications.

LIFE SUPPORT POLICY

FAIRCHILD'S PRODUCTS ARE NOT AUTHORIZED FOR USE AS CRITICAL COMPONENTS IN LIFE SUPPORT DEVICES OR SYSTEMS WITHOUT THE EXPRESS WRITTEN APPROVAL OF THE PRESIDENT OF FAIRCHILD SEMICONDUCTOR CORPORATION. As used herein:

1. Life support devices or systems are devices or systems which, (a) are intended for surgical implant into the body, or (b) support or sustain life, and (c) whose failure to perform when properly used in accordance with instructions for use provided in the labeling, can be reasonably expected to result in a significant injury to the user.
2. A critical component in any component of a life support device or system whose failure to perform can be reasonably expected to cause the failure of the life support device or system, or to affect its safety or effectiveness.

www.fairchildsemi.com