

Features

- UL Recognized Component
- Ideal for Printed Circuit Board
- Glass Passivated Chip Junctions, Surge Overload Rating of 50A Peak
- Simple, Compact Structure for Trouble-free Performance
- Plastic Package - UL Flammability Classification 94V-0

Mechanical Data

- Terminals: Tin Plated Leads Solderable per MIL-STD-202, Method 208
- Case: Transfer Molded Epoxy
- Mounting Position: Any
- Polarity: Polarity Symbols Marked on Body
- Approx. Weight: 1.0 grams

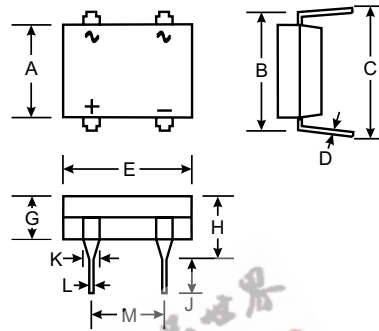

DB-1		
Dim	Min	Max
A	6.10	6.60
B	7.11	8.13
C	8.13	9.40
D	0.20	0.38
E	-	9.40
G	-	3.30
H	-	5.51
J	2.80	3.68
K	1.02	1.40
L	0.51 Typical	
M	5.15 Typical	
All Dimensions in mm		

Maximum Ratings and Electrical Characteristics @ T_A = 25°C unless otherwise specified

Characteristic	Symbol	DB 101	DB 102	DB 103	DB 104	DB 105	DB 106	DB 107	Unit
Maximum Recurrent Peak Reverse Voltage	V _{RRM}	50	100	200	400	600	800	1000	V
Maximum RMS Input Voltage	V _{RMS}	35	70	140	280	420	560	700	V
Maximum DC Blocking Voltage	V _{DC}	50	100	200	400	600	800	1000	V
Maximum Average Rectified Output Current @ T _A = 40°C	I _(AV)	1.0							A
Peak Forward Surge Current Single Half Sine-wave Superimposed on Rated Load (JEDEC Method)	I _{FSM}	50							A
Maximum Instantaneous Forward Voltage drop per Element at I _F = 1.0A	V _F	1.1							V
Maximum Reverse DC Current at Rated DC Blocking Voltage per Element	I _R	10 1.0							μA mA
Typical Thermal Resistance (Note 1)	R _{gJA}	40							K/W
Storage and Operating Temperature Range	T _J , T _{STG}	-55 to +150							°C

- Notes:
1. Thermal resistance from junction to ambient mounted on PC board with 13mm x 13mm copper pads.
 2. 60 Hz resistive or inductive load.
 3. For capacitive load, derate current by 20%.

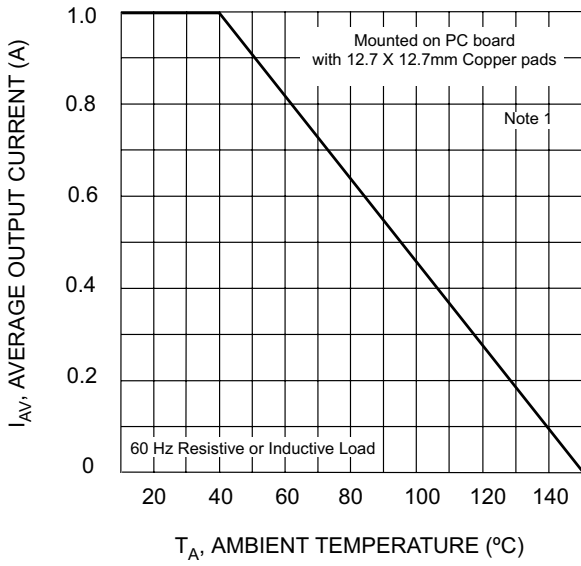

Fig. 1 Maximum Output Rectified Current

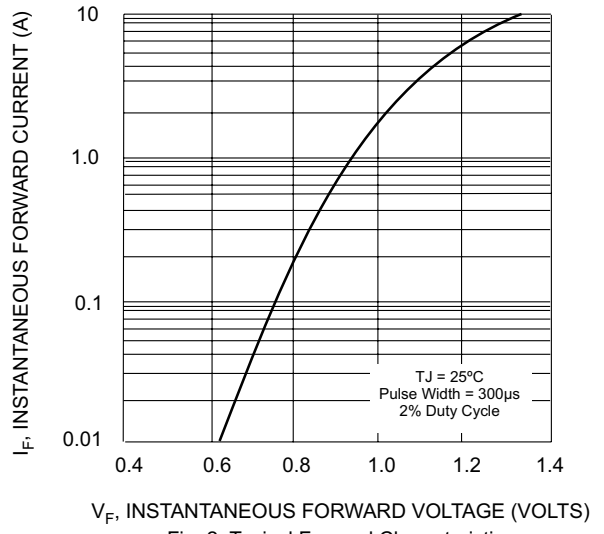

Fig. 2 Typical Forward Characteristics

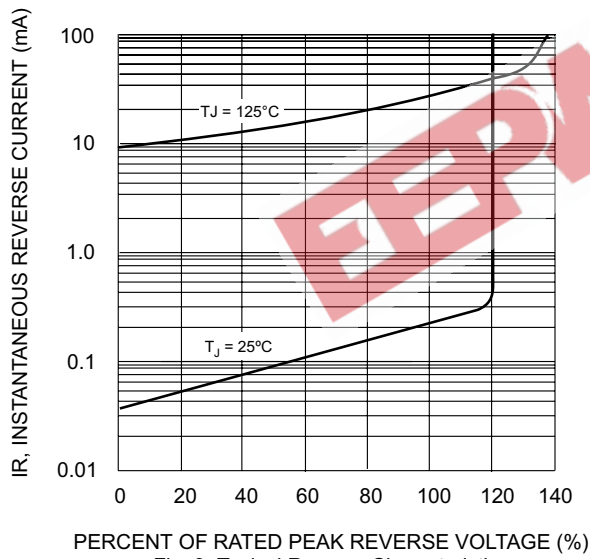

Fig. 3 Typical Reverse Characteristics

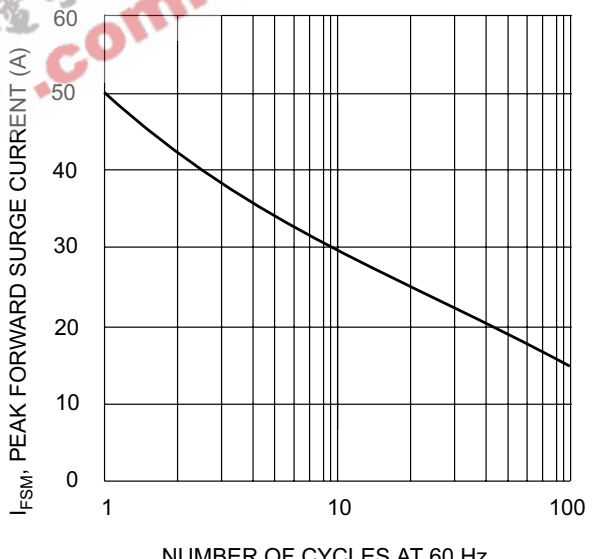

Fig. 4 Max Non-Repetitive Peak Forward Surge Current