



 SUMITOMO ELECTRIC

01.08.28

◆ **Features**

- Up to 1.5 Gbps high speed operation
- -5 V single power supply
- Up to 40 mA p-p modulation current
- Up to 50 mA bias current
- Maximum bias current preset control

◆ **Applications**

- Laser diode driver of an optical transmitter circuit for SDH (STM4)

◆ **Functional Description**

The F0510203B is a high performance GaAs integrated laser diode driver for use in an optical transmitter circuit up to 1.5 Gbps NRZ data rate. The F0510203B typically specifies rise time and fall time of 100 psec (20% - 80%). It features single -5 V supply operation, 1 to 50 mA presettable bias current and up to 40 mA modulation current.

F0510203B

1.5Gbps Laser Diode Driver

With Input Bias Circuit



◆ **Absolute Maximum Ratings** $T_a = 25\text{ }^\circ\text{C}$, unless specified

Parameter	Symbol	Value	Units
Supply Voltage	V_{SS}	$V_{DD} - 7$ to $V_{DD} + 0.5$	V
Input Voltage	V_{IN1}, V_{IN2}	V_{SS} to $V_{DD} + 0.5$	V
Output Voltage	V_{OUT1}, V_{OUT2}	V_{SS} to $V_{DD} + 0.5$	V
Modulation Current Control Voltage	V_M	V_{SS} to $V_{SS} + 1.3$	V
Maximum Bias Current Setting Voltage	V_B	V_{SS} to $V_{SS} + 1.7$	V
Storage Temperature	Tstg	-55 to +125	$^\circ\text{C}$
Ambient Operating Temperature	T_a	-40 to +85	$^\circ\text{C}$

◆ **Recommended Operating Conditions** $V_{DD} = \text{GND}$

Parameter	Symbol	Value			Units
		Min.	Typ.	Max.	
Supply Voltage	V_{SS}	$V_{DD} - 5.25$	$V_{DD} - 5$	$V_{DD} - 4.75$	V
Ambient Operating Temperature	T_a	0	25	85	$^\circ\text{C}$

◆ **Electrical Characteristics**

$T_a = 0 \sim 85^\circ\text{C}$, $V_{SS} = -5.25 \sim -4.75\text{V}$, $V_{DD} = \text{GND}$ unless specified

Parameter	Symbol	TestConditions	Value			Units
			Min.	Typ.	Max.	
Circuit Current (1)	I_{SS}	$V_M = V_B = V_{SS}$, without I_M, I_B	-	28	40	mA
Input Voltage	V_{IH}	Differential Mode	-1.0	-	-0.8	V
	V_{IL}		-1.8	-	-1.6	V
Input Current	I_{IN1}, I_{IN2}	$V_{IN1}, V_{IN2} = -1.8\text{V}$	-80	-	80	μA
Modulation Current	I_{MMAX}	$V_M = V_{SS} + 1.3\text{V}$, $T_a = 25^\circ\text{C}$	40	-	-	mA
Bias Current	I_{BMAX}	$V_B = V_{SS} + 1.7\text{V}$, $T_a = 25^\circ\text{C}$	50	-	-	mA
Bias Current Setting Voltage (IM=20mA)	V_{M20}	$I_M = 20\text{mA}$, $V_{SS} = -5\text{V}$ $T_a = 25^\circ\text{C}$	$V_{SS} + 0.73$	-	$V_{SS} + 0.92$	V
LEAK Current	I_{LEAK}	$V_M = V_{SS} + 0.01\text{V}$ $V_B = V_{SS} + 0.1\text{V}$	-	-	0.9	mA
Rise Time	tr	RL = 25 Ω 20% - 80%	-	100	150	ps
Fall Time	tf	RL = 25 Ω 20% - 80%	-	100	150	ps

◆ **Block Diagram**

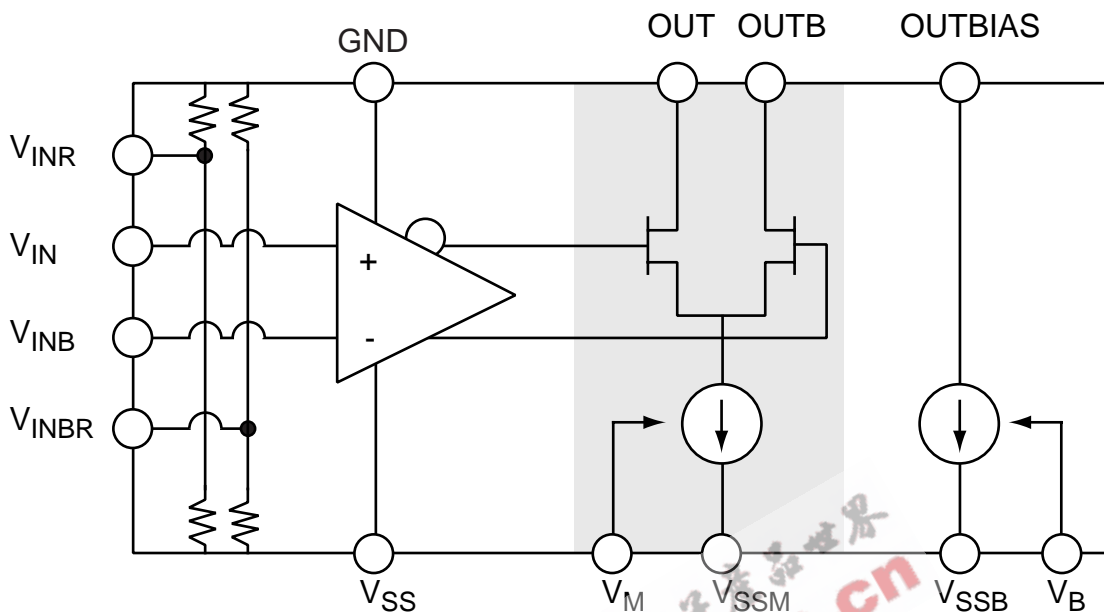

◆ **Die Pad Description**

V_{IN}	Input
V_{INR}	Bias Voltage for Input
V_{INB}	Input
V_{INBR}	Bias Voltage for Input
V_{SS}	Supply Voltage
V_{SSM}	Supply Voltage
V_{SSB}	Supply Voltage
V_M	Modulation Current control
V_B	Bias Current Control
OUT	Output
OUTB	Output
OUTBIAS	Bias Current for Laser
GND	GND

◆ Die Pad Assignments

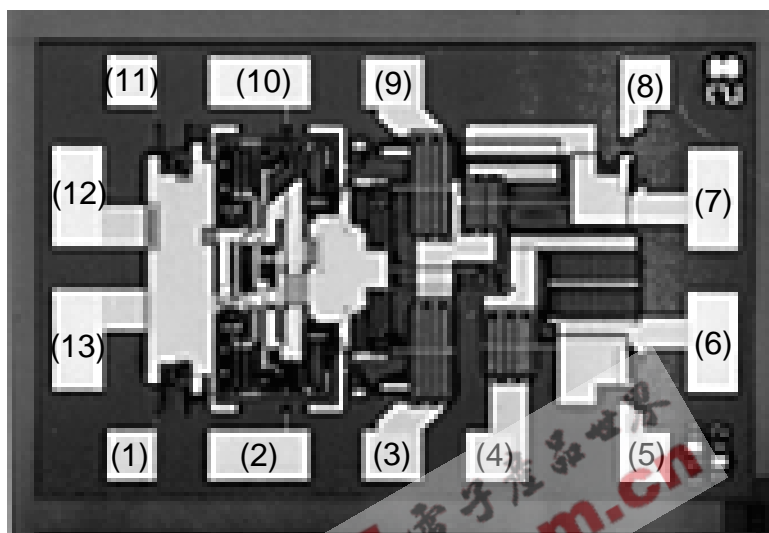

No.	Symbol	Center Coordinates(μm)	No.	Symbol	Center Coordinates(μm)
(1)	V_{IN}	(184,80)	(10)	V_{INBR}	(470,810)
(2)	V_{INR}	(470,80)	(11)	V_{INB}	(184,810)
(3)	OUT	(680,80)	(12)	V_{DD}	(80,585)
(4)	OUTBIAS	(880,80)	(13)	V_{SS}	(80,305)
(5)	V_B	(1180,80)	O		(0,0)
(6)	V_{SSB}	(1310,305)	A		(1390,890)
(7)	V_{SSM}	(1310,585)			
(8)	V_M	(1180,810)			
(9)	OUTB	(680,810)			

◆ Test Circuits

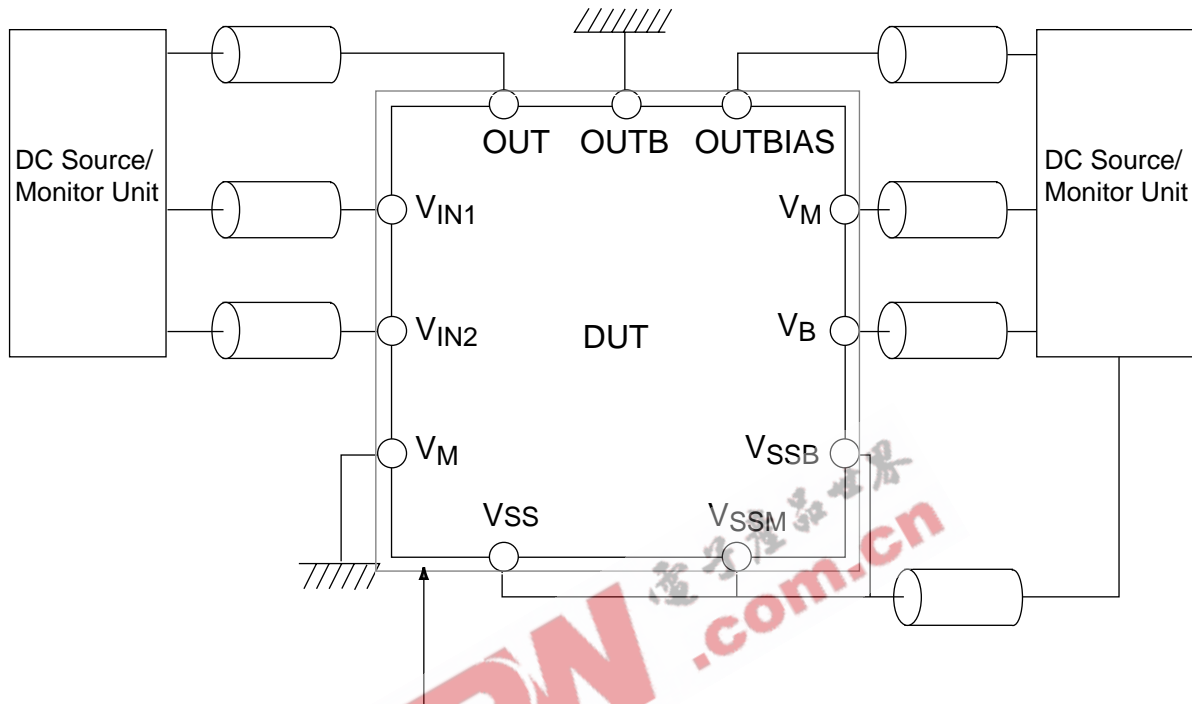

Probing System with Temp. chuck

◆ Typical DC Characteristics

(1) Switching Characteristics

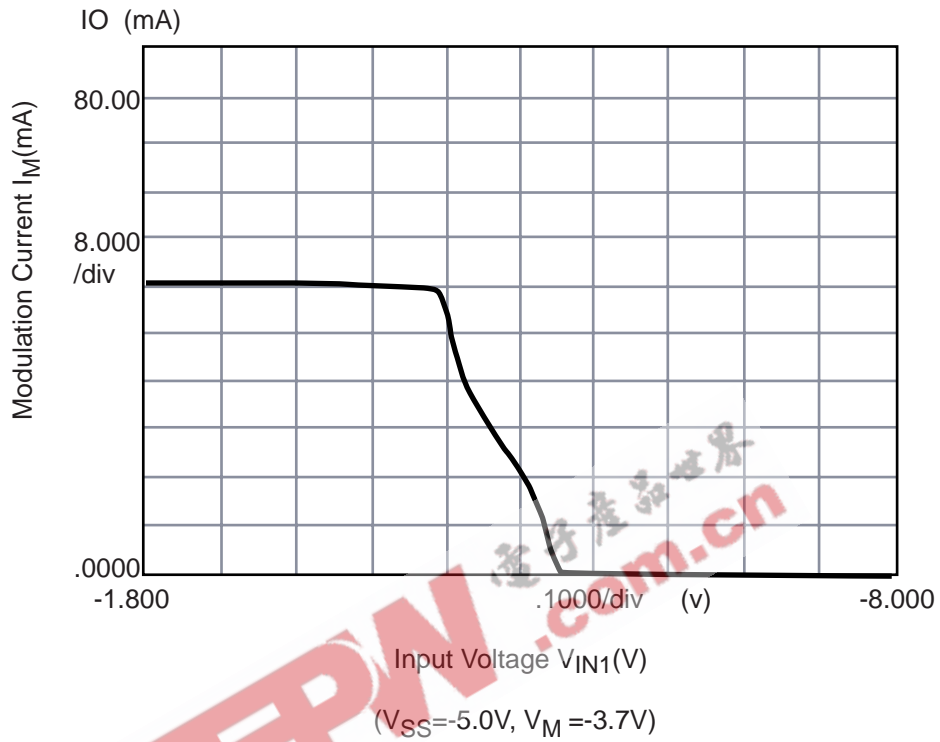

(2) Modulation Current Control

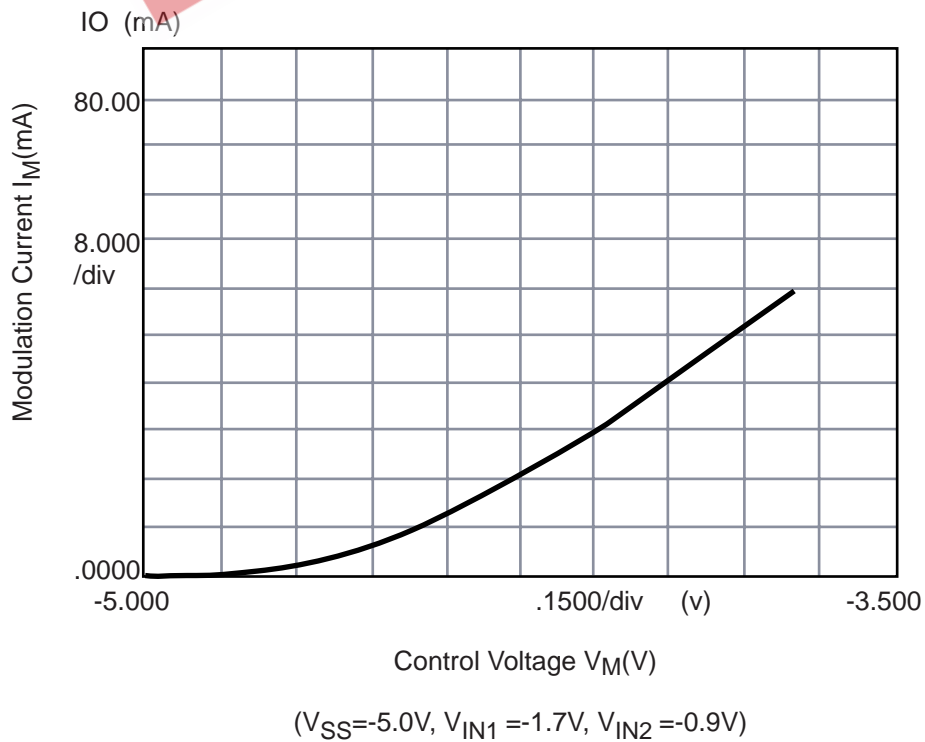

(3) Bias Current Control

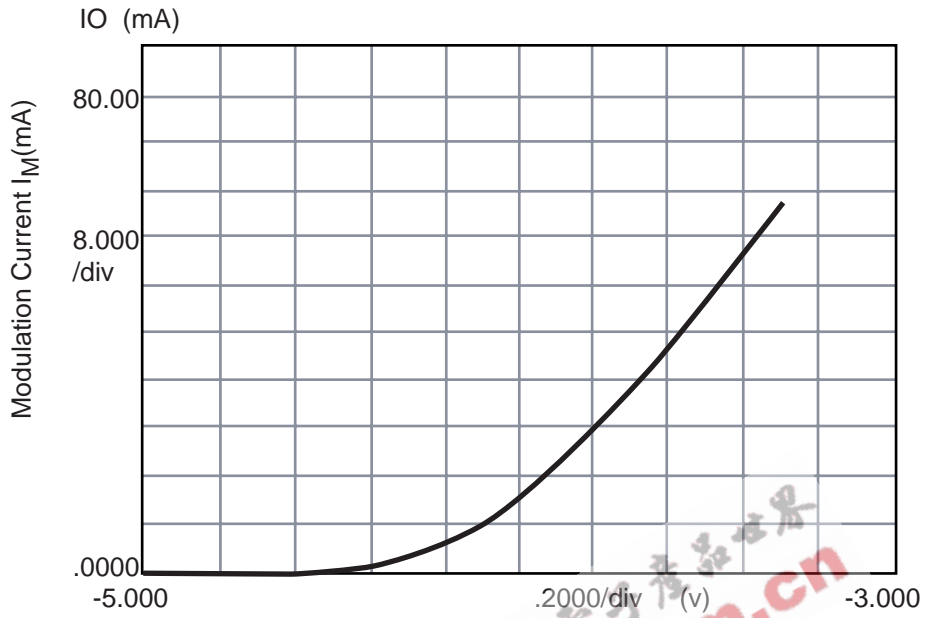

($V_{SS}=-5.0V, V_{IN1}, V_{IN2}, V_M$: no connect)

