



KBP151G - KBP157G

Single Phase 1.5 AMPS.
Glass Passivated Bridge Rectifiers

KBP

Features

- ✧ UL Recognized File # E-96005
- ✧ Glass passivated junction
- ✧ Ideal for printed circuit board
- ✧ Reliable low cost construction
- ✧ High surge current capability
- ✧ High temperature soldering guaranteed:
260 °C / 10 seconds at 5 lbs., (2.3 kg)
tension
- ✧ Small size, simple installation
- ✧ Leads solderable per MIL-STD-202,
Method 208

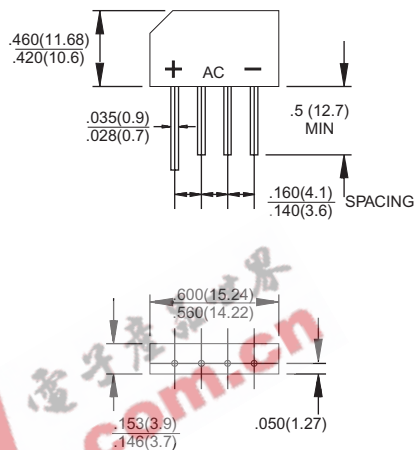

Dimensions in inches and (millimeters)

Maximum Ratings and Electrical Characteristics

Rating at 25 °C ambient temperature unless otherwise specified.

Single phase, half wave, 60 Hz, resistive or inductive load.

For capacitive load, derate current by 20%

Type Number	Symbol	KBP 151G	KBP 152G	KBP 153G	KBP 154G	KBP 155G	KBP 156G	KBP 157G	Units
Maximum Recurrent Peak Reverse Voltage	V_{RRM}	50	100	200	400	600	800	1000	V
Maximum RMS Voltage	V_{RMS}	35	70	140	280	420	560	700	V
Maximum DC Blocking Voltage	V_{DC}	50	100	200	400	600	800	1000	V
Maximum Average Forward Rectified Current @ $T_A = 50\text{ }^\circ\text{C}$	$I_{(AV)}$	1.5							A
Peak Forward Surge Current, 8.3 ms Single Half Sine-wave Superimposed on Rated Load (JEDEC method)	I_{FSM}	50							A
Maximum Instantaneous Forward Voltage @ 1.5A	V_F	1.1							V
Maximum DC Reverse Current @ $T_A=25\text{ }^\circ\text{C}$ at Rated DC Blocking Voltage @ $T_A=125\text{ }^\circ\text{C}$	I_R	10 500							μA μA
Typical Thermal Resistance (Note)	$R_{\theta JA}$ $R_{\theta JL}$	40 13							$^\circ\text{C/W}$
Operating Temperature Range	T_J	-55 to +150							$^\circ\text{C}$
Storage Temperature Range	T_{STG}	-55 to +150							$^\circ\text{C}$

Note: Thermal Resistance from Junction to Ambient and from Junction to Lead Mounted on P.C.B.
with 0.4" x 0.4" (10mm x 10mm) Copper Pads.

RATINGS AND CHARACTERISTIC CURVES (KBP151G THRU KBP157G)

FIG.1- MAXIMUM FORWARD CURRENT DERATING CURVE

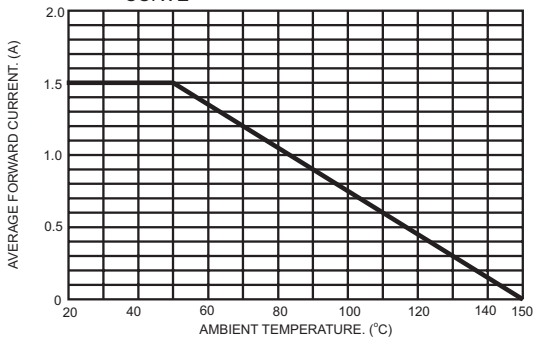

FIG.2- TYPICAL REVERSE CHARACTERISTICS

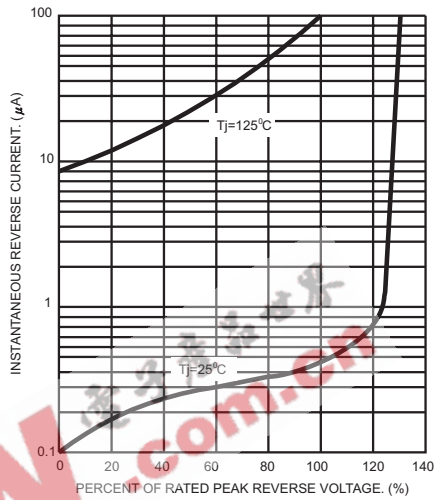

FIG.3- MAXIMUM NON-REPETITIVE FORWARD SURGE CURRENT PER BRIDGE ELEMENT

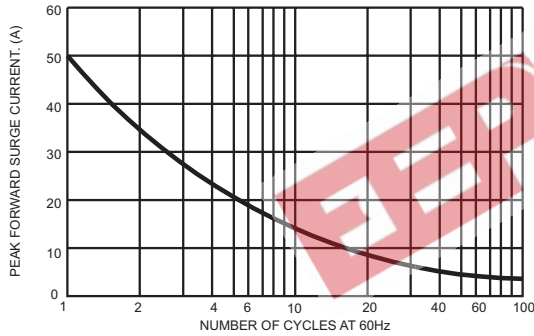

FIG.4- TYPICAL JUNCTION CAPACITANCE

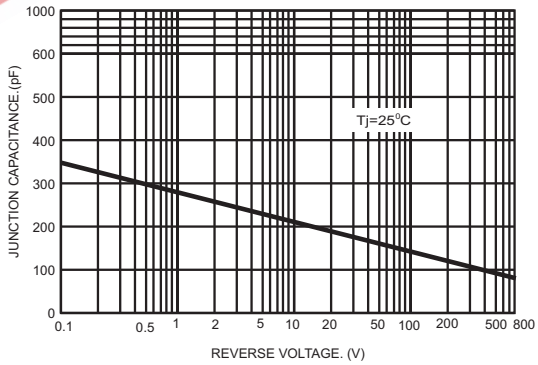

FIG.5- TYPICAL FORWARD CHARACTERISTICS PER BRIDGE ELEMENT

