



1GB-128Mx72,SDRAM UNBUFFERED

*ADVANCED

FEATURES

- Burst Mode Operation
- Auto and Self Refresh capability
- LVTTTL compatible inputs and outputs
- Serial Presence Detect with EEPROM
- Fully synchronous: All signals are registered on the positive edge of the system clock
- Programmable Burst Lengths: 1, 2, 4, 8 or Full Page
- 3.3 volt ± 0.3v Power Supply
- 168- Pin DIMM JEDEC

DESCRIPTION

The WED3DG72126V is organized as a 128Mx72 synchronous DRAM module which consists of eighteen 64Mx8 stack SDRAM components in TSOP- 11 package, and one 2K EEPROM in an 8-pin TSSOP package for Serial Presence Detect which are mounted on a 168 Pin DIMM multilayer FR4 Substrate.

* This datasheet describes a product that may or may not be under development and is subject to change or cancellation without notice.

PIN CONFIGURATIONS (FRONT SIDE/BACK SIDE)

Pin	Front	Pin	Front	Pin	Front	Pin	Back	Pin	Back	Pin	Back
1	VSS	29	DQM1	57	DQ18	85	VSS	113	DQM5	141	DQ50
2	DQ0	30	CS0	58	DQ19	86	DQ32	114	CS1	142	DQ51
3	DQ1	31	DNU	59	VDD	87	DQ33	115	RAS	143	VDD
4	DQ2	32	VSS	60	DQ20	88	DQ34	116	VSS	144	DQ52
5	DQ3	33	A0	61	NC	89	DQ35	117	A1	145	NC
6	VDD	34	A2	62	*VREF	90	VDD	118	A3	146	*VREF
7	DQ4	35	A4	63	CKE1	91	DQ36	119	A5	147	NC
8	DQ5	36	A6	64	VSS	92	DQ37	120	A7	148	VSS
9	DQ6	37	A8	65	DQ21	93	DQ38	121	A9	149	DQ53
10	DQ7	38	A10/AP	66	DQ22	94	DQ39	122	BA0	150	DQ54
11	DQ8	39	BA1	67	DQ23	95	DQ40	123	A11	151	DQ55
12	VSS	40	VDD	68	VSS	96	VSS	124	VDD	152	VSS
13	DQ9	41	VDD	69	DQ24	97	DQ41	125	CLK1	153	DQ56
14	DQ10	42	CLK0	70	DQ25	98	DQ42	126	A12	154	DQ57
15	DQ11	43	VSS	71	DQ26	99	DQ43	127	VSS	155	DQ58
16	DQ12	44	DNU	72	DQ27	100	DQ44	128	CKE0	156	DQ59
17	DQ13	45	CS2	73	VDD	101	DQ45	129	CS3	157	VDD
18	VDD	46	DQM2	74	DQ28	102	VDD	130	DQM6	158	DQ60
19	DQ14	47	DQM3	75	DQ29	103	DQ46	131	DQM7	159	DQ61
20	DQ15	48	DNU	76	DQ30	104	DQ47	132	*A13	160	DQ62
21	CB0	49	VDD	77	DQ31	105	CB4	133	VDD	161	DQ63
22	CB1	50	NC	78	VSS	106	CB5	134	NC	162	VSS
23	VSS	51	NC	79	CLK2	107	VSS	135	NC	163	CLK3
24	NC	52	CB2	80	NC	108	NC	136	CB6	164	NC
25	NC	53	CB3	81	NC	109	NC	137	CB7	165	**SA0
26	VDD	54	VSS	82	**SDA	110	VDD	138	VSS	166	**SA1
27	WE	55	DQ16	83	**SCL	111	CAS	139	DQ48	167	**SA2
28	DQM0	56	DQ17	84	VDD	112	DQM4	140	DQ49	168	VDD

PIN NAMES

A0 – A12	Address input (Multiplexed)
BA0-1	Select Bank
DQ0-63	Data Input/Output
CB0-7	Check bit (Data-in/data-out)
CLK0-CLK3	Clock input
CKE0,CKE1	Clock Enable input
CS0-CS3	Chip select Input
RAS	Row Address Strobe
CAS	Column Address Strobe
WE	Write Enable
DQM0-7	DQM
VDD	Power Supply (3.3V)
VSS	Ground
*VREF	Power supply for reference
SDA	Serial data I/O
SCL	Serial clock
SA0-2	Address in EEPROM
DNU	Do not use
NC	No Connect

* These pins are not used in this module.

** These pins should be NC in the system which does not support SPD.



FUNCTIONAL BLOCK DIAGRAM

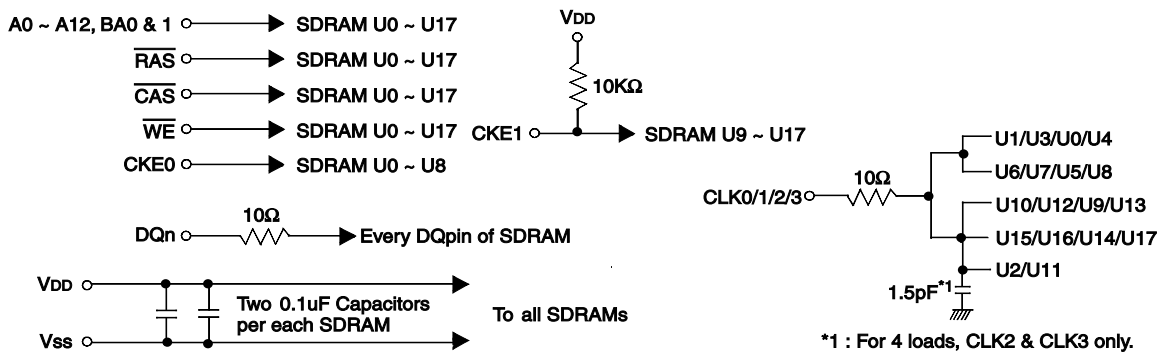
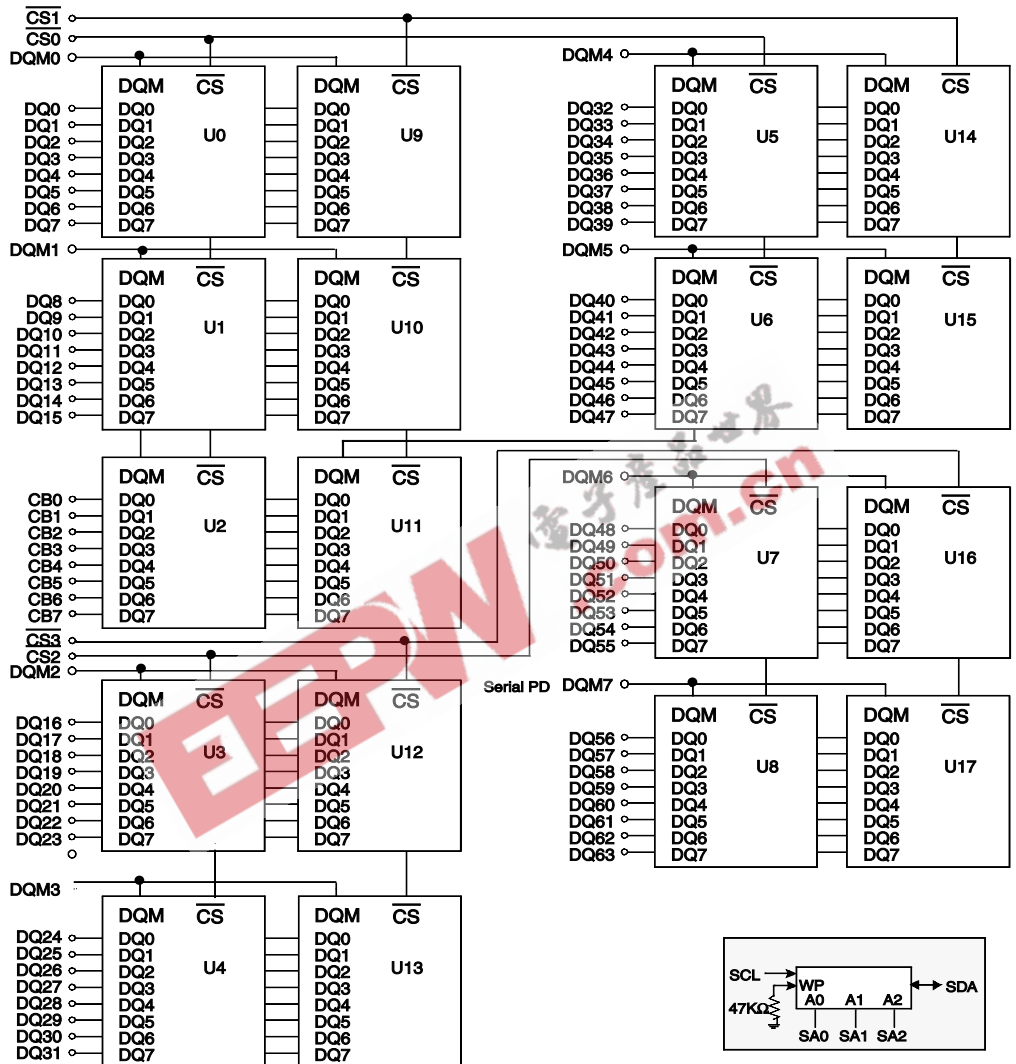



ABSOLUTE MAXIMUM RATINGS

Parameter	Symbol	Value	Units
Voltage on any pin relative to VSS	V _{IN} , V _{out}	-1.0 ~ 4.6	V
Voltage on VDD supply relative to VSS	VDD, VDDQ	-1.0 ~ 4.6	V
Storage Temperature	TSTG	-55 ~ +150	°C
Power Dissipation	PD	18	W
Short Circuit Current	IOS	50	mA

Note: Permanent device damage may occur if "ABSOLUTE MAXIMUM RATINGS" are exceeded.
 Functional operation should be restricted to recommended operating condition.
 Exposure to higher than recommended voltage for extended periods of time could affect device reliability.

RECOMMENDED DC OPERATING CONDITIONS

(Voltage Referenced to: V_{SS} = 0V, T_A = 0°C to +70°C)

Parameter	Symbol	Min	Typ	Max	Unit	Note
Supply Voltage	VDD	3.0	3.3	3.6	V	
Input High Voltage	V _{IH}	2.0	3.0	VDDQ+0.3	V	1
Input Low Voltage	V _{IL}	-0.3	—	0.8	V	2
Output High Voltage	V _{OH}	2.4	—	—	V	I _{OH} = -2mA
Output Low Voltage	V _{OL}	—	—	0.4	V	I _{OL} = -2mA
Input Leakage Current	I _{LI}	-10	—	10	µA	3

Note: 1. V_{IH} (max)= 5.6V AC. The overshoot voltage duration is ≤ 3ns.
 2. V_{IL} (min)= -2.0V AC. The undershoot voltage duration is ≤ 3ns.
 3. Any input 0V ≤ V_{IN} ≤ VDDQ
 Input leakage currents include Hi-Z output leakage for all bi-directional buffers with Tri-State outputs.

CAPACITANCE

(T_A = 23°C, f = 1MHz, VDD = 3.3V, VREF=1.4V ± 200mV)

Parameter	Symbol	Min	Max	Unit
Input Capacitance (A0-A12)	CIN1	-	105	pF
Input Capacitance (\overline{RAS} , \overline{CAS} , \overline{WE})	CIN2	-	105	pF
Input Capacitance (CKE0)	CIN3	-	65	pF
Input Capacitance (CLK0)	CIN4	-	45	pF
Input Capacitance ($\overline{CS0}$, $\overline{CS2}$)	CIN5	-	40	pF
Input Capacitance (DQM0-DQM7)	CIN6	-	30	pF
Input Capacitance (BA0-BA1)	CIN7	-	105	pF
Data input/output capacitance (DQ0-DQ63)	Cout	-	15	pF
Data input/output capacitance (CB0-CB7)	Cout1	-	15	pF



OPERATING CURRENT CHARACTERISTICS

(VCC = 3.3V, TA = 0°C to +70°C)

Parameter	Symbol	Conditions	Version		Units	Note
			133	100		
Operating Current (One bank active)	ICC1	Burst Length = 1 tRC ≥ tRC(min) IOL = 0mA	2,250	2,070	mA	1
Precharge Standby Current in Power Down Mode	ICC2P	CKE ≤ VIL(max), tCC = 10ns	110		mA	
	ICC2PS	CKE & CLK ≤ VIL(max), tCC = ∞	90			
Precharge Standby Current in Non-Power Down Mode	icc2N	CKE ≥ VIH(min), CS ≥ VIH(min), tcc = 10ns Input signals are charged one time during 20	540		mA	
	icc2NS	CKE ≥ VIH(min), CLK ≤ VIL(max), tcc = ∞ Input signals are stable	180			
Active standby current in power-down mode	ICC3P	CKE ≥ VIL(max), tCC = 10ns	180		mA	
	ICC3PS	CKE & CLK ≤ VIL(max), tcc = ∞	145			
Active standby current in non power-down mode	ICC3N	CKE ≥ VIH(min), CS ≥ VIH(min), tcc = 10ns Input signals are changed one time during 20ns	900		mA	
	ICC3NS	CKE ≥ VIH(min), CLK ≤ VIL(max), tcc = ∞ input signals are stable	630			
Operating current (Burst mode)	ICC4	Io = mA Page burst 4 Banks activated tCCD = 2CLK	2,250	1,980	mA	1
Refresh current	ICC5	tRC ≥ tRC(min)	3,420	3,240	mA	2
Self refresh current	ICC6	CKE ≤ 0.2V	125		mA	

- Notes: 1. Measured with outputs open.
 2. Refresh period is 64ms.
 3. Unless otherwise noticed, input swing level is CMOS (VIH/VIL = VDDQ/VssQ)



ORDERING INFORMATION

Part Number	Speed	CAS Latency
WED3DG72126V10D2	100MHz	CL=2
WED3DG72126V7D2	133MHz	CL=2
WED3DG72126V75D2	133MHz	CL=3

PACKAGE DIMENSIONS

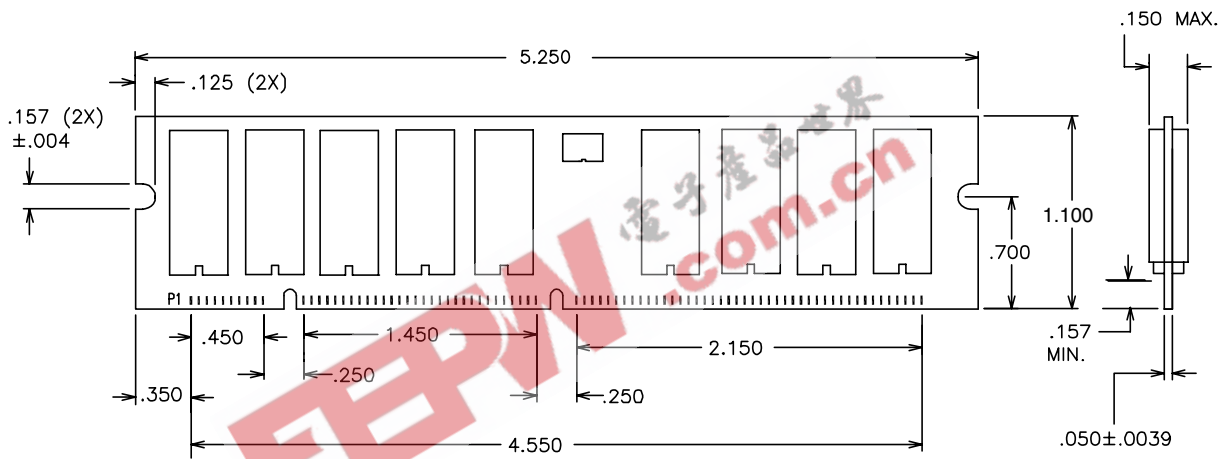

ALL DIMENSIONS ARE IN INCHES