

## Description

The TS5A3153 is a single-pole double-throw (SPDT) analog switch that is designed to operate from 1.65 V to 5.5 V. The device offers a low ON-state resistance and an excellent on-resistance matching with the break-before-make feature, to prevent signal distortion during the transferring of a signal from one channel to another. The device has an excellent total harmonic distortion (THD) performance and consumes very low power. These features make this device suitable for portable audio applications.

## Applications

- Cell Phones
- PDAs
- Portable Instrumentation
- Audio and Video Signal Routing
- Low-Voltage Data Acquisition System
- Communication Circuits
- Modems
- Hard Drives
- Computer Peripherals
- Wireless Terminals and Peripherals

## Features

- Isolation in the Powered-Off Mode,  $V_+ = 0$
- Specified Break-Before-Make Switching
- Low ON-State Resistance (1 Ω)
- Control Inputs Are 5.5-V Tolerant
- Low Charge Injection
- Excellent ON-State Resistance Matching
- Low Total Harmonic Distortion (THD)
- 1.65-V to 5.5-V Single-Supply Operation
- Latch-Up Performance Exceeds 100 mA Per JESD 78, Class II
- ESD Performance Tested Per JESD 22
  - 2000-V Human-Body Model (A114-B, Class II)
  - 1000-V Charged-Device Model (C101)

## Summary of Characteristics

$V_+ = 5\text{ V}$ ,  $T_A = 25^\circ\text{C}$

Configuration	2:1 Multiplexer/ Demultiplexer (SPDT)
Number of channels	1
ON-state resistance ( $r_{ON}$ )	1.1 Ω
ON-state resistance match ( $\Delta r_{ON}$ )	0.1 Ω
ON-state resistance flatness ( $r_{ON(\text{flat})}$ )	0.15 Ω
Turn-on/turn-off time ( $t_{ON}/t_{OFF}$ )	20 ns/15 ns
Break-before-make time ( $t_{BBM}$ )	12 ns
Charge injection ( $Q_C$ )	36 pC
Bandwidth (BW)	100 MHz
OFF isolation ( $O_{ISO}$ )	-65 dB at 1 MHz
Crosstalk ( $X_{TALK}$ )	-66 dB at 1 MHz
Total harmonic distortion (THD)	0.01%
Leakage current ( $I_{COM(OFF)}/I_{NO(OFF)}$ )	±20 nA
Power-supply current ( $I_+$ )	0.1 μA
Package option	8-pin SSOP, VSSOP, or DSBGA

SSOP OR VSSOP PACKAGE  
(TOP VIEW)

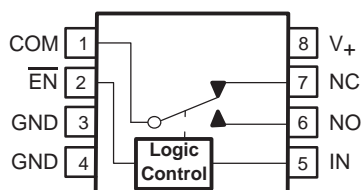

YEA, YEP, YZA, OR YZP PACKAGE  
(BOTTOM VIEW)

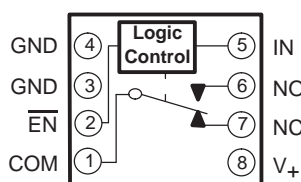

FUNCTION TABLE

$\overline{\text{EN}}$	IN	NC TO COM, COM TO NC	NO TO COM, COM TO NO
L	L	ON	OFF
L	H	OFF	ON
H	X	OFF	OFF



Please be aware that an important notice concerning availability, standard warranty, and use in critical applications of Texas Instruments semiconductor products and disclaimers thereto appears at the end of this data sheet.

**TS5A3153**  
**1-Ω SPDT ANALOG SWITCH**  
**5-V/3.3-V SINGLE-CHANNEL 2:1 MULTIPLEXER/DEMULTIPLEXER**



SCDS215 – OCTOBER 2005

**ORDERING INFORMATION**

TA	PACKAGE <sup>(1)</sup>		ORDERABLE PART NUMBER	TOP-SIDE MARKING <sup>(2)</sup>
-40°C to 85°C	NanoStar™ – WCSP (DSBGA) 0.17-mm Small Bump – YEA	Tape and reel	TS5A3153YEAR	PREVIEW
	NanoFree™ – WCSP (DSBGA) 0.17-mm Small Bump – YZA (Pb-free)		TS5A3153YZAR	PREVIEW
	NanoStar™ – WCSP (DSBGA) 0.23-mm Large Bump – YEP		TS5A3153YEPR	PREVIEW
	NanoFree™ – WCSP (DSBGA) 0.23-mm Large Bump – YZP (Pb-free)		TS5A3153YZPR	PREVIEW
	SSOP – DCT	Tape	TS5A3153DCT	PREVIEW
	VSSOP – DCU	Tape and reel	TS5A3153DCUR	JCD

(1) Package drawings, standard packing quantities, thermal data, symbolization, and PCB design guidelines are available at [www.ti.com/sc/package](http://www.ti.com/sc/package).

(2) DBV/DCK: The actual top-side marking has one additional character that designates the assembly/test site.

YEP/YZP: The actual top-side marking has three preceding characters to denote year, month, and sequence code, and one following character to designate the assembly/test site. Pin 1 identifier indicates solder-bump composition (1 = SnPb, ● = Pb-free).

**Absolute Minimum and Maximum Ratings<sup>(1)(2)</sup>**

over operating free-air temperature range (unless otherwise noted)

		MIN	MAX	UNIT
V <sub>+</sub>	Supply voltage range <sup>(3)</sup>	-0.5	6.5	V
V <sub>NC</sub> V <sub>NO</sub> V <sub>COM</sub>	Analog voltage range <sup>(3)(4)(5)</sup>	-0.5	V <sub>+</sub> + 0.5	V
I <sub>K</sub>	Analog port diode current V <sub>NC</sub> , V <sub>NO</sub> , V <sub>COM</sub> < 0	-50		mA
I <sub>NC</sub> I <sub>NO</sub> I <sub>COM</sub>	On-state switch current On-state peak switch current <sup>(6)</sup> V <sub>NC</sub> , V <sub>NO</sub> , V <sub>COM</sub> = 0 to V <sub>+</sub>	-200 -400	200 400	mA
V <sub>I</sub>	Digital input voltage range <sup>(3)(4)</sup>	-0.5	6.5	V
I <sub>I<sub>K</sub></sub>	Digital input clamp current V <sub>I</sub> < 0	-50		mA
I <sub>+</sub>	Continuous current through V <sub>+</sub>		100	mA
I <sub>GND</sub>	Continuous current through GND	-100	100	mA
θ <sub>JA</sub>	Package thermal impedance <sup>(7)</sup>	DCT package		°C/W
		DCU package		
		YEA/YZA package		
		YEP/YZP package		
T <sub>stg</sub>	Storage temperature range	-65	150	°C

(1) Stresses above these ratings may cause permanent damage. Exposure to absolute maximum conditions for extended periods may degrade device reliability. These are stress ratings only, and functional operation of the device at these or any other conditions beyond those specified is not implied.

(2) The algebraic convention, whereby the most negative value is a minimum and the most positive value is a maximum

(3) All voltages are with respect to ground, unless otherwise specified.

(4) The input and output voltage ratings may be exceeded if the input and output clamp-current ratings are observed.

(5) This value is limited to 5.5 V maximum.

(6) Pulse at 1 ms duration < 10% duty cycle

(7) The package thermal impedance is calculated in accordance with JESD 51-7.

### Electrical Characteristics for 5-V Supply<sup>(1)</sup>

V<sub>+</sub> = 4.5 V to 5.5 V, T<sub>A</sub> = -40°C to 85°C (unless otherwise noted)

PARAMETER	SYMBOL	TEST CONDITIONS	T <sub>A</sub>	V <sub>+</sub>	MIN	TYP	MAX	UNIT	
<b>Analog Switch</b>									
Analog signal range	V <sub>COM</sub> , V <sub>NO</sub> , V <sub>NC</sub>				0		V <sub>+</sub>	V	
Peak ON resistance	r <sub>peak</sub>	0 ≤ (V <sub>NO</sub> or V <sub>NC</sub> ) ≤ V <sub>+</sub> , I <sub>COM</sub> = -100 mA,	Switch ON, See Figure 13	25 °C Full	4.5 V	0.9	1.1 1.3	Ω	
ON-state resistance	r <sub>on</sub>	V <sub>NO</sub> or V <sub>NC</sub> = 2.5 V, I <sub>COM</sub> = 100 mA,	Switch ON, See Figure 13	25 °C Full	4.5 V	0.8	0.9 1.1	Ω	
ON-state resistance match between channels	Δr <sub>on</sub>	V <sub>NO</sub> or V <sub>NC</sub> = 2.5 V, I <sub>COM</sub> = 100 mA,	Switch ON, See Figure 13	25 °C Full	4.5 V	0.05	0.10 0.10	Ω	
ON-state resistance flatness	r <sub>on(flat)</sub>	0 ≤ (V <sub>NO</sub> or V <sub>NC</sub> ) ≤ V <sub>+</sub> , I <sub>COM</sub> = 100 mA,	Switch ON, See Figure 13	25 °C Full	4.5 V	0.15		Ω	
		V <sub>NO</sub> or V <sub>NC</sub> = 1 V, 1.5 V, 2.5 V, I <sub>COM</sub> = 100 mA,	Switch ON, See Figure 13	25 °C Full		0.09 0.15 0.15			
NC, NO OFF leakage current	I <sub>NC(OFF)</sub> , I <sub>NO(OFF)</sub>	V <sub>NC</sub> or V <sub>NO</sub> = 1 V, V <sub>COM</sub> = 4.5 V, or V <sub>NC</sub> or V <sub>NO</sub> = 4.5 V, V <sub>COM</sub> = 1 V,	Switch OFF, See Figure 14	25 °C Full	5.5 V	-20	2 20	nA	
		V <sub>NC</sub> or V <sub>NO</sub> = 0 to 5.5 V, V <sub>COM</sub> = 5.5 V to 0,	Switch OFF, See Figure 14	25 °C Full	0 V	-5	0.7 5	μA	
NC, NO ON leakage current	I <sub>NC(ON)</sub> , I <sub>NO(ON)</sub>	V <sub>NC</sub> or V <sub>NO</sub> = 1 V, V <sub>COM</sub> = Open, or V <sub>NC</sub> or V <sub>NO</sub> = 4.5 V, V <sub>COM</sub> = Open,	Switch ON, See Figure 15	25 °C Full	5.5 V	-20	2 20	nA	
						-150	150		
COM OFF leakage current	I <sub>COM(OFF)</sub>	V <sub>NC</sub> or V <sub>NO</sub> = 4.5 V, V <sub>COM</sub> = 1 V, or V <sub>NC</sub> or V <sub>NO</sub> = 1 V, V <sub>COM</sub> = 4.5 V,	Switch ON, See Figure 14	25 °C Full	5.5 V	-20	2 20	nA	
						-150	150		
COM ON leakage current	I <sub>COM(ON)</sub>	V <sub>NC</sub> or V <sub>NO</sub> = 0 to 5.5 V, V <sub>COM</sub> = 5.5 V to 0,	Switch OFF, See Figure 14	25 °C Full	0 V	-5	0.7 5	μA	
						-25	25		
COM ON leakage current	I <sub>COM(ON)</sub>	V <sub>NC</sub> or V <sub>NO</sub> = Open, V <sub>COM</sub> = 1 V, or V <sub>NC</sub> or V <sub>NO</sub> = Open, V <sub>COM</sub> = 4.5 V,	Switch ON, See Figure 15	25 °C Full	5.5 V	-20	2 20	nA	
						-150	150		
<b>Digital Control Inputs (IN, EN)<sup>(2)</sup></b>									
Input logic high	V <sub>IH</sub>			Full		2.4	5.5	V	
Input logic low	V <sub>IL</sub>			Full		0	0.8	V	
Input leakage current	I <sub>IH</sub> , I <sub>IL</sub>	V <sub>I</sub> = 5.5 V or 0		25 °C	5.5 V	-100	25	100	nA
				Full		-100	100		

(1) The algebraic convention, whereby the most negative value is a minimum and the most positive value is a maximum

(2) All unused digital inputs of the device must be held at V<sub>+</sub> or GND to ensure proper device operation. Refer to the TI application report, *Implications of Slow or Floating CMOS Inputs*, literature number SCBA004.

**TS5A3153**  
**1-Ω SPDT ANALOG SWITCH**  
**5-V/3.3-V SINGLE-CHANNEL 2:1 MULTIPLEXER/DEMULTIPLEXER**



SCDS215 – OCTOBER 2005

**Electrical Characteristics for 5-V Supply<sup>(1)</sup> (continued)**

$V_+ = 4.5\text{ V to }5.5\text{ V}$ ,  $T_A = -40^\circ\text{C to }85^\circ\text{C}$  (unless otherwise noted)

PARAMETER	SYMBOL	TEST CONDITIONS	$T_A$	$V_+$	MIN	TYP	MAX	UNIT	
<b>Dynamic</b>									
Turn-on time	$t_{ON}$	$V_{COM} = V_+$ , $R_L = 50\ \Omega$ ,	$C_L = 35\text{ pF}$ , See Figure 17	25°C	5 V	1	12.5	16	ns
				Full	4.5 V to 5.5 V	1		17.5	
Turn-off time	$t_{OFF}$	$V_{COM} = V_+$ , $R_L = 50\ \Omega$ ,	$C_L = 35\text{ pF}$ , See Figure 17	25°C	5 V	2.5	8.5	15	ns
				Full	4.5 V to 5.5 V	2		18	
Break-before-make time	$t_{BBM}$	$V_{NC} = V_{NO} = V_+$ , $R_L = 50\ \Omega$ ,	$C_L = 35\text{ pF}$ , See Figure 18	25°C	5 V	1	7	12	ns
				Full	4.5 V to 5.5 V	0.5		15	
Charge injection	$Q_C$	$V_{GEN} = 0$ , $R_{GEN} = 0$ , $C_L = 1\text{ nF}$ ,	See Figure 22	25°C	5 V		12	pC	
NC, NO OFF capacitance	$C_{NC(OFF)}$ , $C_{NO(OFF)}$	$V_{NC}$ or $V_{NO} = V_+$ or GND, Switch OFF,	See Figure 16	25°C	5 V		19	pF	
NC, NO ON capacitance	$C_{NC(ON)}$ , $C_{NO(ON)}$	$V_{NC}$ or $V_{NO} = V_+$ or GND, Switch ON,	See Figure 16	25°C	5 V		57	pF	
COM OFF capacitance	$C_{COM(OFF)}$	$V_{NC}$ or $V_{NO} = V_+$ or GND, Switch OFF,	See Figure 16	25°C	5 V		36	pF	
COM ON capacitance	$C_{COM(ON)}$	$V_{COM} = V_+$ or GND, Switch ON,	See Figure 16	25°C	5 V		57	pF	
Digital input capacitance	$C_I$	$V_I = V_+$ or GND,	See Figure 16	25°C	5 V		2	pF	
Bandwidth	BW	$R_L = 50\ \Omega$ , Switch ON,	See Figure 19	25°C	5 V		97	MHz	
OFF isolation	$O_{ISO}$	$R_L = 50\ \Omega$ , $f = 1\text{ MHz}$ ,	Switch OFF, See Figure 20	25°C	5 V		-64	dB	
Crosstalk	XTALK	$R_L = 50\ \Omega$ , $f = 1\text{ MHz}$ ,	Switch ON, See Figure 21	25°C	5 V		-64	dB	
Total harmonic distortion	THD	$R_L = 600\ \Omega$ , $C_L = 50\text{ pF}$ ,	$f = 20\text{ Hz to }20\text{ kHz}$ , See Figure 23	25°C	5 V		0.004	%	
<b>Supply</b>									
Positive supply current	$I_+$	$V_I = V_+$ or GND,	Switch ON or OFF	25°C	5.5 V	0.02	0.10	$\mu\text{A}$	
				Full			0.50		

(1) The algebraic convention, whereby the most negative value is a minimum and the most positive value is a maximum

### Electrical Characteristics for 3.3-V Supply<sup>(1)</sup>

$V_+ = 3\text{ V to }3.6\text{ V}$ ,  $T_A = -40^\circ\text{C to }85^\circ\text{C}$  (unless otherwise noted)

PARAMETER	SYMBOL	TEST CONDITIONS	$T_A$	$V_+$	MIN	TYP	MAX	UNIT
<b>Analog Switch</b>								
Analog signal range	$V_{COM}, V_{NO}, V_{NC}$				0		$V_+$	V
Peak ON resistance	$r_{peak}$	$0 \leq (V_{NO} \text{ or } V_{NC}) \leq V_+$ , $I_{COM} = -100\text{ mA}$ ,	Switch ON, See Figure 13	25°C Full	3 V	1.3	1.6 1.8	Ω
ON-state resistance	$r_{on}$	$V_{NO} \text{ or } V_{NC} = 2\text{ V}$ , $I_{COM} = 100\text{ mA}$ ,	Switch ON, See Figure 13	25°C Full	3 V	1.2	1.5 1.7	Ω
ON-state resistance match between channels	$\Delta r_{on}$	$V_{NO} \text{ or } V_{NC} = 2\text{ V}, 0.8\text{ V}$ $I_{COM} = 100\text{ mA}$ ,	Switch ON, See Figure 13	25°C Full	3 V	0.08	0.15 0.15	Ω
ON-state resistance flatness	$r_{on(flat)}$	$0 \leq (V_{NO} \text{ or } V_{NC}) \leq V_+$ , $I_{COM} = 100\text{ mA}$ ,	Switch ON, See Figure 13	25°C Full	3 V	0.2	0.09 0.15 0.15	Ω
NC, NO OFF leakage current	$I_{NO(OFF)}, I_{NC(OFF)}$	$V_{NC} \text{ or } V_{NO} = 1\text{ V}, V_{COM} = 3\text{ V}$ , or $V_{NC} \text{ or } V_{NO} = 3\text{ V}, V_{COM} = 1\text{ V}$ ,	Switch OFF, See Figure 14	25°C Full	3.6 V	-20	2 50	20 nA
	$I_{NO(PWROFF)}, I_{NC(PWROFF)}$	$V_{NC} \text{ or } V_{NO} = 0 \text{ to } 3.6\text{ V}$ , $V_{COM} = 3.6\text{ V to } 0$ ,	Switch OFF, See Figure 14	25°C Full	0 V	-1	0.2 15	1 μA
NC, NO ON leakage current	$I_{NC(ON)}, I_{NO(ON)}$	$V_{NC} \text{ or } V_{NO} = 1\text{ V}, V_{COM} = \text{Open}$ , or $V_{NC} \text{ or } V_{NO} = 3\text{ V}, V_{COM} = \text{Open}$ ,	Switch ON, See Figure 15	25°C Full	3.6 V	-20	2 50	20 nA
	COM OFF leakage current	$I_{COM(OFF)}$	$V_{NC} \text{ or } V_{NO} = 3\text{ V}, V_{COM} = 1\text{ V}$ , or $V_{NC} \text{ or } V_{NO} = 1\text{ V}, V_{COM} = 3\text{ V}$ ,	Switch ON, See Figure 14	25°C Full	3.6 V	-20	2 50
$I_{COM(PWROFF)}$		$V_{NC} \text{ or } V_{NO} = 3.6 \text{ to } 0\text{ V}$ , $V_{COM} = 0 \text{ to } 3.6\text{ V}$ ,	Switch OFF, See Figure 14	25°C Full	0 V	-1	0.2 15	1 μA
COM ON leakage current	$I_{COM(ON)}$	$V_{NC} \text{ or } V_{NO} = \text{Open}, V_{COM} = 1\text{ V}$ , or $V_{NC} \text{ or } V_{NO} = \text{Open}, V_{COM} = 3\text{ V}$ ,	Switch ON, See Figure 15	25°C	3.6 V	-20	2 50	20 nA
				Full				
<b>Digital Control Inputs (<math>I_N, \overline{EN}</math>)<sup>(2)</sup></b>								
Input logic high	$V_{IH}$			Full		2	5.5	V
Input logic low	$V_{IL}$			Full		0	0.8	V
Input leakage current	$I_{IH}, I_{IL}$	$V_I = 5.5\text{ V or } 0$		25°C	3.6 V	-100	25	100 nA
				Full				

(1) The algebraic convention, whereby the most negative value is a minimum and the most positive value is a maximum

(2) All unused digital inputs of the device must be held at  $V_+$  or GND to ensure proper device operation. Refer to the TI application report, *Implications of Slow or Floating CMOS Inputs*, literature number SCBA004.

**TS5A3153**  
**1-Ω SPDT ANALOG SWITCH**  
**5-V/3.3-V SINGLE-CHANNEL 2:1 MULTIPLEXER/DEMULTIPLEXER**



SCDS215 – OCTOBER 2005

**Electrical Characteristics for 3.3-V Supply<sup>(1)</sup> (continued)**

$V_+ = 3\text{ V to }3.6\text{ V}$ ,  $T_A = -40^\circ\text{C to }85^\circ\text{C}$  (unless otherwise noted)

PARAMETER	SYMBOL	TEST CONDITIONS	$T_A$	$V_+$	MIN	TYP	MAX	UNIT	
<b>Dynamic</b>									
Turn-on time	$t_{ON}$	$V_{COM} = V_+$ , $R_L = 50\ \Omega$ ,	$C_L = 35\text{ pF}$ , See Figure 17	25°C	3.3 V	1	17	22	ns
				Full	3 V to 3.6 V	1		24	
Turn-off time	$t_{OFF}$	$V_{COM} = V_+$ , $R_L = 50\ \Omega$ ,	$C_L = 35\text{ pF}$ , See Figure 17	25°C	3.3 V	4.3	9.5	16	ns
				Full	3 V to 3.6 V	4		19	
Break-before-make time	$t_{BBM}$	$V_{NC} = V_{NO} = V_+$ , $R_L = 50\ \Omega$ ,	$C_L = 35\text{ pF}$ , See Figure 18	25°C	3.3 V	2	12	22	ns
				Full	3 V to 3.6 V	1		25	
Charge injection	$Q_C$	$V_{GEN} = 0$ , $R_{GEN} = 0$ , $C_L = 1\text{ nF}$ ,	See Figure 22	25°C	3.3 V		8	pC	
NC, NO OFF capacitance	$C_{NC(OFF)}$ , $C_{NO(OFF)}$	$V_{NC}$ or $V_{NO} = V_+$ or GND, Switch OFF,	See Figure 16	25°C	3.3 V		19	pF	
NC, NO ON capacitance	$C_{NC(ON)}$ , $C_{NO(ON)}$	$V_{NC}$ or $V_{NO} = V_+$ or GND, Switch ON,	See Figure 16	25°C	3.3 V		57	pF	
COM OFF capacitance	$C_{COM(OFF)}$	$V_{NC}$ or $V_{NO} = V_+$ or GND, Switch OFF,	See Figure 16	25°C	3.3 V		36	pF	
COM ON capacitance	$C_{COM(ON)}$	$V_{COM} = V_+$ or GND, Switch ON,	See Figure 16	25°C	3.3 V		57	pF	
Digital input capacitance	$C_I$	$V_I = V_+$ or GND,	See Figure 16	25°C	3.3 V		2	pF	
Bandwidth	BW	$R_L = 50\ \Omega$ , Switch ON,	See Figure 19	25°C	3.3 V		97	MHz	
OFF isolation	$O_{ISO}$	$R_L = 50\ \Omega$ , $f = 1\text{ MHz}$ ,	Switch OFF, See Figure 20	25°C	3.3 V		-64	dB	
Crosstalk	X-TALK	$R_L = 50\ \Omega$ , $f = 1\text{ MHz}$ ,	Switch ON, See Figure 21	25°C	3.3 V		-64	dB	
Total harmonic distortion	THD	$R_L = 600\ \Omega$ , $C_L = 50\text{ pF}$ ,	$f = 20\text{ Hz to }20\text{ kHz}$ , See Figure 23	25°C	3.3 V		0.010	%	
<b>Supply</b>									
Positive supply current	$I_+$	$V_I = V_+$ or GND,	Switch ON or OFF	25°C	3.6 V	0.01	0.10	$\mu\text{A}$	
				Full			0.25		

(1) The algebraic convention, whereby the most negative value is a minimum and the most positive value is a maximum



### Electrical Characteristics for 2.5-V Supply<sup>(1)</sup>

V<sub>+</sub> = 2.3 V to 2.7 V, T<sub>A</sub> = -40°C to 85°C (unless otherwise noted)

PARAMETER	SYMBOL	TEST CONDITIONS	T <sub>A</sub>	V <sub>+</sub>	MIN	TYP	MAX	UNIT
<b>Analog Switch</b>								
Analog signal range	V <sub>COM</sub> , V <sub>NO</sub> , V <sub>NC</sub>				0		V <sub>+</sub>	V
Peak ON resistance	r <sub>peak</sub>	0 ≤ (V <sub>NO</sub> or V <sub>NC</sub> ) ≤ V <sub>+</sub> , I <sub>COM</sub> = -8 mA, Switch ON, See Figure 13	25°C Full	2.3 V		1.9	2.5 2.7	Ω
ON-state resistance	r <sub>on</sub>	V <sub>NO</sub> or V <sub>NC</sub> = 1.8 V, I <sub>COM</sub> = 8 mA, Switch ON, See Figure 13	25°C Full	2.3 V		1.6	2.1 2.5	Ω
ON-state resistance match between channels	Δr <sub>on</sub>	V <sub>NO</sub> or V <sub>NC</sub> = 0.8 V, I <sub>COM</sub> = 8 mA, Switch ON, See Figure 13	25°C Full	2.3 V		0.12	0.2 0.2	Ω
ON-state resistance flatness	r <sub>on(flat)</sub>	0 ≤ (V <sub>NO</sub> or V <sub>NC</sub> ) ≤ V <sub>+</sub> , I <sub>COM</sub> = 8 mA, Switch ON, See Figure 13	25°C Full	2.3 V		0.65		Ω
NC, NO OFF leakage current	I <sub>NO(OFF)</sub> , I <sub>NC(OFF)</sub>	V <sub>NC</sub> or V <sub>NO</sub> = 0.5 V, V <sub>COM</sub> = 2.2 V, or V <sub>NC</sub> or V <sub>NO</sub> = 2.2 V, V <sub>COM</sub> = 0.5 V, Switch OFF, See Figure 14	25°C	2.7 V	-20	2	20	nA
			Full		-50		50	
NC, NO ON leakage current	I <sub>NC(ON)</sub> , I <sub>NO(ON)</sub>	V <sub>NC</sub> or V <sub>NO</sub> = 0.5 V, V <sub>COM</sub> = Open, or V <sub>NC</sub> or V <sub>NO</sub> = 2.2 V, V <sub>COM</sub> = Open, Switch ON, See Figure 15	25°C	2.7 V	-20	2	20	nA
			Full		-50		50	
COM OFF leakage current	I <sub>COM(OFF)</sub>	V <sub>NC</sub> or V <sub>NO</sub> = 2.2 V, V <sub>COM</sub> = 0.5 V, or V <sub>NO</sub> = 0.5 V, V <sub>COM</sub> = 2.2 V, Switch ON, See Figure 14	25°C	2.7 V	-20	2	20	nA
			Full		-50		50	
COM ON leakage current	I <sub>COM(ON)</sub>	V <sub>NC</sub> or V <sub>NO</sub> = 2.7 V to 0, V <sub>COM</sub> = 0 to 2.7 V, Switch OFF, See Figure 14	25°C	0 V	-1	0.1	1	μA
			Full		-10		10	
COM ON leakage current	I <sub>COM(ON)</sub>	V <sub>NC</sub> or V <sub>NO</sub> = Open, V <sub>COM</sub> = 0.5 V, or V <sub>NC</sub> or V <sub>NO</sub> = Open, V <sub>COM</sub> = 2.2 V, Switch ON, See Figure 15	25°C	2.7 V	-20	2	20	nA
			Full		-50		50	
<b>Digital Control Inputs (IN, EN)<sup>(2)</sup></b>								
Input logic high	V <sub>IH</sub>		Full		1.8		5.5	V
Input logic low	V <sub>IL</sub>		Full		0		0.6	V
Input leakage current	I <sub>IH</sub> , I <sub>IL</sub>	V <sub>I</sub> = 5.5 V or 0	25°C	2.7 V	-100	25	100	nA
			Full		-100		100	

(1) The algebraic convention, whereby the most negative value is a minimum and the most positive value is a maximum

(2) All unused digital inputs of the device must be held at V<sub>+</sub> or GND to ensure proper device operation. Refer to the TI application report, *Implications of Slow or Floating CMOS Inputs*, literature number SCBA004.

**TS5A3153**  
**1-Ω SPDT ANALOG SWITCH**  
**5-V/3.3-V SINGLE-CHANNEL 2:1 MULTIPLEXER/DEMULTIPLEXER**



SCDS215 – OCTOBER 2005

**Electrical Characteristics for 2.5-V Supply<sup>(1)</sup> (continued)**

$V_+ = 2.3 \text{ V to } 2.7 \text{ V}$ ,  $T_A = -40^\circ\text{C to } 85^\circ\text{C}$  (unless otherwise noted)

PARAMETER	SYMBOL	TEST CONDITIONS	$T_A$	$V_+$	MIN	TYP	MAX	UNIT
<b>Dynamic</b>								
Turn-on time	$t_{ON}$	$V_{COM} = V_+$ , $R_L = 50 \Omega$ , $C_L = 35 \text{ pF}$ , See Figure 17	25°C	2.5 V	1.7	24	31	ns
			Full	2.3 V to 2.7 V	1.5		33.5	
Turn-off time	$t_{OFF}$	$V_{COM} = V_+$ , $R_L = 50 \Omega$ , $C_L = 35 \text{ pF}$ , See Figure 17	25°C	2.5 V	5.2	10.5	17	ns
			Full	2.3 V to 2.7 V	5		20	
Break-before-make time	$t_{BBM}$	$V_{NC} = V_{NO} = V_+$ , $R_L = 50 \Omega$ , $C_L = 35 \text{ pF}$ , See Figure 18	25°C	2.5 V	3	10	30	ns
			Full	2.3 V to 2.7 V	2		40	
Charge injection	$Q_C$	$V_{GEN} = 0$ , $R_{GEN} = 0$ , $C_L = 1 \text{ nF}$ , See Figure 22	25°C	2.5 V		6		pC
NC, NO OFF capacitance	$C_{NC(OFF)}$ , $C_{NO(OFF)}$	$V_{NC}$ or $V_{NO} = V_+$ or GND, Switch OFF, See Figure 16	25°C	2.5 V		19		pF
NC, NO ON capacitance	$C_{NC(ON)}$ , $C_{NO(ON)}$	$V_{NC}$ or $V_{NO} = V_+$ or GND, Switch ON, See Figure 16	25°C	2.5 V		57		pF
COM OFF capacitance	$C_{COM(OFF)}$	$V_{NC}$ or $V_{NO} = V_+$ or GND, Switch OFF, See Figure 16	25°C	2.5 V		36		pF
COM ON capacitance	$C_{COM(ON)}$	$V_{COM} = V_+$ or GND, Switch ON, See Figure 16	25°C	2.5 V		57		pF
Digital input capacitance	$C_I$	$V_I = V_+$ or GND, See Figure 16	25°C	2.5 V		2		pF
Bandwidth	BW	$R_L = 50 \Omega$ , Switch ON, See Figure 19	25°C	2.5 V		100		MHz
OFF isolation	$O_{ISO}$	$R_L = 50 \Omega$ , $f = 1 \text{ MHz}$ , Switch OFF, See Figure 20	25°C	2.5 V		-64		dB
Crosstalk	XTALK	$R_L = 50 \Omega$ , $f = 1 \text{ MHz}$ , Switch ON, See Figure 21	25°C	2.5 V		-64		dB
Total harmonic distortion	THD	$R_L = 600 \Omega$ , $C_L = 50 \text{ pF}$ , $f = 20 \text{ Hz to } 20 \text{ kHz}$ , See Figure 23	25°C	2.5 V		0.020		%
<b>Supply</b>								
Positive supply current	$I_+$	$V_I = V_+$ or GND, Switch ON or OFF	25°C	2.7 V	0.001	0.05		$\mu\text{A}$
			Full			0.15		

(1) The algebraic convention, whereby the most negative value is a minimum and the most positive value is a maximum



### Electrical Characteristics for 1.8-V Supply<sup>(1)</sup>

$V_+ = 1.65\text{ V to }1.95\text{ V}$ ,  $T_A = -40^\circ\text{C to }85^\circ\text{C}$  (unless otherwise noted)

PARAMETER	SYMBOL	TEST CONDITIONS	$T_A$	$V_+$	MIN	TYP	MAX	UNIT	
<b>Analog Switch</b>									
Analog signal range	$V_{COM}, V_{NO}, V_{NC}$				0		$V_+$	V	
Peak ON resistance	$r_{peak}$	$0 \leq (V_{NO} \text{ or } V_{NC}) \leq V_+$ , $I_{COM} = -2\text{ mA}$ ,	Switch ON, See Figure 13	25°C Full	1.65 V	5.2	15 20	Ω	
ON-state resistance	$r_{on}$	$V_{NO} \text{ or } V_{NC} = 1.5\text{ V}$ , $I_{COM} = 2\text{ mA}$ ,	Switch ON, See Figure 13	25°C Full	1.65 V	2	2.7 3.1	Ω	
ON-state resistance match between channels	$\Delta r_{on}$	$V_{NO} \text{ or } V_{NC} = 0.6\text{ V}, 1.5\text{ V}$ , $I_{COM} = 2\text{ mA}$ ,	Switch ON, See Figure 13	25°C Full	1.65 V	0.16	0.3 0.3	Ω	
ON-state resistance flatness	$r_{on(flat)}$	$0 \leq (V_{NO} \text{ or } V_{NC}) \leq V_+$ , $I_{COM} = 2\text{ mA}$ ,	Switch ON, See Figure 13	25°C Full	1.65 V	3	3 8	Ω	
NC, NO OFF leakage current	$I_{NO(OFF)}, I_{NC(OFF)}$	$V_{NC} \text{ or } V_{NO} = 0.3\text{ V}, V_{COM} = 1.65\text{ V}$ , or $V_{NC} \text{ or } V_{NO} = 1.65\text{ V}, V_{COM} = 0.3\text{ V}$ ,	Switch OFF, See Figure 14	25°C	1.95 V	-20	1.5	20	nA
				Full		-50		50	
NC, NO ON leakage current	$I_{NC(ON)}, I_{NO(ON)}$	$V_{NC} \text{ or } V_{NO} = 0 \text{ to } 1.95\text{ V}$ , $V_{COM} = 1.95\text{ V to } 0$ ,	Switch OFF, See Figure 14	25°C	0 V	-1	0.1	1	μA
				Full		-10		10	
COM OFF leakage current	$I_{COM(OFF)}$	$V_{NC} \text{ or } V_{NO} = 1.65\text{ V}, V_{COM} = 0.3\text{ V}$ , or $V_{NC} \text{ or } V_{NO} = 0.3\text{ V}, V_{COM} = 1.65\text{ V}$ ,	Switch ON, See Figure 14	25°C	1.95 V	-20	1.5	20	nA
				Full		-50		50	
COM ON leakage current	$I_{COM(ON)}$	$V_{NC} \text{ or } V_{NO} = 1.95\text{ V to } 0$ , $V_{COM} = 0 \text{ to } 1.95\text{ V}$ ,	Switch OFF, See Figure 14	25°C	0 V	-1	0.06	1	μA
				Full		-10		10	
COM ON leakage current	$I_{COM(ON)}$	$V_{NC} \text{ or } V_{NO} = \text{Open}, V_{COM} = 0.3\text{ V}$ , or $V_{NC} \text{ or } V_{NO} = \text{Open}, V_{COM} = 1.65\text{ V}$ ,	Switch ON, See Figure 15	25°C	1.95 V	-20	1.5	20	nA
				Full		-50		50	
<b>Digital Control Inputs (IN, EN)<sup>(2)</sup></b>									
Input logic high	$V_{IH}$			Full		1.5		5.5	V
Input logic low	$V_{IL}$			Full		0		0.6	V
Input leakage current	$I_{IH}, I_{IL}$	$V_I = 5.5\text{ V or } 0$		25°C	1.95 V	-100	25	100	nA
				Full		-100		100	

(1) The algebraic convention, whereby the most negative value is a minimum and the most positive value is a maximum

(2) All unused digital inputs of the device must be held at  $V_+$  or GND to ensure proper device operation. Refer to the TI application report, *Implications of Slow or Floating CMOS Inputs*, literature number SCBA004.

**TS5A3153**  
**1-Ω SPDT ANALOG SWITCH**  
**5-V/3.3-V SINGLE-CHANNEL 2:1 MULTIPLEXER/DEMULTIPLEXER**



SCDS215 – OCTOBER 2005

**Electrical Characteristics for 1.8-V Supply<sup>(1)</sup> (continued)**

$V_+ = 1.65\text{ V to }1.95\text{ V}$ ,  $T_A = -40^\circ\text{C to }85^\circ\text{C}$  (unless otherwise noted)

PARAMETER	SYMBOL	TEST CONDITIONS	$T_A$	$V_+$	MIN	TYP	MAX	UNIT	
<b>Dynamic</b>									
Turn-on time	$t_{ON}$	$V_{COM} = V_+$ , $R_L = 50\ \Omega$ ,	$C_L = 35\text{ pF}$ , See Figure 17	25°C	1.8 V	4.5	45	61	ns
				Full	1.65 V to 1.95 V	4		63	
Turn-off time	$t_{OFF}$	$V_{COM} = V_+$ , $R_L = 50\ \Omega$ ,	$C_L = 35\text{ pF}$ , See Figure 17	25°C	1.8 V	5.4	12	19	ns
				Full	1.65 V to 1.95 V	5		21	
Break-before-make time	$t_{BBM}$	$V_{NC} = V_{NO} = V_+$ , $R_L = 50\ \Omega$ ,	$C_L = 35\text{ pF}$ , See Figure 18	25°C	1.8 V	4	31	60	ns
				Full	1.65 V to 1.95 V	3		65	
Charge injection	$Q_C$	$V_{GEN} = 0$ , $R_{GEN} = 0$ , $C_L = 1\text{ nF}$ ,	See Figure 22	25°C	1.8 V		4	pC	
NC, NO OFF capacitance	$C_{NC(OFF)}$ , $C_{NO(OFF)}$	$V_{NC}$ or $V_{NO} = V_+$ or GND, Switch OFF,	See Figure 16	25°C	1.8 V		19	pF	
NC, NO ON capacitance	$C_{NC(ON)}$ , $C_{NO(ON)}$	$V_{NC}$ or $V_{NO} = V_+$ or GND, Switch ON,	See Figure 16	25°C	1.8 V		57	pF	
COM OFF capacitance	$C_{COM(OFF)}$	$V_{NC}$ or $V_{NO} = V_+$ or GND, Switch OFF,	See Figure 16	25°C	1.8 V		36	pF	
COM ON capacitance	$C_{COM(ON)}$	$V_{COM} = V_+$ or GND, Switch ON,	See Figure 16	25°C	1.8 V		57	pF	
Digital input capacitance	$C_I$	$V_I = V_+$ or GND,	See Figure 16	25°C	1.8 V		2	pF	
Bandwidth	BW	$R_L = 50\ \Omega$ , Switch ON,	See Figure 19	25°C	1.8 V		100	MHz	
OFF isolation	$O_{ISO}$	$R_L = 50\ \Omega$ , $f = 1\text{ MHz}$ ,	Switch OFF, See Figure 20	25°C	1.8 V		-64	dB	
Crosstalk	$X_{TALK}$	$R_L = 50\ \Omega$ , $f = 1\text{ MHz}$ ,	Switch ON, See Figure 21	25°C	1.8 V		-64	dB	
Total harmonic distortion	THD	$R_L = 600\ \Omega$ , $C_L = 50\text{ pF}$ ,	$f = 20\text{ Hz to }20\text{ kHz}$ , See Figure 23	25°C	1.8 V		0.060	%	
<b>Supply</b>									
Positive supply current	$I_+$	$V_I = V_+$ or GND,	Switch ON or OFF	25°C	1.95 V	0.001	0.05	$\mu\text{A}$	
				Full			0.1		

(1) The algebraic convention, whereby the most negative value is a minimum and the most positive value is a maximum

TYPICAL PERFORMANCE

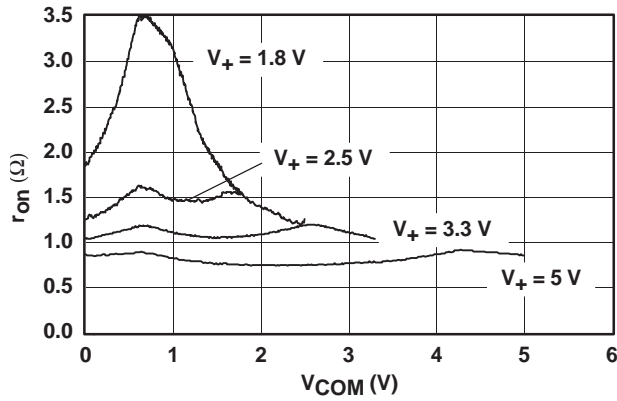

Figure 1.  $r_{on}$  vs  $V_{COM}$

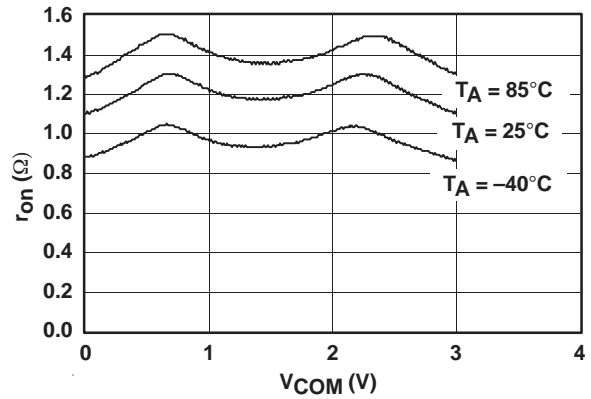

Figure 2.  $r_{on}$  vs  $V_{COM}$  ( $V_+ = 3$  V)

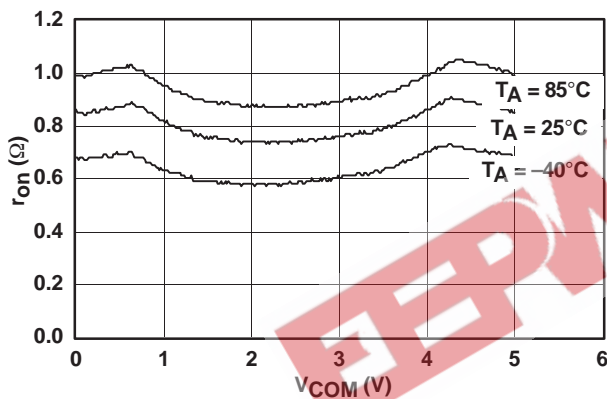

Figure 3.  $r_{on}$  vs  $V_{COM}$  ( $V_+ = 5$  V)

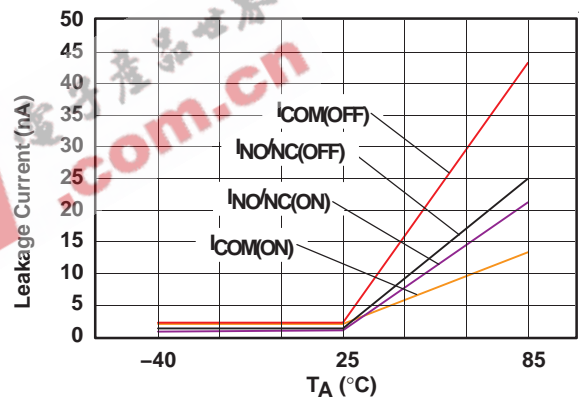

Figure 4. Leakage Current vs Temperature ( $V_+ = 5.5$  V)

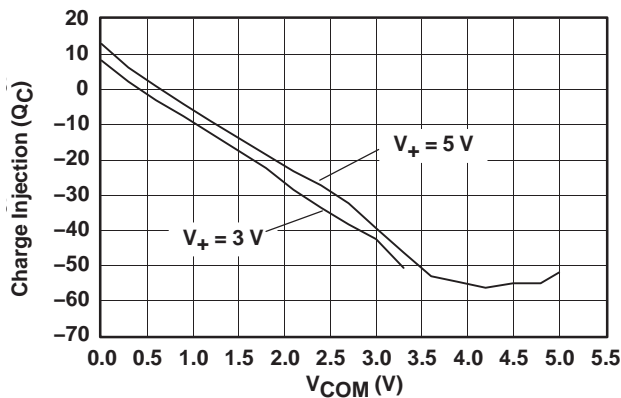

Figure 5. Charge Injection ( $Q_C$ ) vs  $V_{COM}$

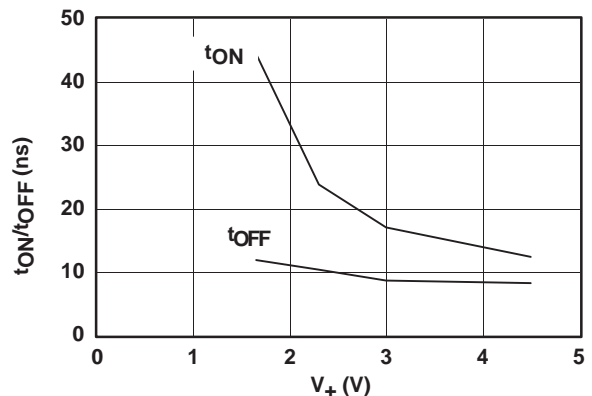

Figure 6.  $t_{ON}$  and  $t_{OFF}$  vs Supply Voltage

**TYPICAL PERFORMANCE**

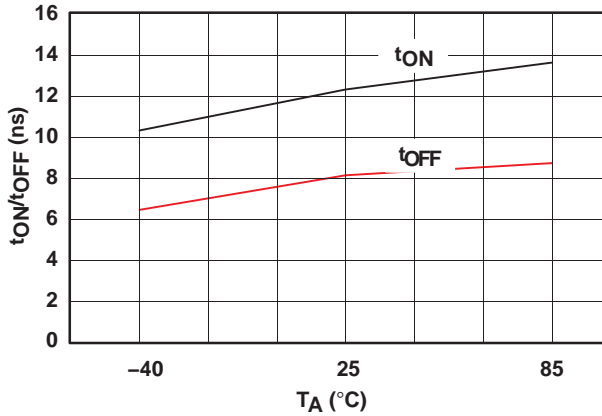

Figure 7.  $t_{ON}$  and  $t_{OFF}$  vs Temperature ( $V_+ = 4.5$  V)

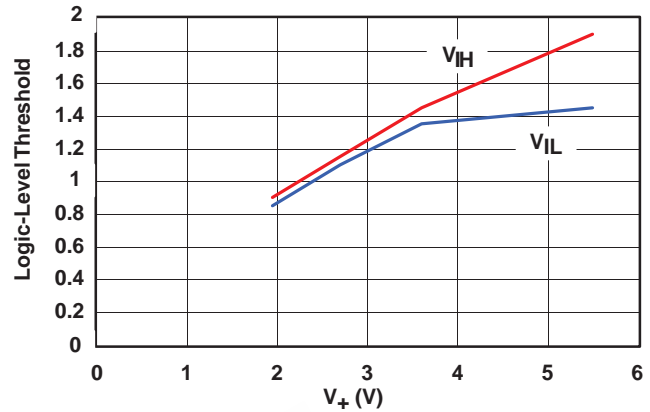

Figure 8. Logic-Level Threshold vs  $V_+$

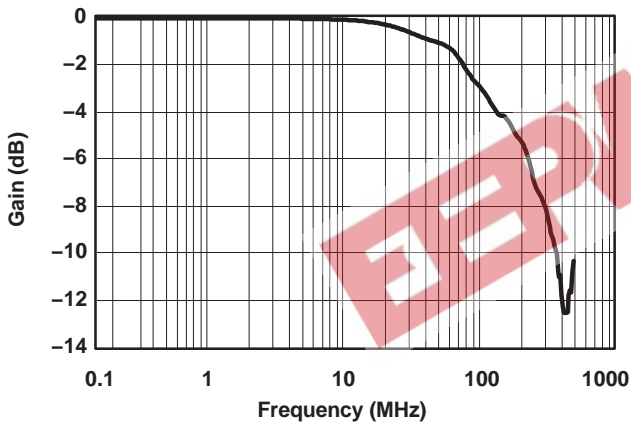

Figure 9. Bandwidth (Gain vs Frequency) ( $V_+ = 5$  V)

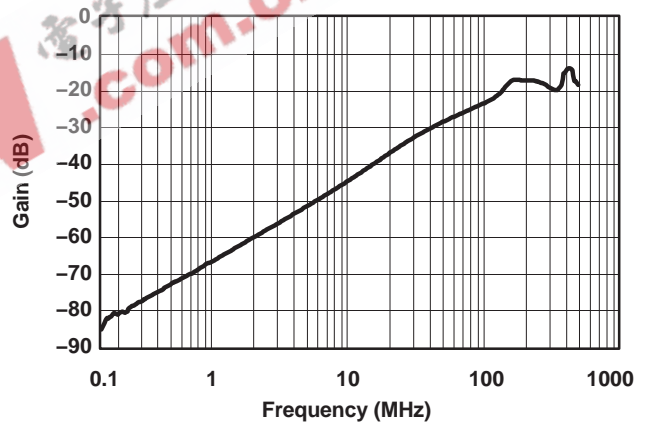

Figure 10. OFF Isolation vs Crosstalk ( $V_+ = 5$  V)

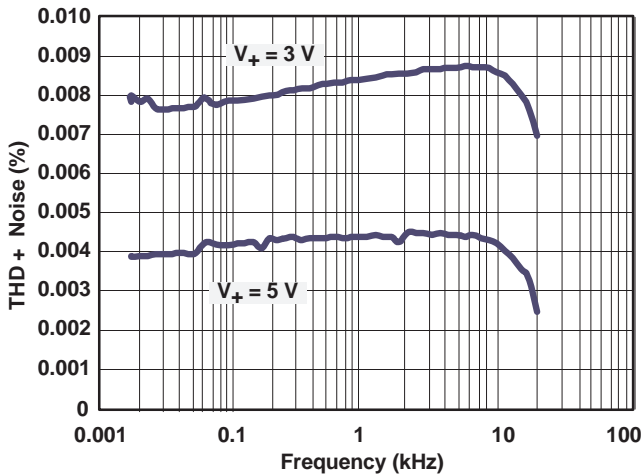

Figure 11. Total Harmonic Distortion vs Frequency

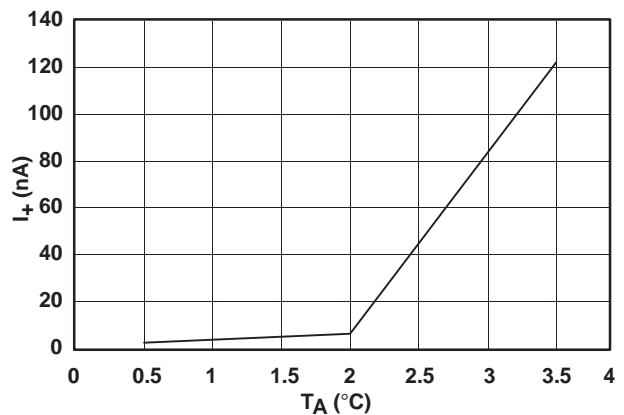

Figure 12. Power-Supply Current vs Temperature ( $V_+ = 5$  V)

**PIN DESCRIPTION**

PIN NUMBER	NAME	DESCRIPTION
1	COM	Common
2	$\overline{\text{EN}}$	Enable control input
3	GND	Digital ground
4	GND	Digital ground
5	IN	Digital control to connect COM to NO or NC
6	NO	Normally open
7	NC	Normally closed
8	V <sub>+</sub>	Power supply

**PARAMETER DESCRIPTION**

SYMBOL	DESCRIPTION
V <sub>COM</sub>	Voltage at COM
V <sub>NC</sub>	Voltage at NC
V <sub>NO</sub>	Voltage at NO
r <sub>on</sub>	Resistance between COM and NC or COM and NO ports when the channel is ON
r <sub>peak</sub>	Peak on-state resistance over a specified voltage range
Δr <sub>on</sub>	Difference of r <sub>on</sub> between channels in a specific device
r <sub>on(flat)</sub>	Difference between the maximum and minimum value of r <sub>on</sub> in a channel over the specified range of conditions
I <sub>NC(OFF)</sub>	Leakage current measured at the NC port, with the corresponding channel (NC to COM) in the OFF state under worst-case input and output conditions
I <sub>NC(PWROFF)</sub>	Leakage current measured at the NC port during the power-off condition, V <sub>+</sub> = 0
I <sub>NO(OFF)</sub>	Leakage current measured at the NO port, with the corresponding channel (NO to COM) in the OFF state under worst-case input and output conditions
I <sub>NO(PWROFF)</sub>	Leakage current measured at the NO port during the power-off condition, V <sub>+</sub> = 0
I <sub>NC(ON)</sub>	Leakage current measured at the NC port, with the corresponding channel (NC to COM) in the ON state and the output (COM) open
I <sub>NO(ON)</sub>	Leakage current measured at the NO port, with the corresponding channel (NO to COM) in the ON state and the output (COM) open
I <sub>COM(ON)</sub>	Leakage current measured at the COM port, with the corresponding channel (COM to NO or COM to NC) in the ON state and the output (NC or NO) open
I <sub>COM(OFF)</sub>	Leakage current measured at the COM port, with the corresponding channel (COM to NO or COM to NC) in the OFF state and the output (NC or NO) open
I <sub>COM(PWROFF)</sub>	Leakage current measured at the COM port during the power-off condition, V <sub>+</sub> = 0
V <sub>IH</sub>	Minimum input voltage for logic high for the control input (IN, $\overline{\text{EN}}$ )
V <sub>IL</sub>	Maximum input voltage for logic low for the control input (IN, $\overline{\text{EN}}$ )
V <sub>I</sub>	Voltage at the control input (IN, $\overline{\text{EN}}$ )
I <sub>IH</sub> , I <sub>IL</sub>	Leakage current measured at the control input (IN, $\overline{\text{EN}}$ )
t <sub>ON</sub>	Turn-on time for the switch. This parameter is measured under the specified range of conditions and by the propagation delay between the digital control (IN) signal and analog output (COM, NC, or NO) signal when the switch is turning ON.
t <sub>OFF</sub>	Turn-off time for the switch. This parameter is measured under the specified range of conditions and by the propagation delay between the digital control (IN) signal and analog output (COM, NC, or NO) signal when the switch is turning OFF.
t <sub>BBM</sub>	Break-before-make time. This parameter is measured under the specified range of conditions and by the propagation delay between the output of two adjacent analog channels (NC and NO) when the control signal changes state.
Q <sub>C</sub>	Charge injection is a measurement of unwanted signal coupling from the control (IN) input to the analog (NC, NO, or COM) output. This is measured in coulomb (C) and measured by the total charge induced due to switching of the control input. Charge injection, Q <sub>C</sub> = C <sub>L</sub> × ΔV <sub>COM</sub> , C <sub>L</sub> is the load capacitance, and ΔV <sub>COM</sub> is the change in analog output voltage.

**TS5A3153**  
**1-Ω SPDT ANALOG SWITCH**  
**5-V/3.3-V SINGLE-CHANNEL 2:1 MULTIPLEXER/DEMULTIPLEXER**



SCDS215 – OCTOBER 2005

**PARAMETER DESCRIPTION (continued)**

SYMBOL	DESCRIPTION
C <sub>NC(OFF)</sub>	Capacitance at the NC port when the corresponding channel (NC to COM) is OFF
C <sub>NO(OFF)</sub>	Capacitance at the NO port when the corresponding channel (NO to COM) is OFF
C <sub>NC(ON)</sub>	Capacitance at the NC port when the corresponding channel (NC to COM) is ON
C <sub>NO(ON)</sub>	Capacitance at the NO port when the corresponding channel (NO to COM) is ON
C <sub>COM(ON)</sub>	Capacitance at the COM port when the corresponding channel (COM to NC or COM to NO) is ON
C <sub>COM(OFF)</sub>	Capacitance at the COM port when the corresponding channel (COM to NC or COM to NO) is OFF
C <sub>I</sub>	Capacitance of control input (IN, $\overline{\text{EN}}$ )
O <sub>ISO</sub>	OFF isolation of the switch is a measurement of OFF-state switch impedance. This is measured in dB in a specific frequency, with the corresponding channel (NC to COM or NO to COM) in the OFF state.
X <sub>TALK</sub>	Crosstalk is a measurement of unwanted signal coupling from an ON channel to an OFF channel (NC to NO or NO to NC). This is measured in a specific frequency and in dB.
BW	Bandwidth of the switch. This is the frequency in which the gain of an ON channel is –3 dB below the DC gain.
THD	Total harmonic distortion describes the signal distortion caused by the analog switch. This is defined as the ratio of root mean square (RMS) value of the second, third, and higher harmonic to the absolute magnitude of the fundamental harmonic.
I <sub>+</sub>	Static power-supply current with the control (IN, $\overline{\text{EN}}$ ) pin at V <sub>+</sub> or GND

EEPW 电子產品世界 .com.cn

PARAMETER MEASUREMENT INFORMATION

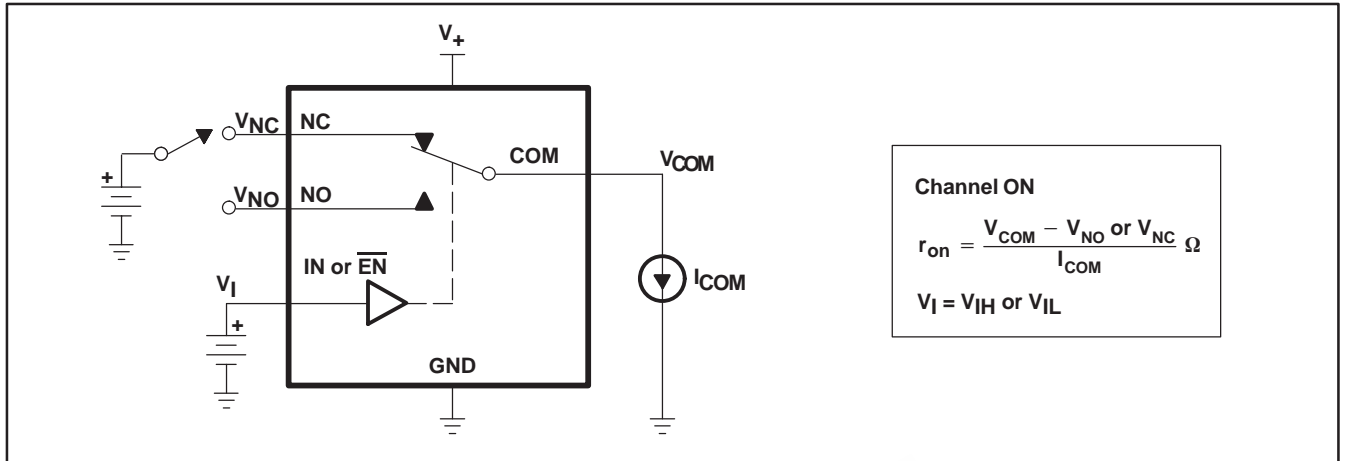

Figure 13. ON-State Resistance ( $r_{on}$ )

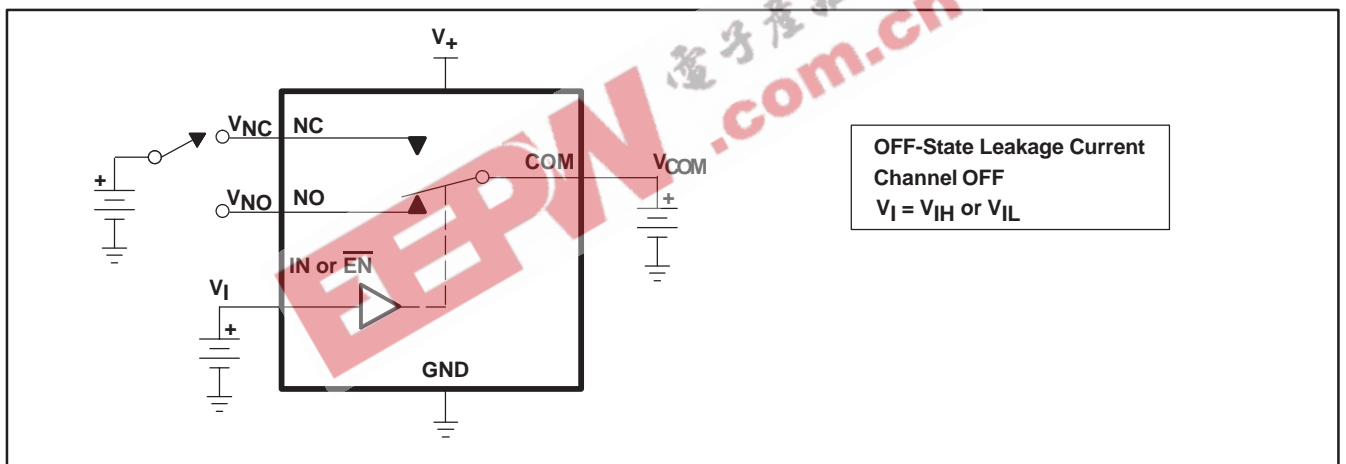

Figure 14. OFF-State Leakage Current ( $I_{NC(OFF)}$ ,  $I_{NC(PWROFF)}$ ,  $I_{NO(OFF)}$ ,  $I_{NO(PWROFF)}$ ,  $I_{COM(PWROFF)}$ )

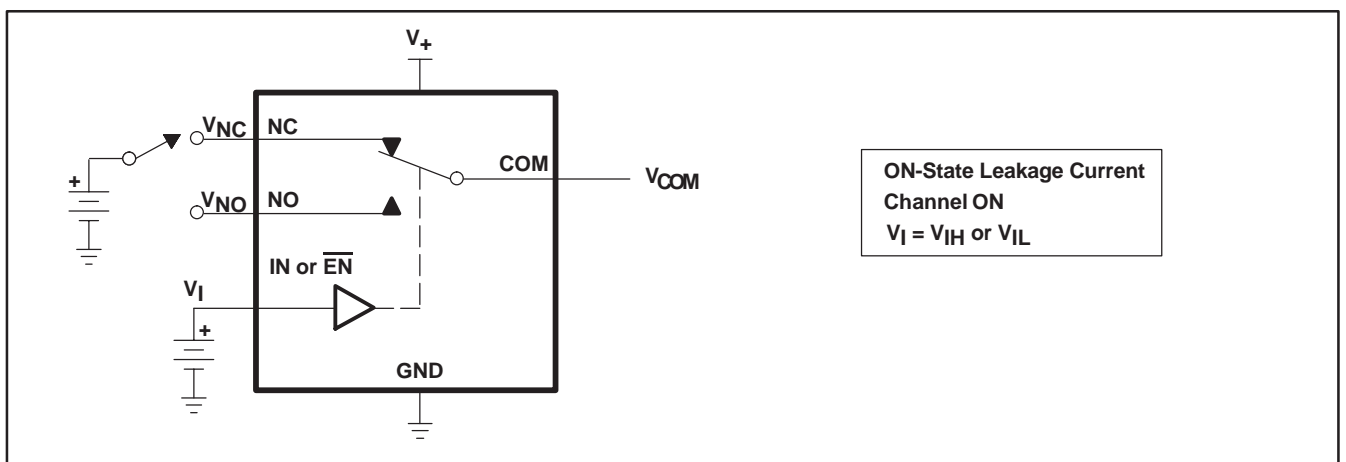

Figure 15. ON-State Leakage Current ( $I_{COM(ON)}$ ,  $I_{NC(ON)}$ ,  $I_{NO(ON)}$ )



**TS5A3153**  
**1-Ω SPDT ANALOG SWITCH**  
**5-V/3.3-V SINGLE-CHANNEL 2:1 MULTIPLEXER/DEMULTIPLEXER**

SCDS215 – OCTOBER 2005

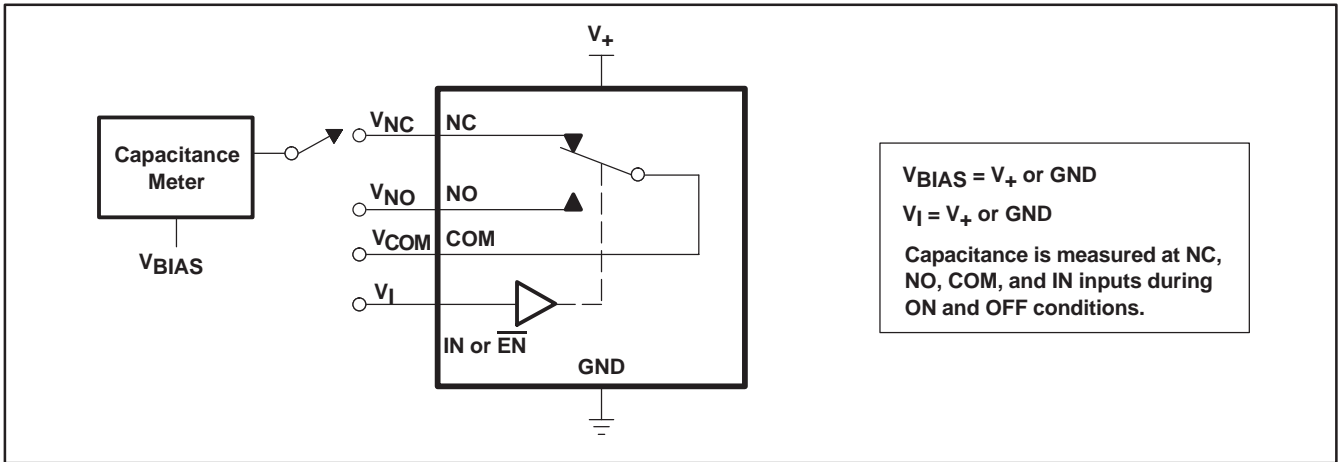
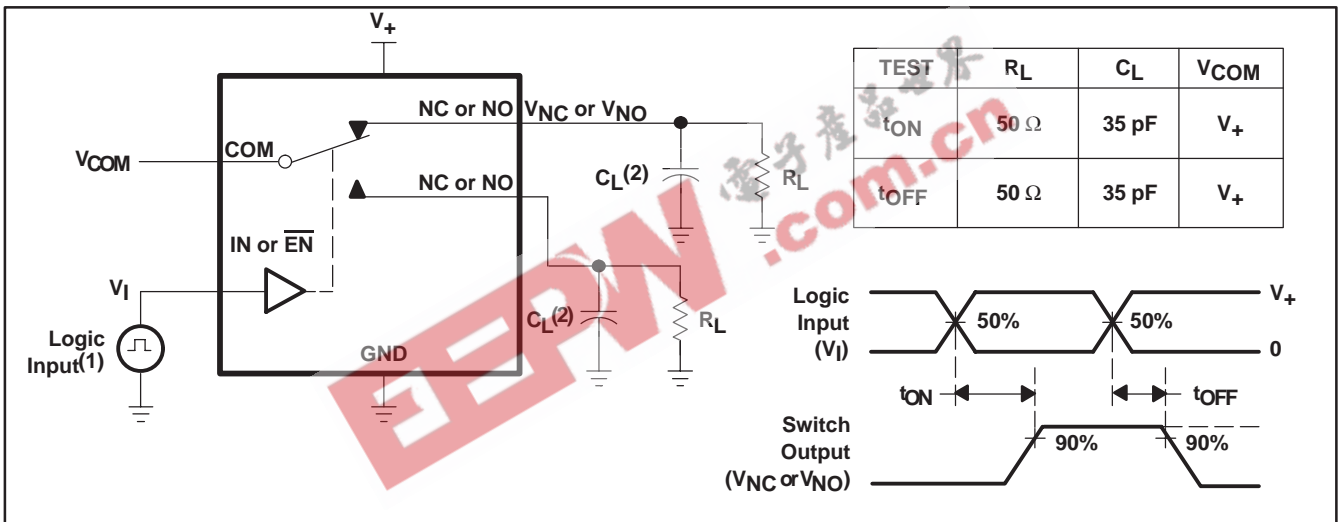
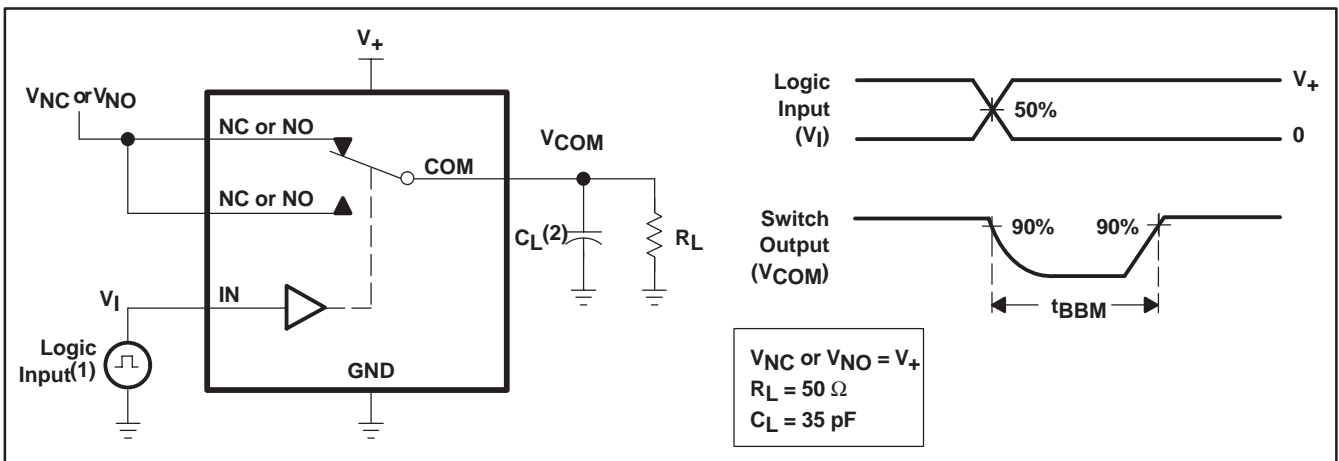

Figure 16. Capacitance ( $C_I$ ,  $C_{COM(OFF)}$ ,  $C_{COM(ON)}$ ,  $C_{NC(OFF)}$ ,  $C_{NO(OFF)}$ ,  $C_{NC(ON)}$ ,  $C_{NO(ON)}$ )



- (1) All input pulses are supplied by generators having the following characteristics: PRR ≤ 10 MHz, Z<sub>O</sub> = 50 Ω, t<sub>r</sub> < 5 ns, t<sub>f</sub> < 5 ns.
- (2) C<sub>L</sub> includes probe and jig capacitance.

Figure 17. Turn-On (t<sub>ON</sub>) and Turn-Off Time (t<sub>OFF</sub>)



- (1) All input pulses are supplied by generators having the following characteristics: PRR ≤ 10 MHz, Z<sub>O</sub> = 50 Ω, t<sub>r</sub> < 5 ns, t<sub>f</sub> < 5 ns.
- (2) C<sub>L</sub> includes probe and jig capacitance.

Figure 18. Break-Before-Make Time (t<sub>BBM</sub>)

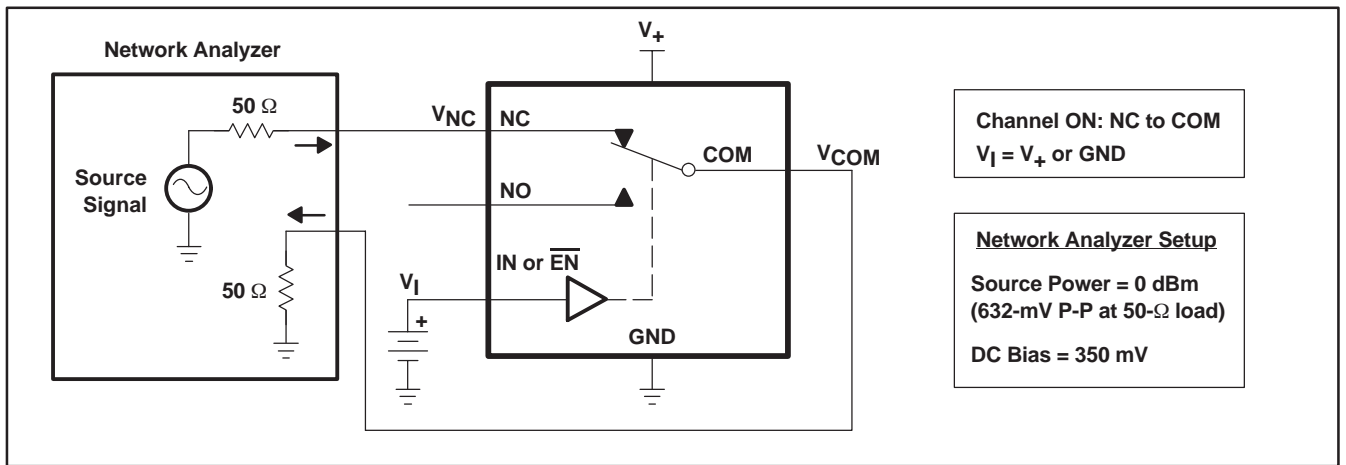

Figure 19. Bandwidth (BW)

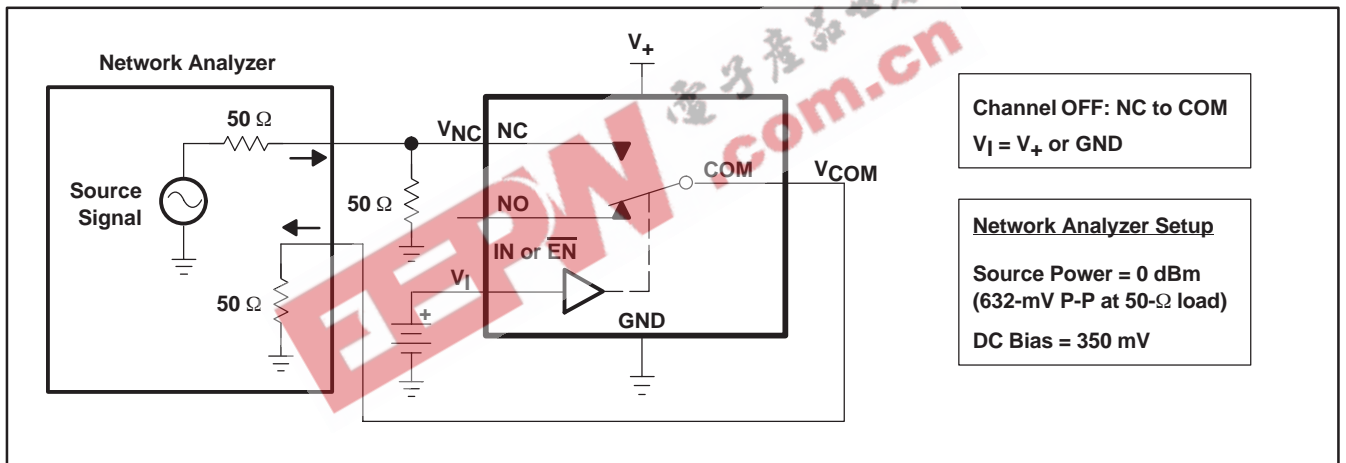

Figure 20. OFF Isolation ( $O_{ISO}$ )

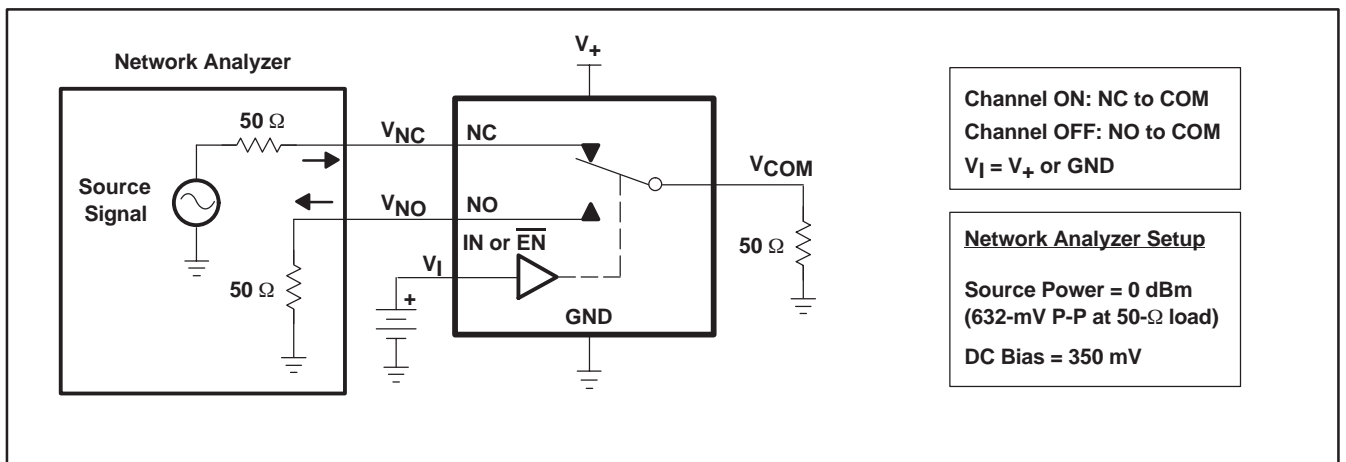
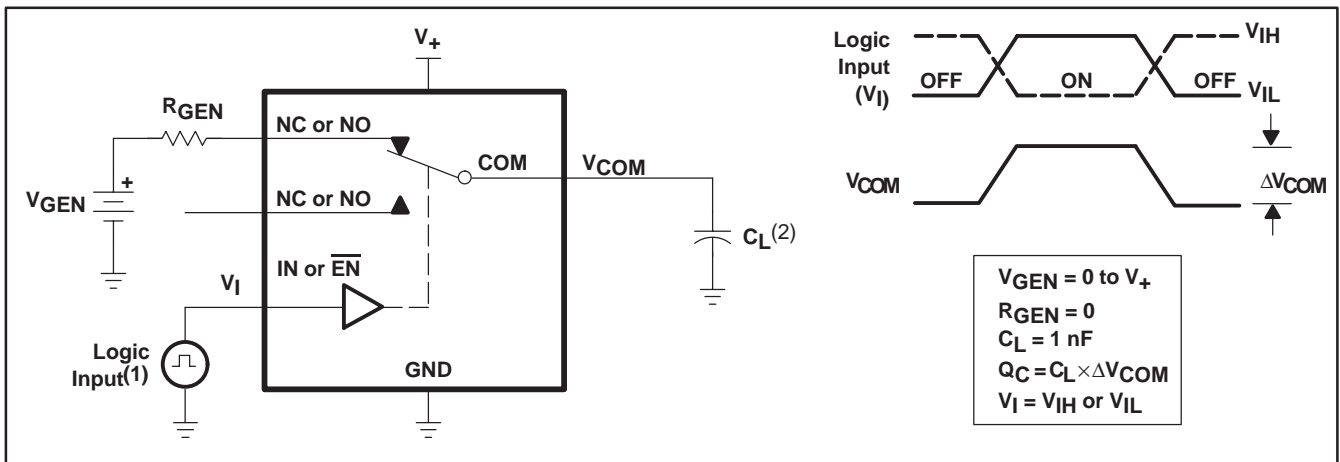

Figure 21. Crosstalk ( $X_{TALK}$ )

**TS5A3153**  
**1-Ω SPDT ANALOG SWITCH**  
**5-V/3.3-V SINGLE-CHANNEL 2:1 MULTIPLEXER/DEMULTIPLEXER**

SCDS215 – OCTOBER 2005



- (1) All input pulses are supplied by generators having the following characteristics: PRR  $\leq$  10 MHz,  $Z_O = 50 \Omega$ ,  $t_r < 5 \text{ ns}$ ,  $t_f < 5 \text{ ns}$ .  
 (2)  $C_L$  includes probe and jig capacitance.

Figure 22. Charge Injection ( $Q_C$ )

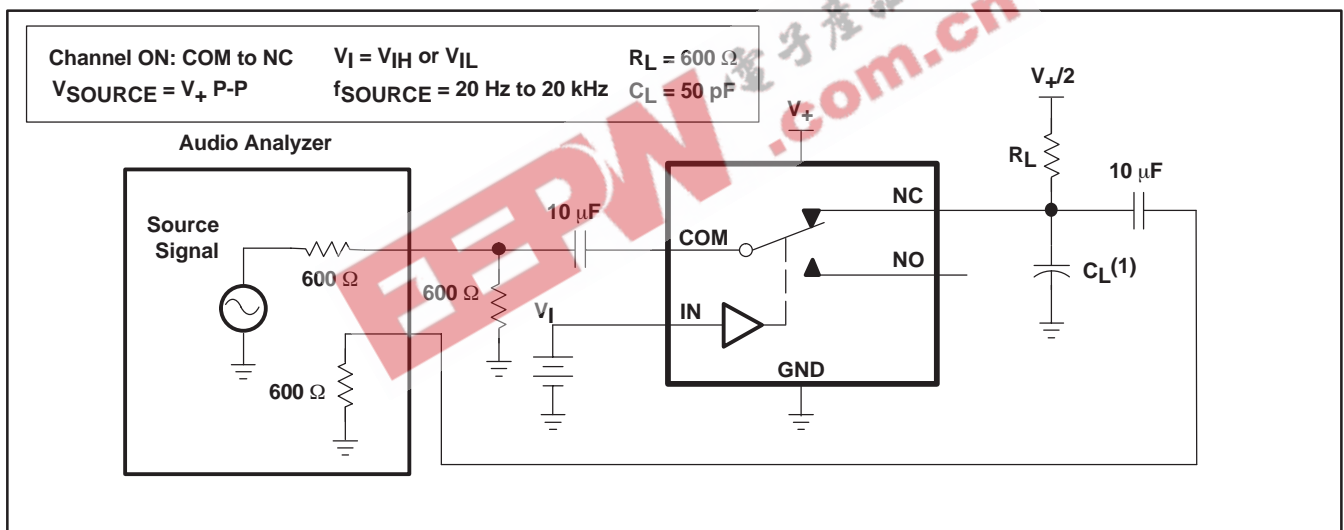

- (1)  $C_L$  includes probe and jig capacitance.

Figure 23. Total Harmonic Distortion (THD)

**PACKAGING INFORMATION**

Orderable Device	Status <sup>(1)</sup>	Package Type	Package Drawing	Pins	Package Qty	Eco Plan <sup>(2)</sup>	Lead/Ball Finish	MSL Peak Temp <sup>(3)</sup>
TS5A3153DCUR	ACTIVE	US8	DCU	8	3000	Pb-Free (RoHS)	CU NIPDAU	Level-1-260C-UNLIM
TS5A3153DCURE4	ACTIVE	US8	DCU	8	3000	Pb-Free (RoHS)	CU NIPDAU	Level-1-260C-UNLIM

<sup>(1)</sup> The marketing status values are defined as follows:

**ACTIVE:** Product device recommended for new designs.

**LIFEBUY:** TI has announced that the device will be discontinued, and a lifetime-buy period is in effect.

**NRND:** Not recommended for new designs. Device is in production to support existing customers, but TI does not recommend using this part in a new design.

**PREVIEW:** Device has been announced but is not in production. Samples may or may not be available.

**OBSOLETE:** TI has discontinued the production of the device.

<sup>(2)</sup> Eco Plan - The planned eco-friendly classification: Pb-Free (RoHS) or Green (RoHS & no Sb/Br) - please check <http://www.ti.com/productcontent> for the latest availability information and additional product content details.

**TBD:** The Pb-Free/Green conversion plan has not been defined.

**Pb-Free (RoHS):** TI's terms "Lead-Free" or "Pb-Free" mean semiconductor products that are compatible with the current RoHS requirements for all 6 substances, including the requirement that lead not exceed 0.1% by weight in homogeneous materials. Where designed to be soldered at high temperatures, TI Pb-Free products are suitable for use in specified lead-free processes.

**Green (RoHS & no Sb/Br):** TI defines "Green" to mean Pb-Free (RoHS compatible), and free of Bromine (Br) and Antimony (Sb) based flame retardants (Br or Sb do not exceed 0.1% by weight in homogeneous material)

<sup>(3)</sup> MSL, Peak Temp. -- The Moisture Sensitivity Level rating according to the JEDEC industry standard classifications, and peak solder temperature.

**Important Information and Disclaimer:** The information provided on this page represents TI's knowledge and belief as of the date that it is provided. TI bases its knowledge and belief on information provided by third parties, and makes no representation or warranty as to the accuracy of such information. Efforts are underway to better integrate information from third parties. TI has taken and continues to take reasonable steps to provide representative and accurate information but may not have conducted destructive testing or chemical analysis on incoming materials and chemicals. TI and TI suppliers consider certain information to be proprietary, and thus CAS numbers and other limited information may not be available for release.

In no event shall TI's liability arising out of such information exceed the total purchase price of the TI part(s) at issue in this document sold by TI to Customer on an annual basis.

MECHANICAL DATA

DCU (R-PDSO-G8)

PLASTIC SMALL-OUTLINE PACKAGE (DIE DOWN)

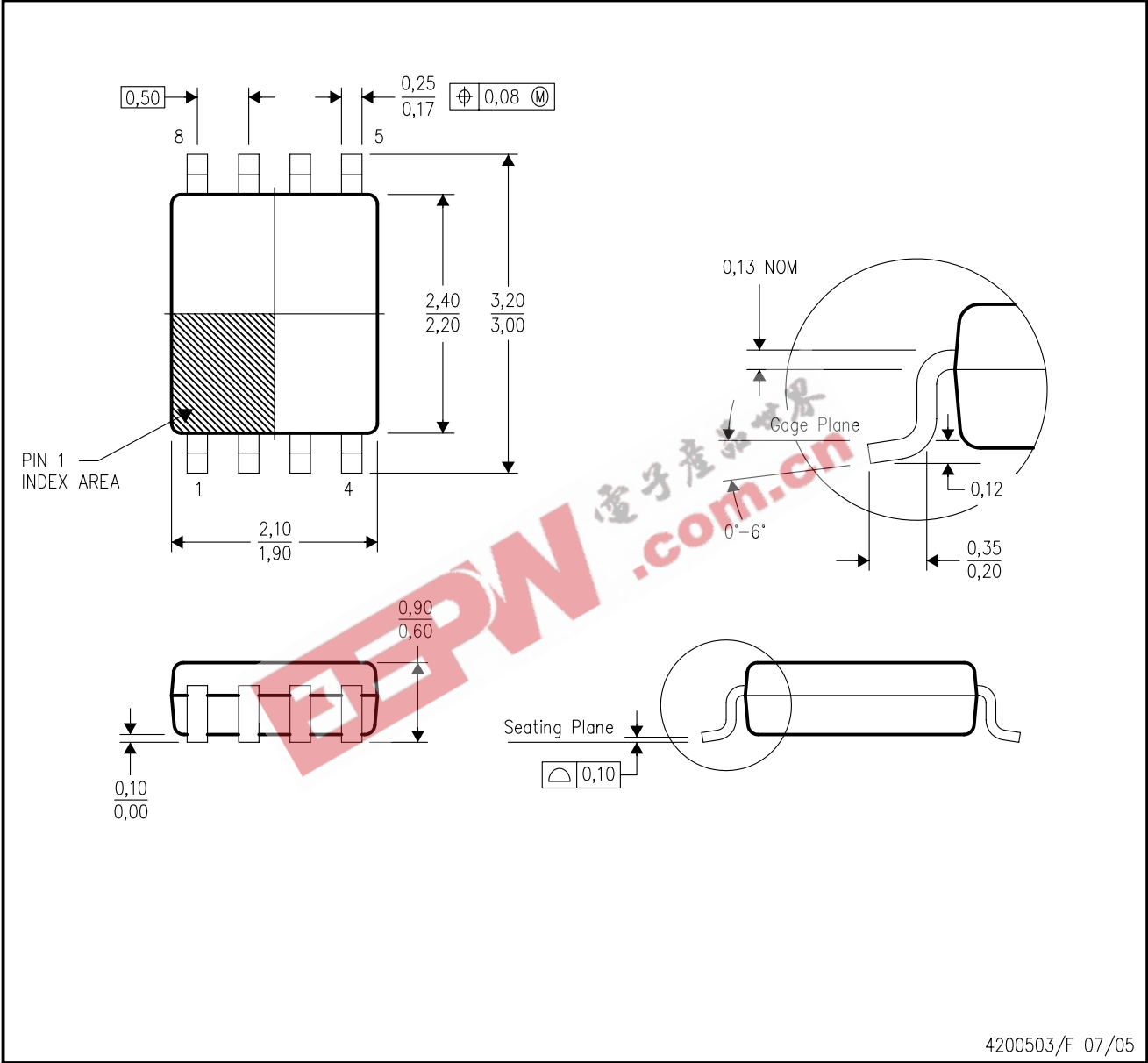

4200503/F 07/05

- NOTES:
- A. All linear dimensions are in millimeters.
  - B. This drawing is subject to change without notice.
  - C. Body dimensions do not include mold flash or protrusion. Mold flash and protrusion shall not exceed 0.15 per side.
  - D. Falls within JEDEC MO-187 variation CA.

## IMPORTANT NOTICE

Texas Instruments Incorporated and its subsidiaries (TI) reserve the right to make corrections, modifications, enhancements, improvements, and other changes to its products and services at any time and to discontinue any product or service without notice. Customers should obtain the latest relevant information before placing orders and should verify that such information is current and complete. All products are sold subject to TI's terms and conditions of sale supplied at the time of order acknowledgment.

TI warrants performance of its hardware products to the specifications applicable at the time of sale in accordance with TI's standard warranty. Testing and other quality control techniques are used to the extent TI deems necessary to support this warranty. Except where mandated by government requirements, testing of all parameters of each product is not necessarily performed.

TI assumes no liability for applications assistance or customer product design. Customers are responsible for their products and applications using TI components. To minimize the risks associated with customer products and applications, customers should provide adequate design and operating safeguards.

TI does not warrant or represent that any license, either express or implied, is granted under any TI patent right, copyright, mask work right, or other TI intellectual property right relating to any combination, machine, or process in which TI products or services are used. Information published by TI regarding third-party products or services does not constitute a license from TI to use such products or services or a warranty or endorsement thereof. Use of such information may require a license from a third party under the patents or other intellectual property of the third party, or a license from TI under the patents or other intellectual property of TI.

Reproduction of information in TI data books or data sheets is permissible only if reproduction is without alteration and is accompanied by all associated warranties, conditions, limitations, and notices. Reproduction of this information with alteration is an unfair and deceptive business practice. TI is not responsible or liable for such altered documentation.

Resale of TI products or services with statements different from or beyond the parameters stated by TI for that product or service voids all express and any implied warranties for the associated TI product or service and is an unfair and deceptive business practice. TI is not responsible or liable for any such statements.

Following are URLs where you can obtain information on other Texas Instruments products and application solutions:

<b>Products</b>		<b>Applications</b>	
Amplifiers	<a href="http://amplifier.ti.com">amplifier.ti.com</a>	Audio	<a href="http://www.ti.com/audio">www.ti.com/audio</a>
Data Converters	<a href="http://dataconverter.ti.com">dataconverter.ti.com</a>	Automotive	<a href="http://www.ti.com/automotive">www.ti.com/automotive</a>
DSP	<a href="http://dsp.ti.com">dsp.ti.com</a>	Broadband	<a href="http://www.ti.com/broadband">www.ti.com/broadband</a>
Interface	<a href="http://interface.ti.com">interface.ti.com</a>	Digital Control	<a href="http://www.ti.com/digitalcontrol">www.ti.com/digitalcontrol</a>
Logic	<a href="http://logic.ti.com">logic.ti.com</a>	Military	<a href="http://www.ti.com/military">www.ti.com/military</a>
Power Mgmt	<a href="http://power.ti.com">power.ti.com</a>	Optical Networking	<a href="http://www.ti.com/opticalnetwork">www.ti.com/opticalnetwork</a>
Microcontrollers	<a href="http://microcontroller.ti.com">microcontroller.ti.com</a>	Security	<a href="http://www.ti.com/security">www.ti.com/security</a>
		Telephony	<a href="http://www.ti.com/telephony">www.ti.com/telephony</a>
		Video & Imaging	<a href="http://www.ti.com/video">www.ti.com/video</a>
		Wireless	<a href="http://www.ti.com/wireless">www.ti.com/wireless</a>

Mailing Address: Texas Instruments  
Post Office Box 655303 Dallas, Texas 75265