



FEATURES

- RoHS compliant
- UL 94V-0 Package Material
- Isolation to 4kVrms
- Compact Footprint
- PCB Mounting
- Backward compatible with Sn/Pb soldering systems

DESCRIPTION

The 1000 series are intended for wideband and pulse operations. They are also suitable for signal isolation and use in small isolated power supplies. The compact footprint makes them ideal for applications where space is at a premium.

SELECTION GUIDE¹

Order Code	Turns Ratio ±2%	Min. Primary Inductance	Min. Primary Constant, E _r	Max. Leakage Inductance	Max. Interwinding Capacitance	Max. DC Resistance Primary Winding	Max. DC Resistance Secondary 1 winding	Max. DC Resistance Secondary 2 winding	Isolation Voltage	Pin Connection Style	Mechanical Dimensions
		mH	Vμs	μH	pF	Ω	Ω	Ω			
1001C	1:1	3.0	200	22	23	1.2	1.0	-	2000	A	2
1002C	1:1:1	3.0	200	9	28	1.4	1.3	1.7	2000	B	1
1003C	2:1:1	12	400	35	30	4.0	1.8	2.4	2000	B	1
1007C	1:1:1	7.4	310	20	55	2.9	2.5	3.4	2000	B	1
1009C	1:1:1	22	550	85	18	10.6	8.9	12.2	2000	B	1
1013C	1:1:1	3.0	200	3	280	1.3	1.3	1.3	500V _{DC}	B	1
1016C	1:1	3.0	200	22	23	1.2	1.0	-	3500	A	2
1017C	1:1	0.8	130	4	20	0.4	0.3	-	4000	A	2
1024C	1.2CT:1CT	8.8	340	60	25	2.5	2.5	-	2000	C	1
1025C	2:1:1	24	570	70	20	7.5	3.5	4.5	2000	B	1
1026C	1:1:1	6.0	285	30	30	4.0	4.0	4.0	2000	B	1
1082C	100:1	6.1	280	-	6	0.7	0.1	-	2000	A	2

ABSOLUTE MAXIMUM RATINGS

Operating free air temperature range	0°C to 70°C
Storage temperature range	-60°C to 125°C

SOLDERING INFORMATION¹

Peak wave solder temperature	300°C for 10 seconds
Pin finish	Matte tin

¹ For further information, please visit www.murata-ps.com/rohs

All specifications typical at T_a=25°C.

TUBE DIMENSIONS

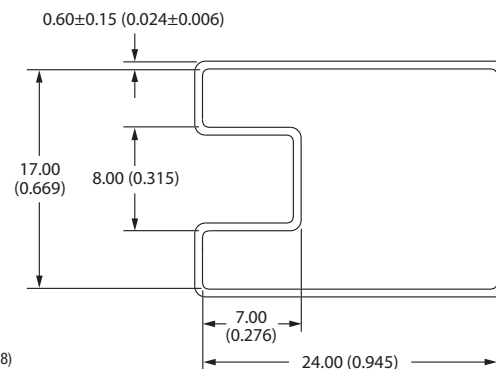

All dimensions in mm (inches).
 Tube length: 480±2mm (18.9±0.08)
 Tube quantity: 30



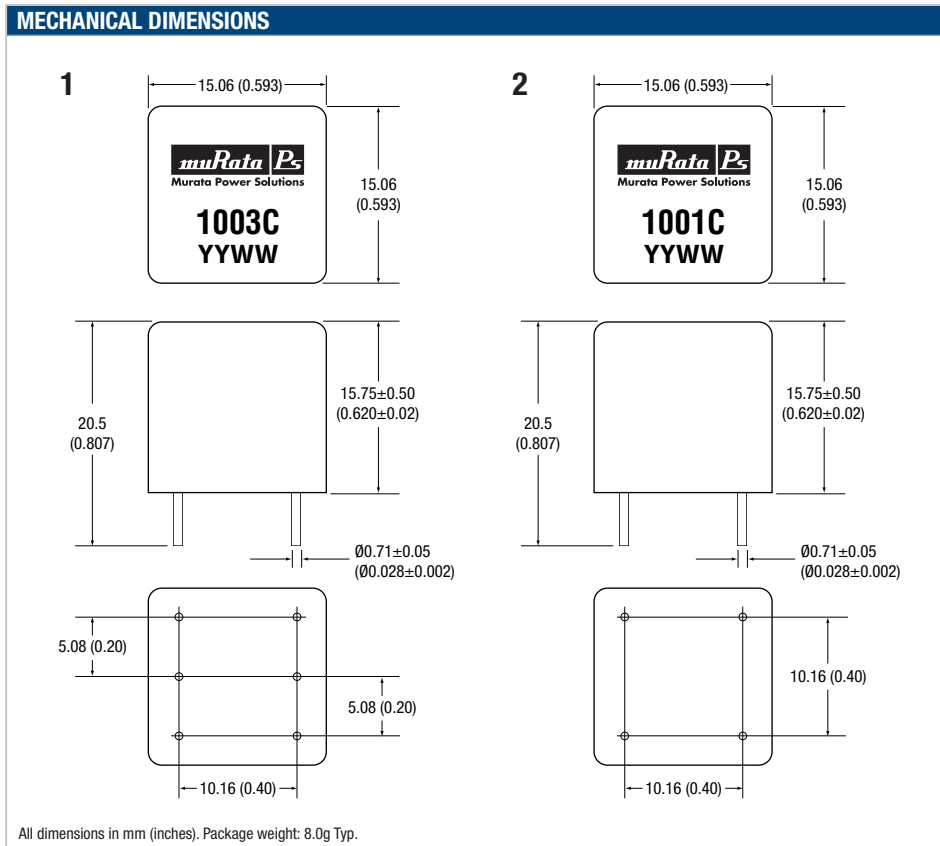
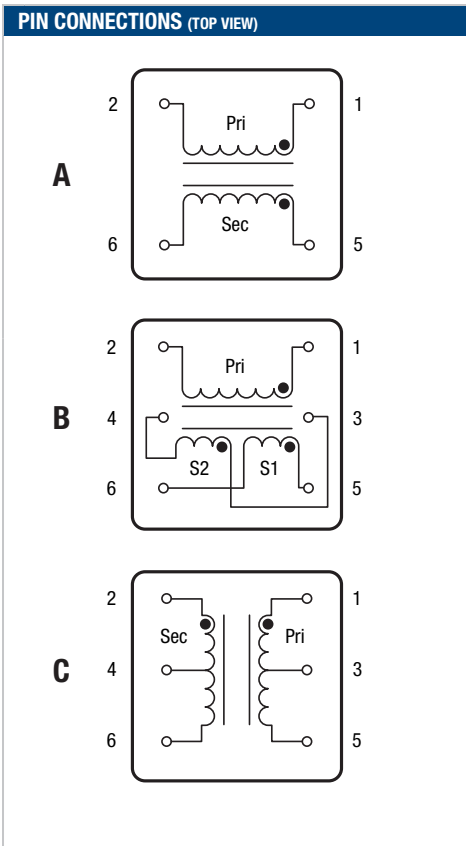

TECHNICAL NOTES

ISOLATION VOLTAGE

‘Hi Pot Test’, ‘Flash Tested’, ‘Withstand Voltage’, ‘Proof Voltage’, ‘Dielectric Withstand Voltage’ & ‘Isolation Test Voltage’ are all terms that relate to the same thing, a test voltage, applied for a specified time, across a component designed to provide electrical isolation, to verify the integrity of that isolation.

All products in this series are 100% production tested at their stated isolation voltage.

A question commonly asked is, “What is the continuous voltage that can be applied across the part in normal operation?”

For a part holding no specific agency approvals both input and output should normally be maintained within SELV limits i.e. less than 42.4V peak, or 60VDC. The isolation test voltage represents a measure of immunity to transient voltages and the part should never be used as an element of a safety isolation system. The part could be expected to function correctly with several hundred volts offset applied continuously across the isolation barrier; but then the circuitry on both sides of the barrier must be regarded as operating at an unsafe voltage and further isolation/insulation systems must form a barrier between these circuits and any user-accessible circuitry according to safety standard requirements.

REPEATED HIGH-VOLTAGE ISOLATION TESTING

It is well known that repeated high-voltage isolation testing of a barrier component can actually degrade isolation capability, to a lesser or greater degree depending on materials, construction and environment. While parts can be expected to withstand several times the stated test voltage, the isolation capability does depend on the insulative materials used. Such materials are susceptible to chemical degradation when subject to very high applied voltages. We therefore strongly advise against repeated high voltage isolation testing, but if it is absolutely required, that the voltage be reduced by 20% from specified test voltage.

This consideration equally applies to agency recognized parts rated for better than functional isolation where wire enamel insulation is always supplemented by a further insulation system of physical spacing or barriers.