

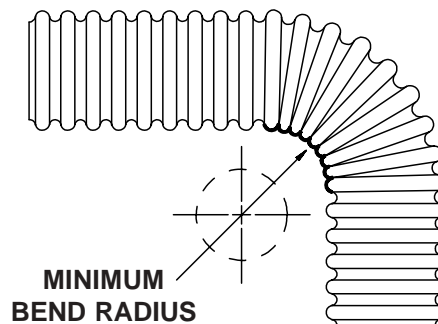

**121-103 - Type F**  
**Series 74 Helical Convuluted Tubing (MIL-T-81914) Natural or Black PFA, FEP, PTFE, Tefzel® (ETFE) or PEEK**

**TYPE F**  
**JACKET AND TWO EXTERNAL SHIELDS**

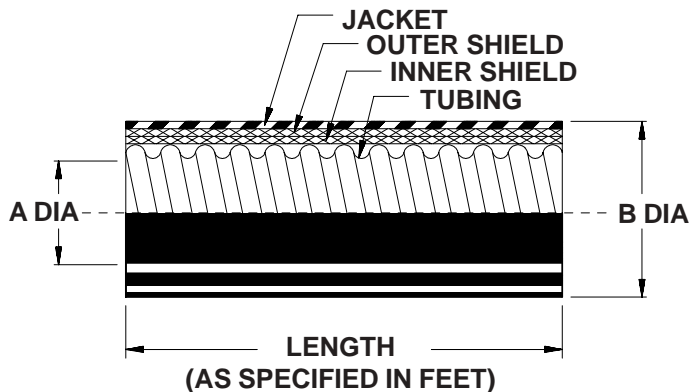
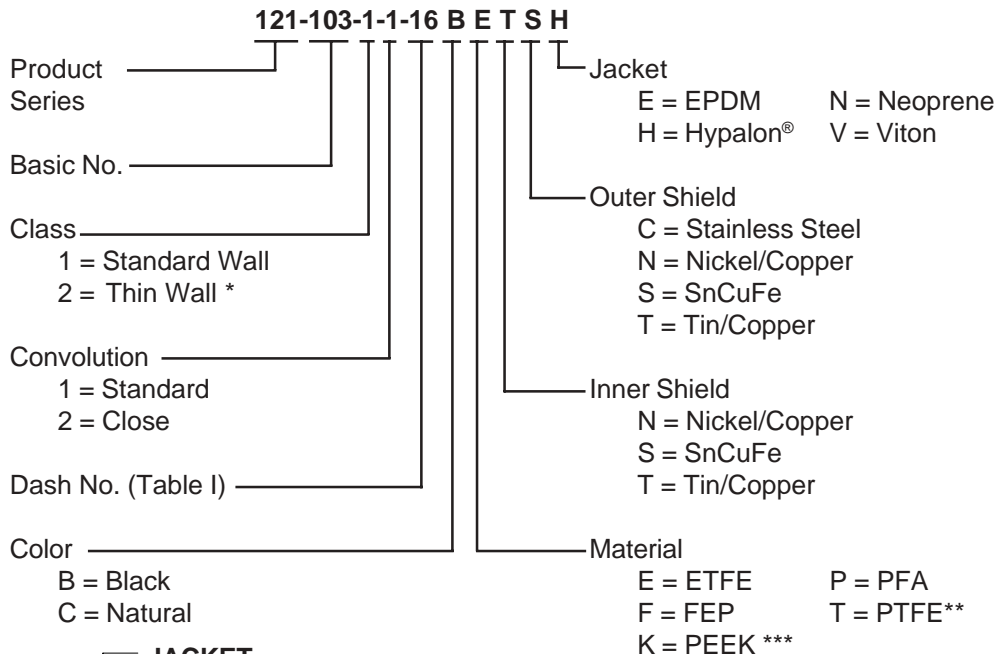

**TABLE I**

| DASH NO. | FRACTIONAL SIZE REF | A INSIDE DIA MIN | B DIA MAX    | MINIMUM BEND RADIUS * |
|----------|---------------------|------------------|--------------|-----------------------|
| 06       | 3/16                | .181 (4.6)       | .540 (13.7)  | .50 (12.7)            |
| 09       | 9/32                | .273 (6.9)       | .634 (16.1)  | .75 (19.1)            |
| 10       | 5/16                | .306 (7.8)       | .670 (17.0)  | .75 (19.1)            |
| 12       | 3/8                 | .359 (9.1)       | .730 (18.5)  | .88 (22.4)            |
| 14       | 7/16                | .427 (10.8)      | .791 (20.1)  | 1.00 (25.4)           |
| 16       | 1/2                 | .480 (12.2)      | .870 (22.1)  | 1.25 (31.8)           |
| 20       | 5/8                 | .603 (15.3)      | .990 (25.1)  | 1.50 (38.1)           |
| 24       | 3/4                 | .725 (18.4)      | 1.150 (29.2) | 1.75 (44.5)           |
| 28       | 7/8                 | .860 (21.8)      | 1.293 (32.8) | 1.88 (47.8)           |
| 32       | 1                   | .970 (24.6)      | 1.446 (36.7) | 2.25 (57.2)           |
| 40       | 1 1/4               | 1.205 (30.6)     | 1.759 (44.7) | 2.75 (69.9)           |
| 48       | 1 1/2               | 1.437 (36.5)     | 2.052 (52.1) | 3.25 (82.6)           |
| 56       | 1 3/4               | 1.688 (42.9)     | 2.302 (58.5) | 3.63 (92.2)           |
| 64       | 2                   | 1.937 (49.2)     | 2.552 (64.8) | 4.25 (108.0)          |

\* The minimum bend radius is based on Type A construction (see page D-3). For multiple-braided coverings, these minimum bend radii may be increased slightly.

Metric dimensions (mm) are in parentheses.

\* Consult factory for thin-wall, close convolution combination.

\*\* For PTFE maximum lengths - consult factory.

\*\*\* Consult factory for PEEK min/max dimensions.