

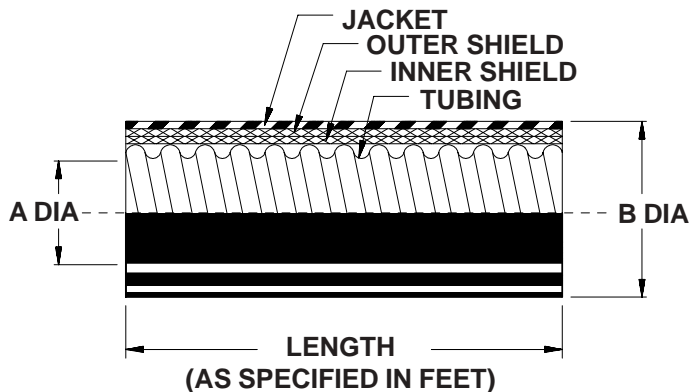

**121-103 - Type F**  
**Series 74 Helical Convuluted Tubing (MIL-T-81914) Natural or Black PFA, FEP, PTFE, Tefzel® (ETFE) or PEEK**

**TYPE F**  
**JACKET AND TWO EXTERNAL SHIELDS**



**TABLE I**

DASH NO.	FRACTIONAL SIZE REF	A INSIDE DIA MIN	B DIA MAX	MINIMUM BEND RADIUS *
06	3/16	.181 (4.6)	.540 (13.7)	.50 (12.7)
09	9/32	.273 (6.9)	.634 (16.1)	.75 (19.1)
10	5/16	.306 (7.8)	.670 (17.0)	.75 (19.1)
12	3/8	.359 (9.1)	.730 (18.5)	.88 (22.4)
14	7/16	.427 (10.8)	.791 (20.1)	1.00 (25.4)
16	1/2	.480 (12.2)	.870 (22.1)	1.25 (31.8)
20	5/8	.603 (15.3)	.990 (25.1)	1.50 (38.1)
24	3/4	.725 (18.4)	1.150 (29.2)	1.75 (44.5)
28	7/8	.860 (21.8)	1.293 (32.8)	1.88 (47.8)
32	1	.970 (24.6)	1.446 (36.7)	2.25 (57.2)
40	1 1/4	1.205 (30.6)	1.759 (44.7)	2.75 (69.9)
48	1 1/2	1.437 (36.5)	2.052 (52.1)	3.25 (82.6)
56	1 3/4	1.688 (42.9)	2.302 (58.5)	3.63 (92.2)
64	2	1.937 (49.2)	2.552 (64.8)	4.25 (108.0)

\* The minimum bend radius is based on Type A construction (see page D-3). For multiple-braided coverings, these minimum bend radii may be increased slightly.

Metric dimensions (mm) are in parentheses.

\* Consult factory for thin-wall, close convolution combination.

\*\* For PTFE maximum lengths - consult factory.

\*\*\* Consult factory for PEEK min/max dimensions.