

## GENERAL PURPOSE PLASTIC RECTIFIER

Reverse Voltage - 50 to 1000 Volts

Forward Current -1.0Ampere

### FEATURES

- The plastic package carries Underwrites Laboratory Flammability Classification 94V-0
- Construction utilizes void-free molded plastic technique
- Low reverse leakage
- High forward surge current capability
- High temperature soldering guaranteed:260°C/10 seconds at terminals  
0.375"(9.5mm) lead length, 5lbs.(2.3kg).
- Component in accordance to RoHs 2002/95/EC and WEEE 2002/96/EC

### MECHANICAL DATA

- *Case:* JEDEC DO-41 molded plastic body
- *Terminals:* Lead solderable per MIL-STD-750,method 2026
- *Polarity:* Color band denotes cathode end
- *Mounting Position:* Any
- *Weight:* 0.012ounce, 0.33 gram

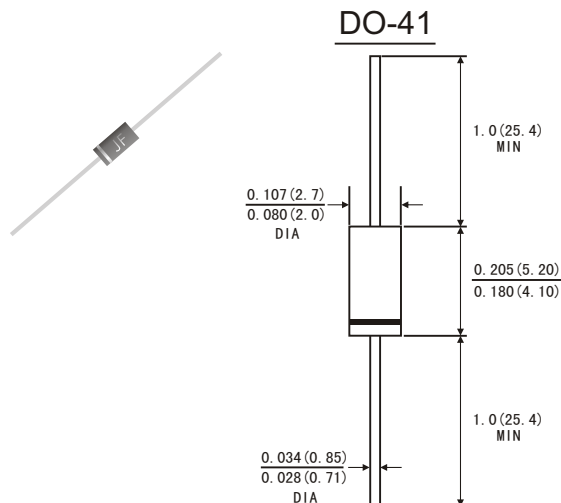

Dimensions in inches and (millimeters)

### MAXIMUM RATINGS AND ELECTRICAL CHARACTERISTICS

(Ratings at 25°C ambient temperature unless otherwise specified ,Single phase ,half wave 60Hz,,resistive or inductive load. For capacitive load, derate by 20%.)

	Symbols	1N 4001	1N 4002	1N 4003	1N 4004	1N 4005	1N 4006	1N 4007	Unis
Maximum Recurrent Peak Reverse Voltage	V <sub>RRM</sub>	50	100	200	400	600	800	1000	Volts
Maximum RMS Voltage	V <sub>RMS</sub>	35	70	140	280	420	560	700	Volts
Maximum DC Blocking Voltage	V <sub>DC</sub>	50	100	200	400	600	800	1000	Volts
Maximum average Forward Rectified Current 0.375"(9.5mm) lead length at T <sub>A</sub> =75°C	I <sub>(AV)</sub>	1.0							Amp
Peak Forward Surge Current (8.3ms half sine-wave superimposed on rated load (JEDEC method) T <sub>A</sub> =75°C	I <sub>FSM</sub>	30.0							Amps
Maximum Instantaneous Forward Voltage at 1.0 A	V <sub>F</sub>	1.0							Volts
Maximum Reverse current at rated DC Blocking Voltage	I <sub>R</sub>	5.0							μA
		50.0							
Typical Thermal resistance (Note 2)	R <sub>θJA</sub>	65.0							°C/W
Typical Junction Capacitance(Note 1)	C <sub>J</sub>	10.0							pF
Maximum DC Blocking Voltage temperature	T <sub>A</sub>	+150							°C
Operating and Storage temperature Range	T <sub>J</sub> T <sub>STG</sub>	-65 to+150							°C

**Note:** 1.Measured at 1MHz and applied reverse voltage of 4.0V DC.

2.Thermal resistance from junction to ambient and from junction to lead at 0.375"(9.5mm)lead length,  
P.C.B. mounted

# RATINGS AND CHARACTERISTIC CURVES 1N4001 THRU 1N4007

FIG.1-FORWARD CURRENT DERATING CURVE

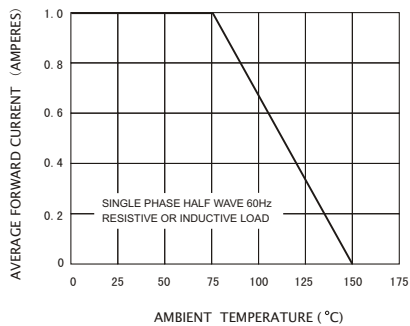

FIG.2-TYPICAL INSTANTANEOUS FORWARD CHARACTERISTICS

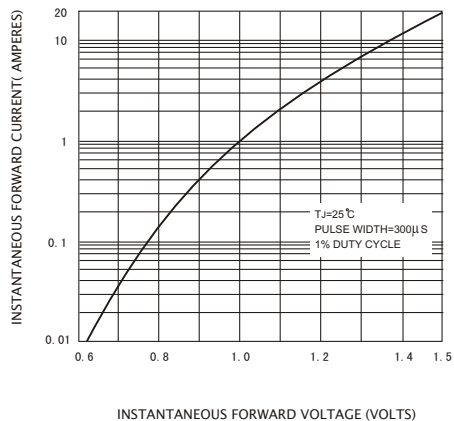

FIG.3-MAXIMUM NON-REPETITIVE PEAK FORWARD SURGE CURRENT

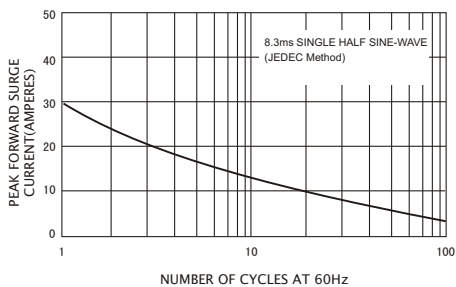

FIG.4-TYPICAL REVERSE CHARACTERISTICS

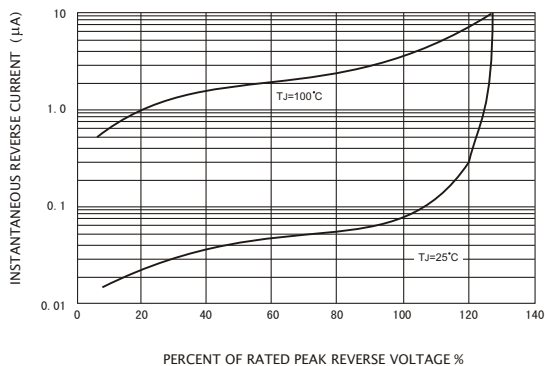

FIG.5-TYPICAL JUNCTION CAPACITANCE

