

Military Silicon Power Rectifier

1N1614–1N1616, 1N4458–1N4459

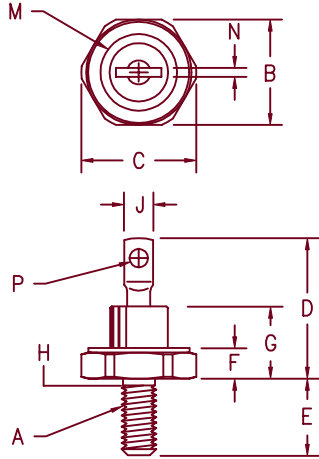

Notes:

1. 10–32 UNF3A
2. Full threads within 2 1/2 threads
3. Standard Polarity: Stud is Cathode
Reverse Polarity: Stud is Anode

Dim.	Inches		Millimeter		Notes
	Minimum	Maximum	Minimum	Maximum	
A	---	---	---	---	1
B	.424	.437	10.77	11.10	
C	---	.505	---	12.83	
D	---	.800	---	20.32	
E	.422	.453	10.72	11.51	
F	.075	.175	1.91	4.44	
G	---	.405	---	10.29	
H	.163	.189	4.15	4.80	2
J	---	.250	---	6.35	
M	---	.424	---	10.77	Dia
N	.020	.065	.510	1.65	
P	.060	---	1.52	---	Dia

D0203AA (D04)

Standard	Microsemi Catalog Number	Reverse	Peak Reverse Voltage
1N1614	1N1614R	1N1614R	200V
1N1615	1N1615R	1N1615R	400V
1N1616	1N1616R	1N1616R	600V
1N4458	1N4458R	1N4458R	800V
1N4459	1N4459R	1N4459R	1000V

- Available in JAN and JANTX quality levels
- MIL-PRF-19500/162
- Glass passivated die
- Glass to metal seal construction
- V_{RRM} – 200 to 1000 volts

Electrical Characteristics

Average forward current	$I_F(AV)$ 5 Amps	$T_C = 150^\circ C$, half sine wave, $R_{\theta JC} = 4.5^\circ C/W$
Maximum surge current	I_{FSM} 100 Amps	8.3ms, half sine, $T_C = 150^\circ C$
Max $I^2 t$ for fusing	$I^2 t$ 42 A ² s	
Max peak forward voltage	V_{FM} 1.5 Volts	$I_{FM} = 15A$: $T_J = 25^\circ C^*$
Max peak reverse voltage	I_{RM} 50 μA	$V_{RRM, T_J} = 25^\circ C$
Max peak reverse current	I_{RM} 500 μA	$V_{RRM, T_J} = 150^\circ C$
Max Recommended Operating Frequency	10kHz	

*Pulse test: Pulse width 300 μsec . Duty cycle 2%

Thermal and Mechanical Characteristics

Storage temperature range	T_{STG}	$-65^\circ C$ to $200^\circ C$
Operating case temp range	T_C	$-65^\circ C$ to $150^\circ C$
Maximum thermal resistance	$R_{\theta JC}$	4.5 $^\circ C/W$ Junction to Case
Typical thermal resistance	$R_{\theta JC}$	2.0 $^\circ C/W$ Junction to Case
Mounting torque		15 inch pounds maximum
Weight		.16 ounces (5.0 grams) typical

11–21–00 Rev. 1

1N1614-1N1616, 1N4458-1N4459

Figure 1
Typical Forward Characteristics

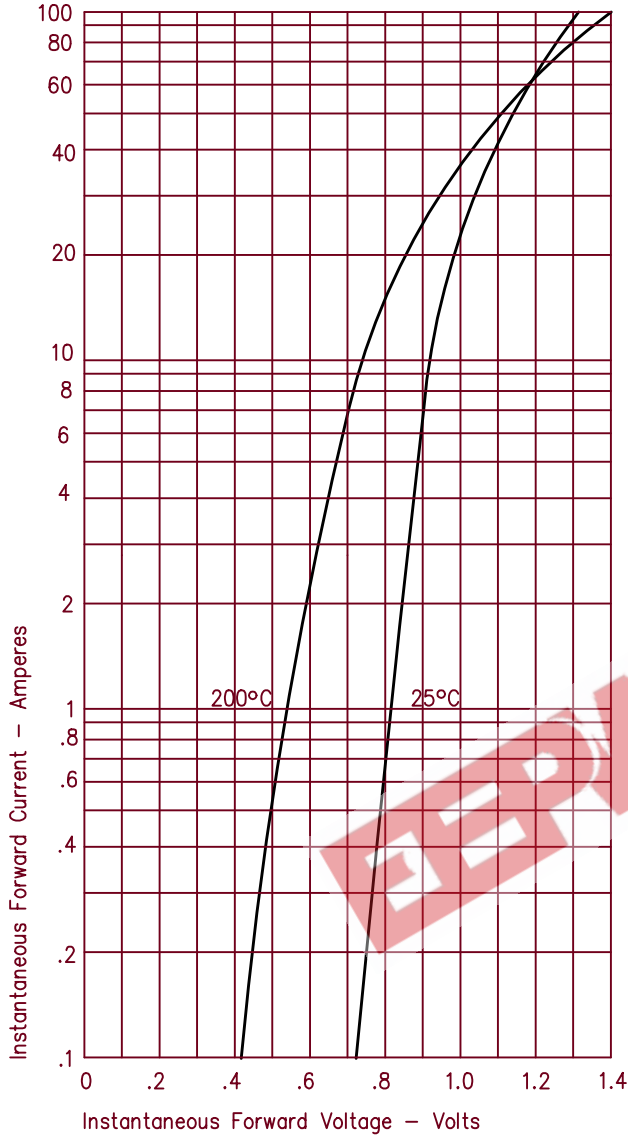

Figure 3
Forward Current Derating

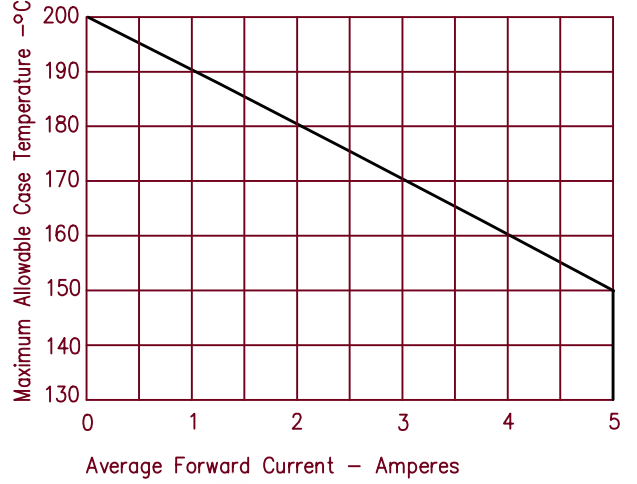

Figure 4
Transient Thermal Impedance

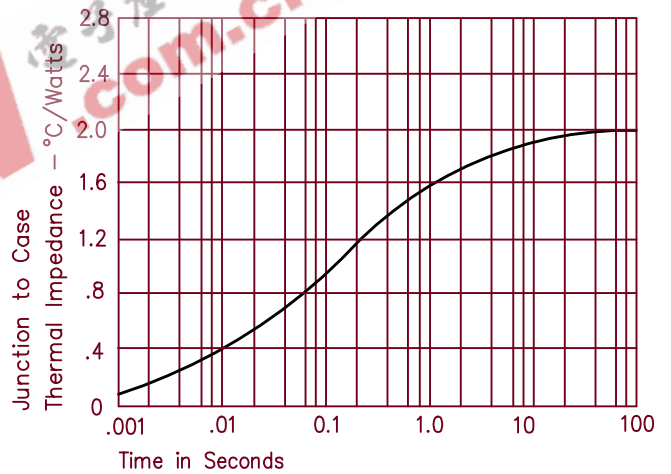

Figure 2
Typical Reverse Characteristics

