

Military Silicon Power Rectifier

1N1184–1N1190, 1N3766–1N3768

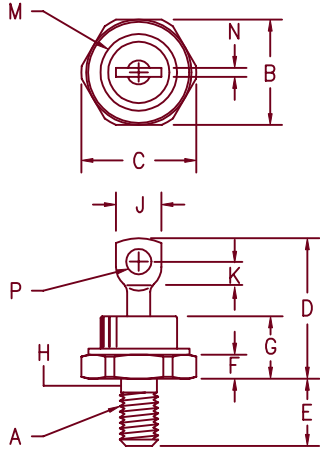

- Notes:
- 1/4–28 UNF–3A
 - Full threads within 2 1/2 threads
 - Standard Polarity: Stud is Cathode
Reverse Polarity: Stud is Anode

Dim.	Inches		Millimeter		Notes
	Minimum	Maximum	Minimum	Maximum	
A	---	---	---	---	1
B	.667	.687	16.95	17.44	
C	---	.793	---	20.14	
D	---	1.00	---	25.40	
E	.422	.453	10.72	11.50	
F	.115	.200	2.93	5.08	
G	---	.450	---	11.43	
H	.220	.249	5.59	6.32	2
J	.250	.375	6.35	9.52	
K	.156	---	3.97	---	
M	---	.667	---	16.94	Dia
N	---	.080	---	2.03	
P	.140	.175	3.56	4.44	Dia

DO203AB (D05)

- Available in JAN, JANTX, JANTXV
- MIL-PRF-19500/297
- Glass Passivated Die
- Glass to metal seal construction
- 500 Amps surge rating
- V_{RRM} to 1000V

Microsemi Catalog Number	Reverse	Peak Reverse Voltage
Standard	Reverse	
1N1184	1N1184R	100V
1N1186	1N1186R	200V
1N1188	1N1188R	400V
1N1190	1N1190R	600V
1N3766	1N3766R	800V
1N3768	1N3768R	1000V

Electrical Characteristics

Average forward current	$I_F(AV)$ 35 Amps	$T_C = 150^\circ C$, half sine wave, $R_{\theta JC} = 0.8^\circ C/W$
Maximum surge current	I_{FSM} 500 Amps	8.3ms, half sine, $T_J = 150^\circ C$
Max I^2t for fusing	I^2t 1100 A^2s	
Max peak forward voltage	V_{FM} 1.40 Volts	$I_{FM} = 110A: 25^\circ C^*$
Max peak forward voltage	V_{FM} 2.3 Volts	$I_{FM} = 500A: 25^\circ C$
Max peak reverse current	I_{RM} 10 μA	$V_{RRM}, T_J = 25^\circ C$
Max peak reverse current	I_{RM} 1.0 mA	$V_{RRM}, T_J = 150^\circ C^*$
Max Recommended Operating Frequency	10 kHz	

*Pulse test: Pulse width 300 μsec , Duty cycle 2%

Thermal and Mechanical Characteristics

Storage temp range	T_{STG}	$-65^\circ C$ to $175^\circ C$
Operating junction temp range	T_J	$-65^\circ C$ to $175^\circ C$
Max thermal resistance	$R_{\theta JC}$	$0.8^\circ C/W$ Junction to Case
Max mounting torque		30 inch pounds maximum
Typical Weight		.5 ounces (14 grams) typical

MILITARY

1N1184-1N1190, 1N3766-1N3768

Figure 1
Typical Forward Characteristics

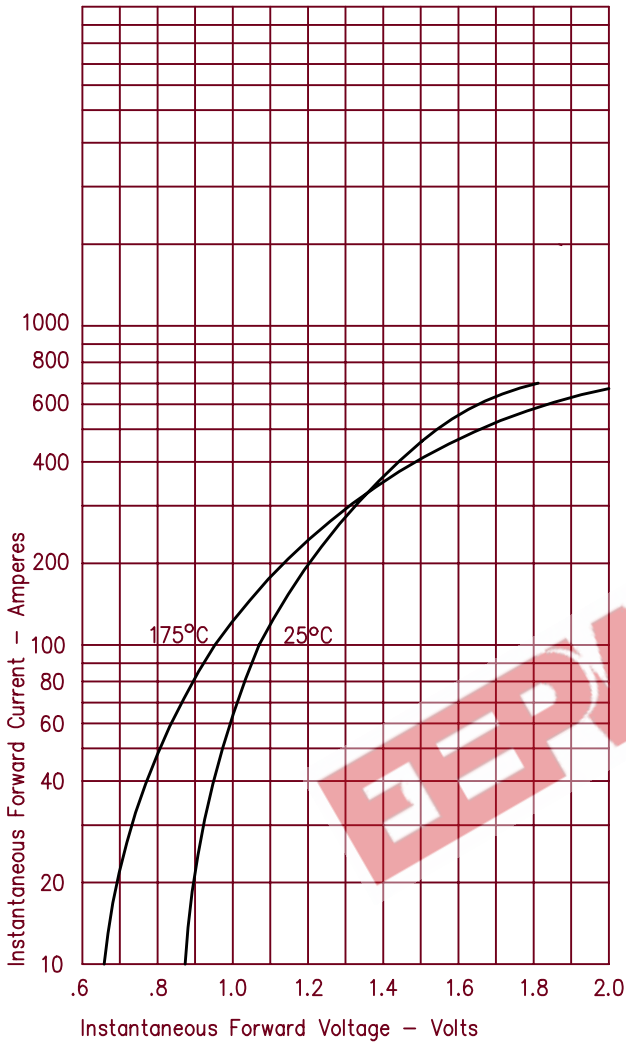

Figure 3
Forward Current Derating

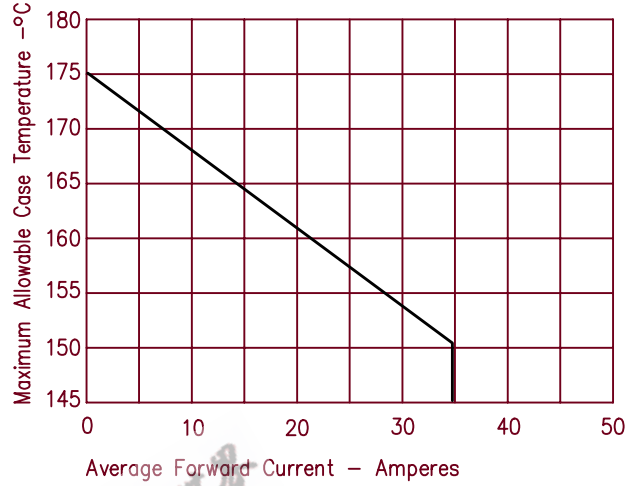

Figure 4
Transient Thermal Impedance

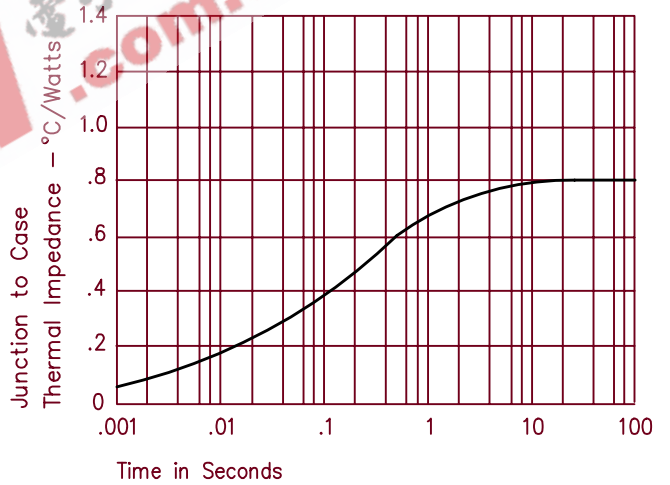

Figure 2
Typical Reverse Characteristics

