

Silicon Power Rectifier S/R304 Series

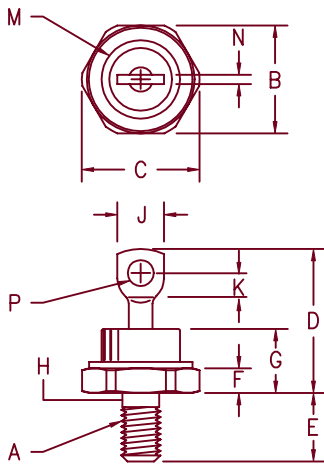

- Notes:
1. Full threads within 2 1/2 threads
 2. Standard Polarity: Stud is Cathode
Reverse Polarity: Stud is Anode

Dim.	Inches		Millimeter		Notes
	Minimum	Maximum	Minimum	Maximum	
A	---	---	---	---	1/4-28
B	.667	.687	16.95	17.44	
C	---	.793	---	20.14	
D	---	1.00	---	25.40	
E	.422	.453	10.72	11.50	
F	.115	.200	2.92	5.08	
G	---	.450	---	11.43	
H	.220	.249	5.59	6.32	1
J	.250	.375	6.35	9.52	
K	.156	---	3.97	---	
M	---	.667	---	16.94	Dia
N	---	.080	---	2.03	
P	.140	.175	3.56	4.44	Dia

D0203AB (D05)

Microsemi Catalog Number Standard	JEDEC Numbers	Peak Reverse Voltage
* S30420	SEE PAGE 2 FOR	200V
* S30440	FULL LIST OF	400V
* S30460	JEDEC NUMBERS	600V
* S30480		800V
* S304100		1000V
* S304120		1200V
* Change S to R in Part Number for Reverse Polarity		

- Glass Passivated Die
- 800A surge rating
- Glass to metal seal construction
- V_{RRM} to 1200V

Electrical Characteristics

Average forward current	IF(AV) 40 Amps	$T_C = 146^\circ\text{C}$, half sine wave, $R_{\theta JC} = 1.25^\circ\text{C/W}$ 8.3ms, half sine, $T_J = 200^\circ\text{C}$
Maximum surge current	IFSM 800 Amps	
Max I^2t for fusing	I^2t 2600 A ² s	
Max peak forward voltage	V_{FM} 1.19 Volts	$I_{FM} = 90\text{A}; T_J = 25^\circ\text{C}^*$
Max peak reverse current	I_{RM} 10 μA	$V_{RRM}, T_J = 25^\circ\text{C}$
Max peak reverse current	I_{RM} 2.0 mA	$V_{RRM}, T_J = 150^\circ\text{C}$
Max Recommended Operating Frequency	10kHz	

*Pulse test: Pulse width 300 μsec . Duty cycle 2%

Thermal and Mechanical Characteristics

Storage temperature range	T_{STG}	-65°C to 200°C
Operating junction temp range	T_J	-65°C to 200°C
Maximum thermal resistance	$R_{\theta JC}$	1.25 $^\circ\text{C/W}$ Junction to Case
Typical thermal resistance	$R_{\theta JC}$	1.1 $^\circ\text{C/W}$ Junction to Case
Mounting torque		25 - 30 inch pounds
Weight		.5 ounces (14 grams) typical

9-3-03 Rev. 3

S/R304

				JEDEC Numbers			Peak Reverse Voltage
1N1191,A	1N1301	1N1434			1N2154	1N2272	50V
1N1192,A	1N1302	1N1435			1N2155	1N2273	100V
1N1193,A				1N2021			150V
1N1194,A	1N1304	1N1436			1N2156	1N2274	200V
				1N2022			250V
1N1195,A	1N1306			1N2023	1N2157	1N2275	300V
				1N2024			350V
1N1196,A		1N1437		1N2025	1N2158	1N2276	400V
1N1197,A					1N2159	1N2277	500V
1N1198,A		1N1438			1N2160	1N2278	600V
						1N2279	800V
						1N2280	1000V
						1N2281	1200V
							Peak Reverse Voltage
	1N248,A-C			1N2793	1N3208		50V
	1N249,A-C			1N2794	1N3209		100V
				1N2795			150V
	1N250,A-C	1N2786		1N2796	1N3210	1N4525	200V
				1N2797			250V
1N2282				1N2798	1N3211		300V
				1N2799			350V
1N2283		1N2787		1N2800	1N3212	1N4526	400V
1N2284					1N3213		500V
1N2285					1N3214	1N4527	600V
1N2286						1N4528	800V
1N2287						1N4529	1000V
1N2288					1N5332	1N4530	1200V

For Reverse Polarity parts add an R suffix

S/R304

Figure 1
Typical Forward Characteristics

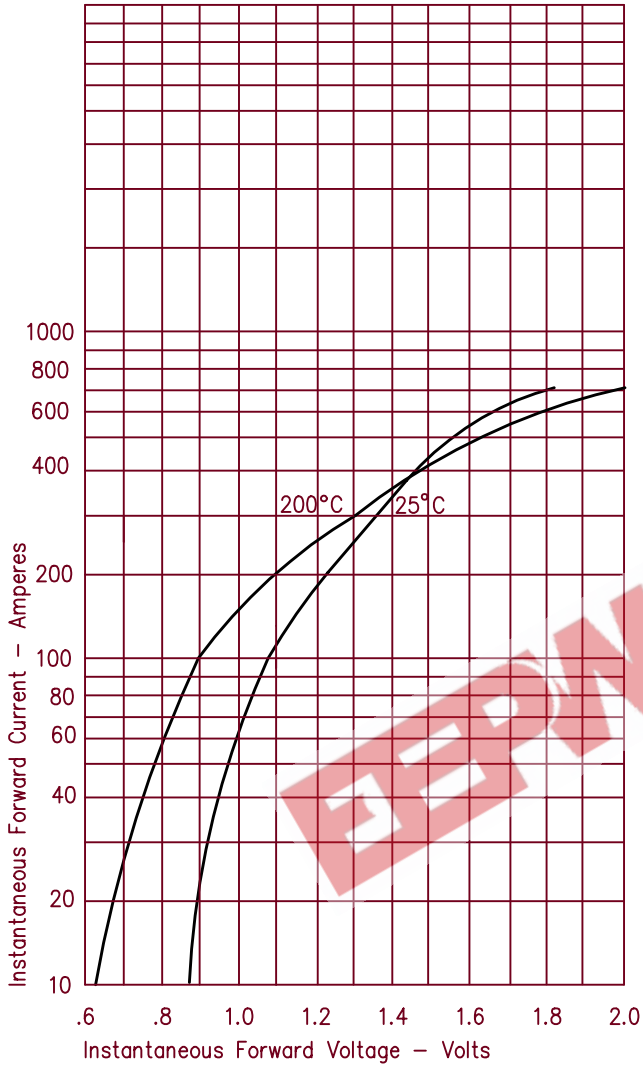

Figure 3
Forward Current Derating

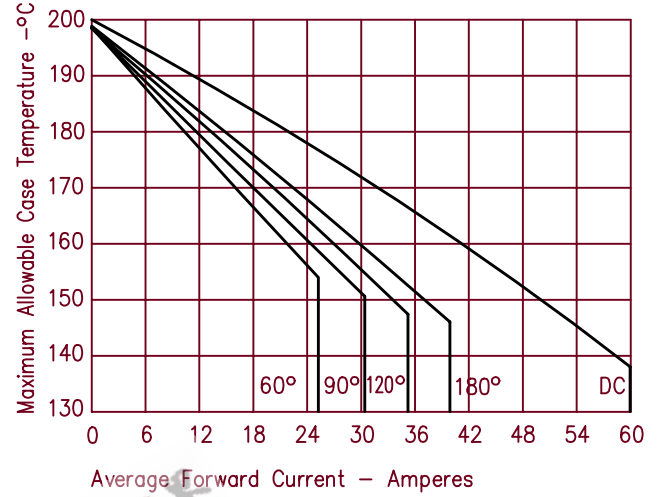

Figure 4
Maximum Forward Power Dissipation

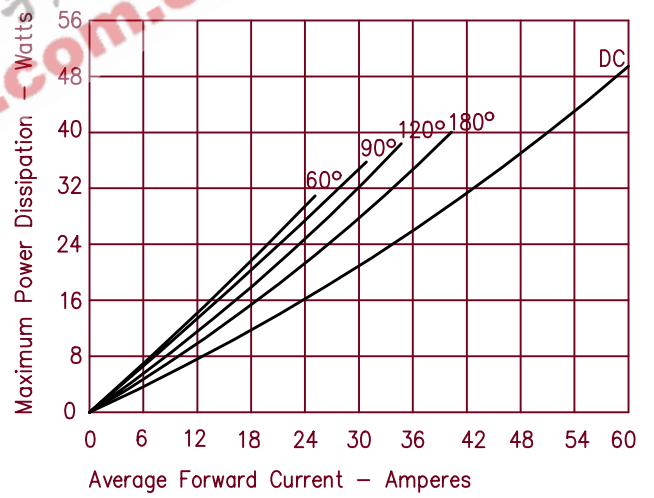

Figure 2
Typical Reverse Characteristics

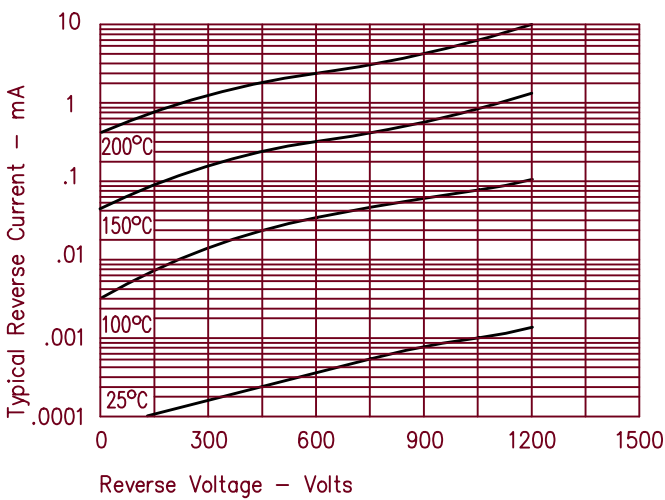

Figure 5
Transient Thermal Impedance

