

Silicon Power Rectifier

S/R35

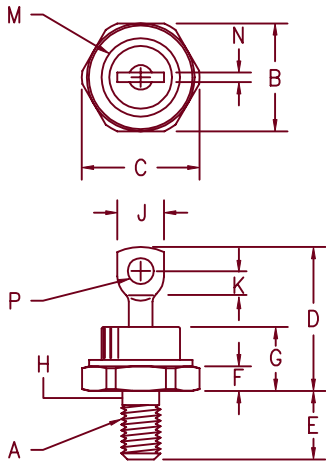

Notes:

- 1/4-28
- Full threads within 2 1/2 threads
- Standard polarity:
Stud is cathode
Reverse polarity:
Stud is anode

Dim.	Inches		Millimeter		Notes
	Minimum	Maximum	Minimum	Maximum	
A	---	---	---	---	1
B	.667	.687	16.95	17.44	
C	---	.793	---	20.14	
D	---	1.00	---	25.40	
E	.422	.453	10.72	11.50	
F	.115	.200	2.93	5.08	
G	---	.450	---	11.43	
H	.220	.249	5.59	6.32	2
J	.250	.375	6.35	9.52	
K	.156	---	3.97	---	
M	---	.667	---	16.94	Dia
N	---	.080	---	2.03	
P	.140	.175	3.56	4.44	Dia

Microsemi Catalog Number	JEDEC types	Peak Reverse Voltage
	1N2128,A 1N2458	50V
	1N2129,A 1N2459	100V
	1N2130,A 1N2460	150V
S3520	1N2131,A 1N2461 1N2788 1N3968 1N4136	200V
	1N2132,A 1N2462	250V
	1N2133,A 1N2463	300V
	1N2134,A 1N2464	350V
S3540	1N2135,A 1N2465 1N2789 1N3969 1N4137	400V
	1N2136,A 1N2466	450V
	1N2137,A 1N2467	500V
S3560	1N2138,A 1N2467 1N3970 1N4138	600V
	1N2468	700V
S3580	1N2469 1N3971	800V
S35100		1000V
S35120		1200V
S35140		1400V
S35160		1600V

For Reverse Polarity change S to R
For JEDEC parts add R suffix for Reverse Polarity

D0203AB (D05)

- Low Forward Voltage
- Glass to Metal Seal Construction
- Glass Passivated Die
- VRRM to 1600V
- 1050 Amps Surge Rating

Electrical Characteristics

Average forward current	IF(AV) 70 Amps	TC = 152°C, Half Sine Wave, RθJC = 0.65°C/W
Maximum surge current	IFSM 1050 Amps	8.3ms, half sine, TJ = 200°C
Max I ² t for fusing	I ² t 4500 A ² s	
Max peak forward voltage	VFM 1.25 Volts	IFM = 200A: TJ = 25°C*
Max peak reverse current	IRM 25 μA	VRRM, TJ = 25°C
Max peak reverse current	IRM 2.5 mA	VRRM, TJ = 150°C
Max Recommended Operating Frequency	10kHz	

*Pulse test: Pulse width 300 μsec. Duty cycle 2%

Thermal and Mechanical Characteristics

Storage temperature range	TSTG	-65°C to 200°C
Operating junction temp range	TJ	-65°C to 200°C
Maximum thermal resistance	RθJC	0.65°C/W Junction to Case
Mounting torque		25-30 inch pounds
Weight		.5 ounces (14 grams) typical

2-22-01 Rev. 2

S/R35

Figure 1
Typical Forward Characteristics

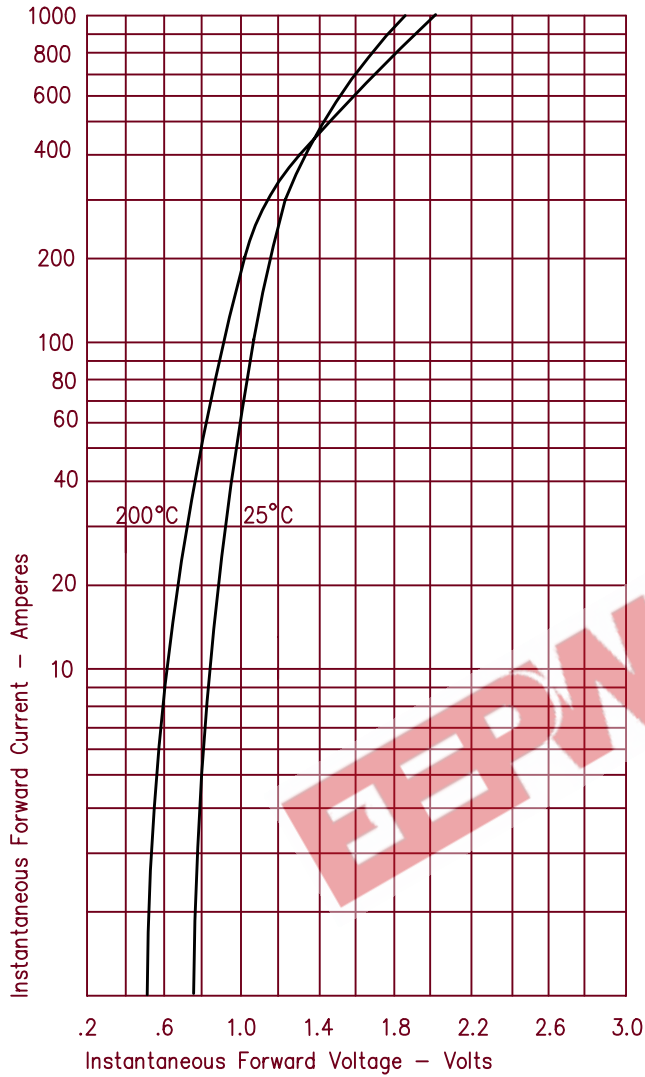

Figure 3
Forward Current Derating

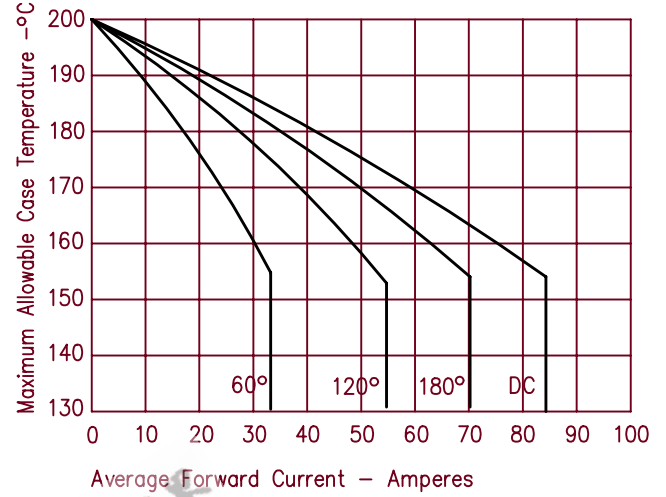

Figure 4
Maximum Forward Power Dissipation

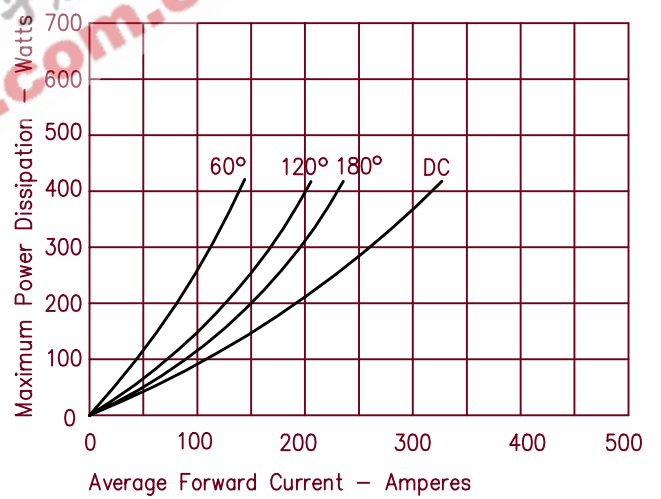

Figure 2
Typical Reverse Characteristics

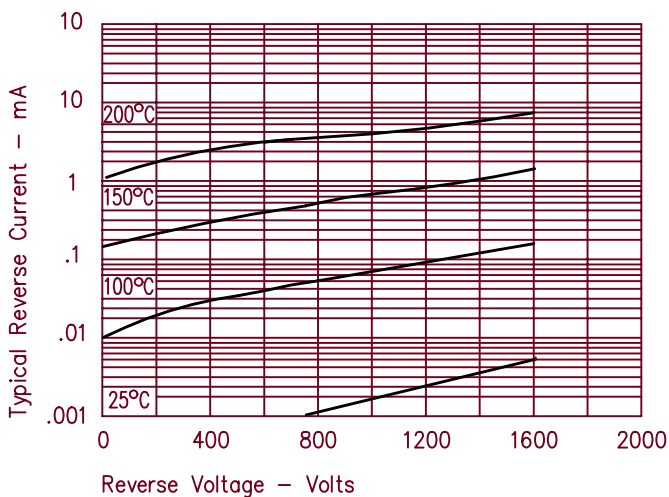

Figure 5
Transient Thermal Impedance

