

- 1N4150UR-1 AVAILABLE IN JAN, JANTX, AND JANTXV
PER MIL-PRF-19500/231
- SWITCHING DIODE
- HERMETICALLY SEALED
- METALLURGICALLY BONDED
- DOUBLE PLUG CONSTRUCTION

1N4150UR-1
1N3600UR
CDLL4150
CDLL3600

MAXIMUM RATINGS

Junction Temperature: -65°C to +175°C
Storage Temperature: -65°C to +175°C
Operating Current: 300 mA @ $T_A = +25^\circ\text{C}$
Derating: 3.1 mA dc/°C Above $T_{EC} = +110^\circ\text{C}$
Forward Surge Current: 4A, (tp = 1μs); 0.5A (tp = 1s)

ELECTRICAL CHARACTERISTICS @ 25°C, unless otherwise specified.

Type	V_{BR}	V_{RWM}	I_{R1}	I_{R2}	C	t_{rr}
	$I_R = 10 \mu\text{A}$		$V_R = 50 \text{ V dc}$ $T_A = 25^\circ\text{C}$	$V_R = 50 \text{ V dc}$ $T_A = 150^\circ\text{C}$	$V_R = 0; f = 1 \text{ Mhz};$ ac signals = 50 m V (p-p)	$I_F = I_R = 10 \text{ to } 100 \text{ mA dc}$ $R_L = 100 \text{ ohms}$
	V dc	V (pk)	μA dc	μA dc	pF	ns
CDLL3600	75	50	0.1	100	2.5	4
CDLL4150,-1	75	50	0.1	100	2.5	4

FORWARD VOLTAGE LIMITS – ALL TYPES

Limits	V_{F1}	V_{F2}	V_{F3}	V_{F4}	V_{F5}
	$I_F = 1 \text{ mA dc}$	$I_F = 10 \text{ mA dc}$	$I_F = 50 \text{ mA dc}$ (Pulsed)	$I_F = 100 \text{ mA dc}$ (Pulsed)	$I_F = 200 \text{ mA dc}$ (Pulsed)
	V dc	V dc	V dc	V dc	V dc
minimum	0.540	0.680	0.780	0.820	0.870
maximum	0.620	0.740	0.860	0.920	1.000

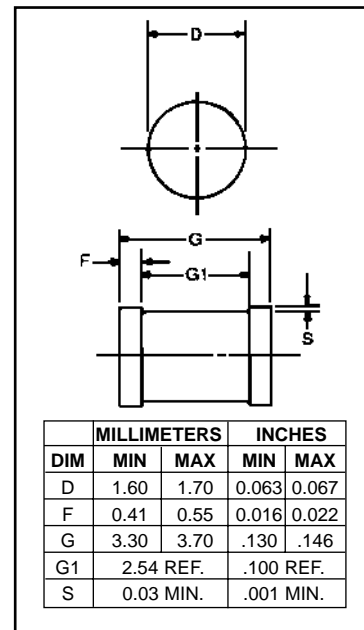

FIGURE 1

DESIGN DATA

CASE: DO-213AA, Hermetically sealed glass case. (MELF, SOD-80; LL34)

LEAD FINISH: Tin / Lead

THERMAL RESISTANCE ($R_{\theta JEC}$):
100 °C/W maximum AT L = 0

THERMAL IMPEDANCE: ($Z_{\theta JX}$): 70 °C/W maximum

POLARITY: Cathode end is banded.

MOUNTING SURFACE SELECTION:
The Axial Coefficient of Expansion (COE) of this Device is Approximately +6PPM/°C. The COE of the Mounting Surface System Should Be Selected To Provide A Suitable Match With This Device.



COMPENSATED DEVICES INCORPORATED

22 COREY STREET, MELROSE, MASSACHUSETTS 02176
PHONE (781) 665-1071 FAX (781) 665-7379
WEBSITE: <http://www.cdi-diodes.com> E-mail: mail@cdi-diodes.com

IN4150UR-1, IN3600UR-1, CDLL4150 and CDLL3600

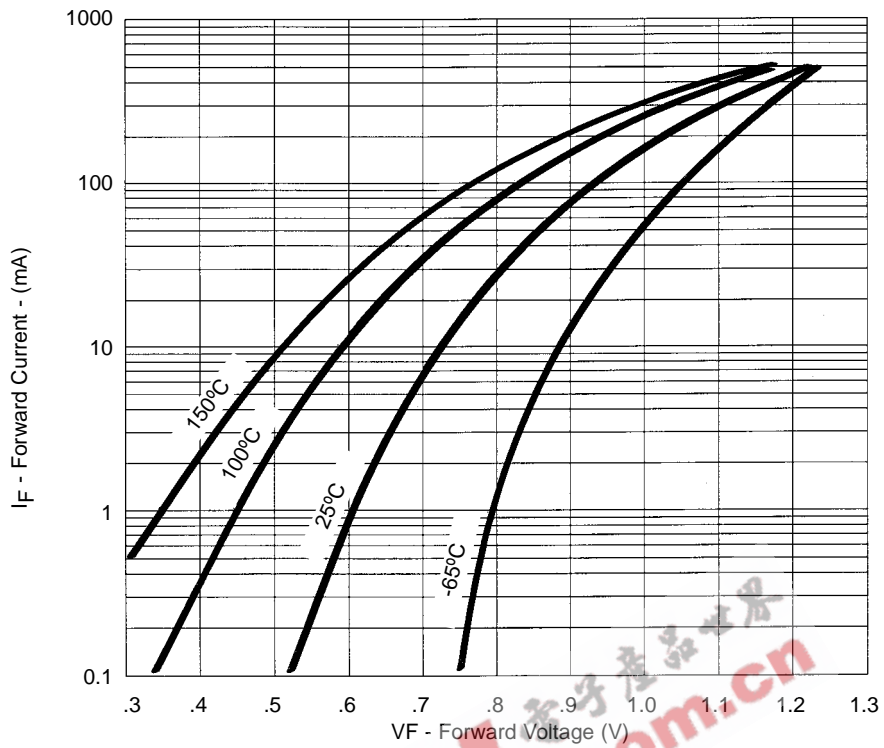
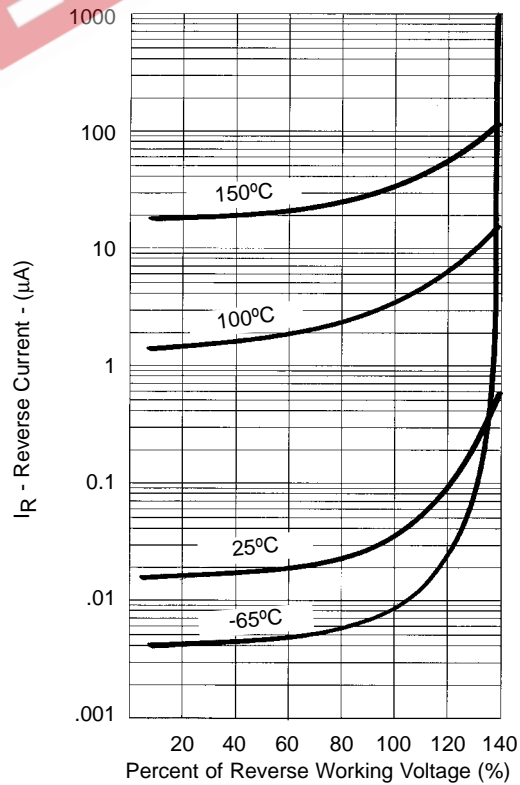

FIGURE 2
Typical Forward Current
vs Forward Voltage



NOTE : All temperatures shown on graphs are junction temperatures

FIGURE 3
Typical Reverse Current
vs Reverse Voltage