

DATA SHEET

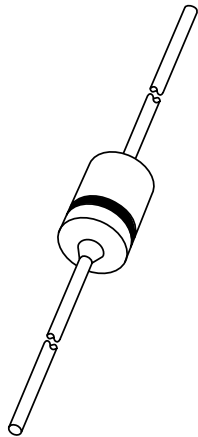

EEPW 电子产品世界
.com.cn

1N5225B to 1N5267B Voltage regulator diodes

Product specification
Supersedes data of April 1992

1996 Apr 26

Voltage regulator diodes

1N5225B to 1N5267B

FEATURES

- Total power dissipation: max. 500 mW
- Tolerance series: $\pm 5\%$
- Working voltage range: nom. 3.0 to 75 V
- Non-repetitive peak reverse power dissipation: max. 40 W.

APPLICATIONS

- Low-power voltage stabilizers or voltage references.

DESCRIPTION

Low-power voltage regulator diodes in hermetically sealed leaded glass SOD27 (DO-35) packages.

The series consists of 43 types with nominal working voltages from 3.0 to 75 V.

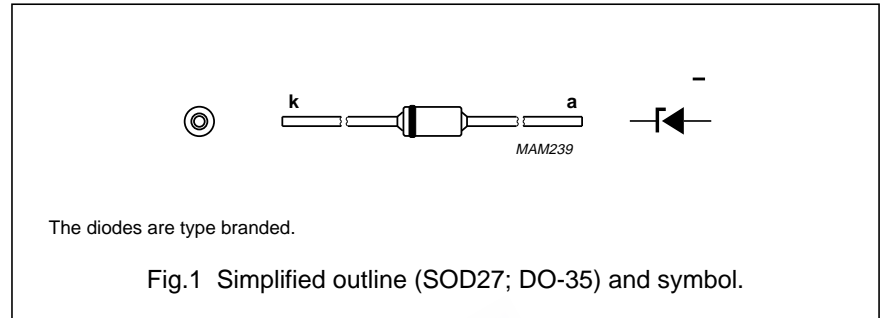

LIMITING VALUES

In accordance with the Absolute Maximum Rating System (IEC 134).

SYMBOL	PARAMETER	CONDITIONS	MIN.	MAX.	UNIT
I_F	continuous forward current		–	250	mA
I_{ZSM}	non-repetitive peak reverse current	$t_p = 100 \mu s$; square wave; $T_j = 25 \text{ }^\circ\text{C}$ prior to surge	see Table "Per type"		
P_{tot}	total power dissipation	$T_{amb} = 50 \text{ }^\circ\text{C}$; lead length max.; note 1	–	400	mW
		Lead length 8 mm; note 2	–	500	mW
P_{ZSM}	non-repetitive peak reverse power dissipation	$t_p = 100 \mu s$; square wave; $T_j = 25 \text{ }^\circ\text{C}$ prior to surge; see Fig.3	–	40	W
		$t_p = 8.3 \text{ ms}$; square wave; $T_j \leq 55 \text{ }^\circ\text{C}$ prior to surge	–	10	W
T_{stg}	storage temperature		–65	+200	$^\circ\text{C}$
T_j	junction temperature		–65	+200	$^\circ\text{C}$

Notes

1. Device mounted on a printed circuit-board without metallization pad.
2. Tie-point temperature $\leq 75 \text{ }^\circ\text{C}$.

ELECTRICAL CHARACTERISTICS

Table 1

$T_j = 25 \text{ }^\circ\text{C}$; unless otherwise specified.

SYMBOL	PARAMETER	CONDITIONS	MAX.	UNIT
V_F	forward voltage	$I_F = 200 \text{ mA}$; see Fig.4	1.1	V

Voltage regulator diodes

1N5225B to 1N5267B

Per type

$T_j = 25\text{ }^\circ\text{C}$; unless otherwise specified.

TYPE No.	WORKING VOLTAGE V_Z (V) ⁽¹⁾ at I_{Ztest}	DIFFERENTIAL RESISTANCE r_{dif} (Ω) at I_{Ztest}	TEMP. COEFF. S_Z (%/K) at $I_Z^{(2)}$	TEST CURRENT I_{Ztest} (mA)	DIODE CAP. C_d (pF) at $f = 1\text{ MHz}$; at $V_R = 0\text{ V}$	REVERSE CURRENT at REVERSE VOLTAGE		NON-REPETITIVE PEAK REVERSE CURRENT I_{ZSM} (A) $t_p = 100\text{ }\mu\text{s}$; $T_{amb} = 25\text{ }^\circ\text{C}$
	NOM.	MAX.	MAX.		MAX.	I_R (μA)	V_R (V)	MAX.
1N5225B	3.0	1600	-0.075	20	450	50	1.0	6.0
1N5226B	3.3	1600	-0.070	20	450	25	1.0	6.0
1N5227B	3.6	1700	-0.065	20	450	15	1.0	6.0
1N5228B	3.9	1900	-0.060	20	450	10	1.0	6.0
1N5229B	4.3	2000	± 0.055	20	450	5	1.0	6.0
1N5230B	4.7	1900	± 0.030	20	450	5	1.5	6.0
1N5231B	5.1	1600	± 0.030	20	300	5	2.0	6.0
1N5232B	5.6	1600	+0.038	20	300	5	3.0	6.0
1N5233B	6.0	1600	+0.038	20	300	5	3.5	6.0
1N5234B	6.2	1000	+0.045	20	200	5	4.0	6.0
1N5235B	6.8	750	+0.050	20	200	3	5.0	6.0
1N5236B	7.5	500	+0.058	20	150	3	6.0	4.0
1N5237B	8.2	500	+0.062	20	150	3	6.5	4.0
1N5238B	8.7	600	+0.065	20	150	3	6.5	3.5
1N5239B	9.1	600	+0.068	20	150	3	7.0	3.0
1N5240B	10	600	+0.075	20	90	3	8.0	3.0
1N5241B	11	600	+0.076	20	85	2	8.4	2.5
1N5242B	12	600	+0.077	20	85	1	9.1	2.5
1N5243B	13	600	+0.079	9.5	80	0.5	9.9	2.5
1N5244B	14	600	+0.082	9.0	80	0.1	10.0	2.0
1N5245B	15	600	+0.082	8.5	75	0.1	11.0	2.0
1N5246B	16	600	+0.083	7.8	75	0.1	12.0	1.5
1N5247B	17	600	+0.084	7.4	75	0.1	13.0	1.5
1N5248B	18	600	+0.085	7.0	70	0.1	14.0	1.5
1N5249B	19	600	+0.086	6.6	70	0.1	14.0	1.5
1N5250B	20	600	+0.086	6.2	60	0.1	15.0	1.5

Voltage regulator diodes

1N5225B to 1N5267B

TYPE No.	WORKING VOLTAGE V_Z (V) ⁽¹⁾ at I_{Ztest}	DIFFERENTIAL RESISTANCE r_{dif} (Ω) at I_{Ztest}	TEMP. COEFF. S_z (%/K) at $I_z^{(2)}$	TEST CURRENT I_{Ztest} (mA)	DIODE CAP. C_d (pF) at $f = 1$ MHz; at $V_R = 0$ V	REVERSE CURRENT at REVERSE VOLTAGE		NON-REPETITIVE PEAK REVERSE CURRENT I_{ZSM} (A) $t_p = 100 \mu s$; $T_{amb} = 25^\circ C$
	NOM.	MAX.	MAX.		MAX.	I_R (μA)	V_R (V)	MAX.
1N5251B	22	600	+0.087	5.6	60	0.1	17.0	1.25
1N5252B	24	600	+0.088	5.2	55	0.1	18.0	1.25
1N5253B	25	600	+0.089	5.0	55	0.1	19.0	1.25
1N5254B	27	600	+0.090	4.6	50	0.1	21.0	1.0
1N5255B	28	600	+0.091	4.5	50	0.1	21.0	1.0
1N5256B	30	600	+0.091	4.2	50	0.1	23.0	1.0
1N5257B	33	700	+0.092	3.8	45	0.1	25.0	0.9
1N5258B	36	700	+0.093	3.4	45	0.1	27.0	0.8
1N5259B	39	800	+0.094	3.2	45	0.1	30.0	0.7
1N5260B	43	900	+0.095	3.0	40	0.1	33.0	0.6
1N5261B	47	1000	+0.095	2.7	40	0.1	36.0	0.5
1N5262B	51	1100	+0.096	2.5	40	0.1	39.0	0.4
1N5263B	56	1300	+0.096	2.2	40	0.1	43.0	0.3
1N5264B	60	1400	+0.097	2.1	40	0.1	46.0	0.3
1N5265B	62	1400	+0.097	2.0	35	0.1	47.0	0.3
1N5266B	68	1600	+0.097	1.8	35	0.1	52.0	0.25
1N5267B	75	1700	+0.098	1.7	35	0.1	56.0	0.2

Notes

- V_Z is measured with device at thermal equilibrium while held in clips at 10 mm from body in still air at 25 °C.
- For types 1N5225B to 1N5242B the I_z current is 7.5 mA; for 1N5243B and higher $I_z = I_{Ztest}$. S_z values valid between 25 °C and 125 °C.

Voltage regulator diodes

1N5225B to 1N5267B

THERMAL CHARACTERISTICS

SYMBOL	PARAMETER	CONDITIONS	VALUE	UNIT
$R_{th\ j-tp}$	thermal resistance from junction to tie-point	lead length 10 mm	300	K/W
$R_{th\ j-a}$	thermal resistance from junction to ambient	lead length max.; see Fig.2 and note 1	380	K/W

Note

1. Device mounted on a printed circuit-board without metallization pad.

EEPW 电子产品世界
.com.cn

Voltage regulator diodes

1N5225B to 1N5267B

GRAPHICAL DATA

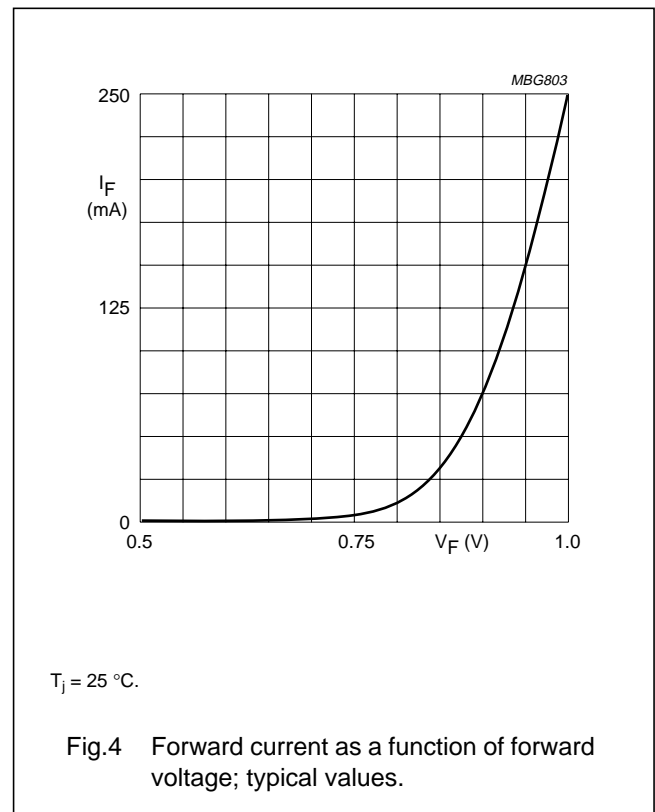
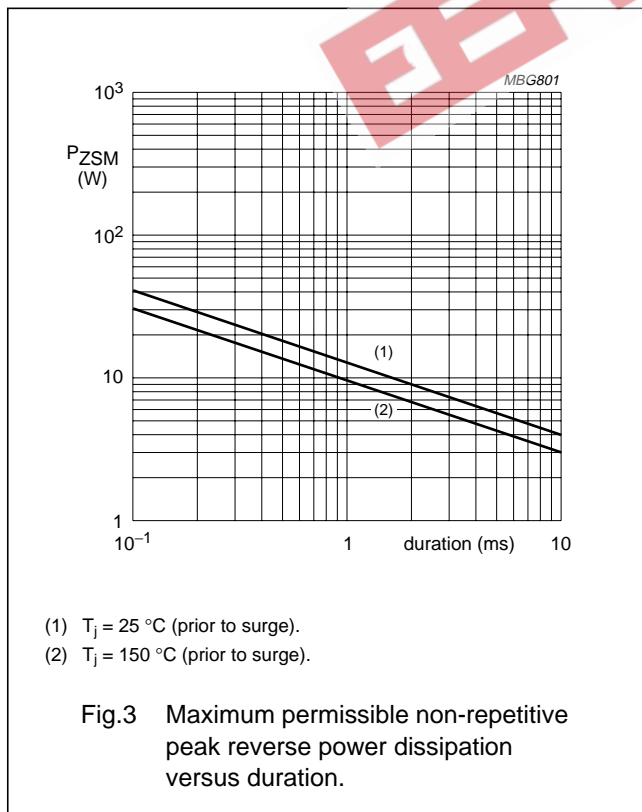
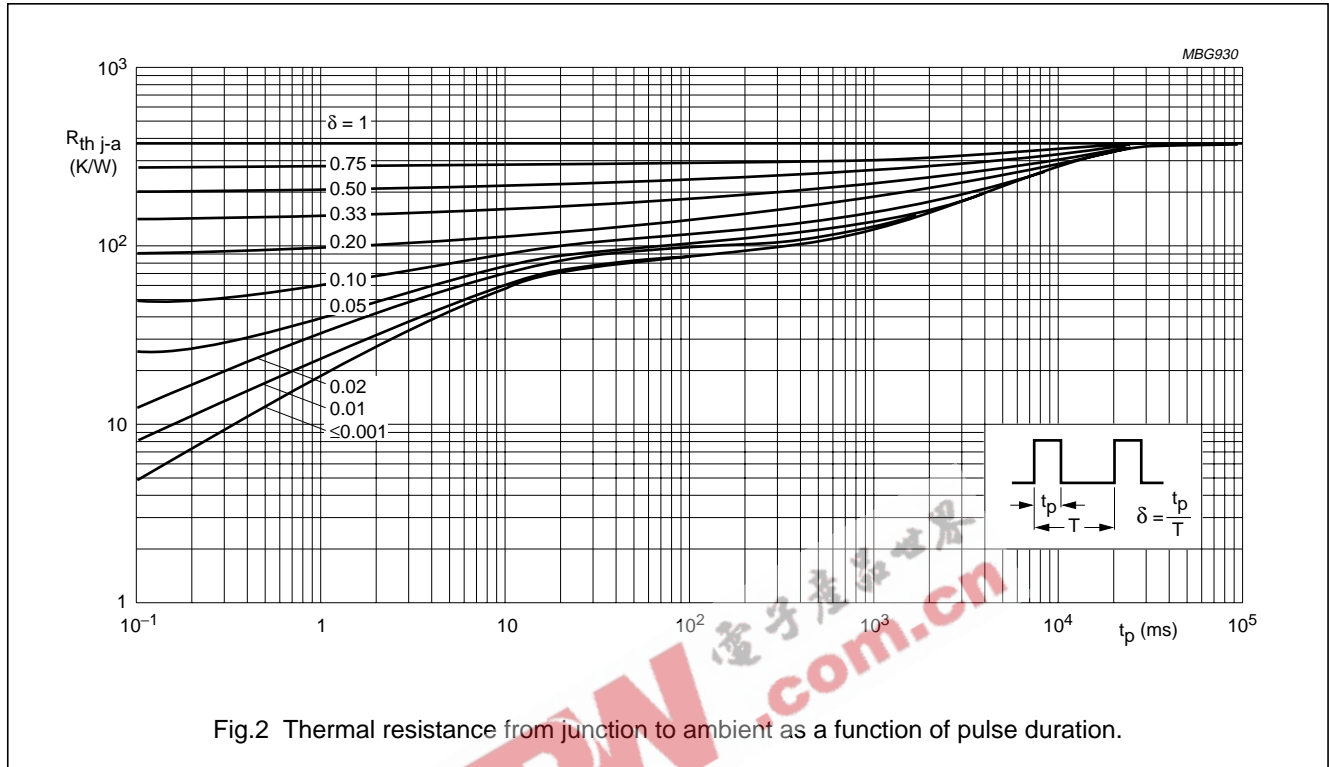

Voltage regulator diodes

1N5225B to 1N5267B

PACKAGE OUTLINE

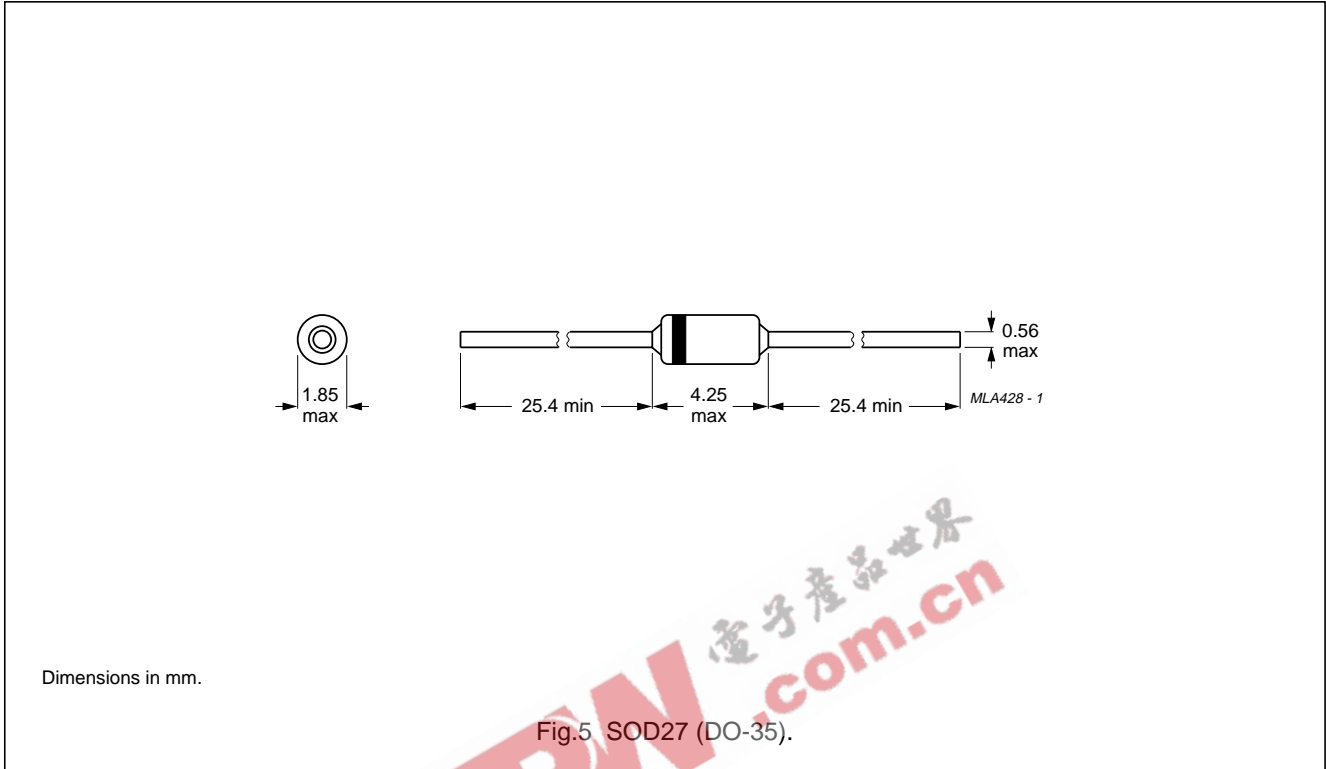

DEFINITIONS

Data sheet status	
Objective specification	This data sheet contains target or goal specifications for product development.
Preliminary specification	This data sheet contains preliminary data; supplementary data may be published later.
Product specification	This data sheet contains final product specifications.
Limiting values	
Limiting values given are in accordance with the Absolute Maximum Rating System (IEC 134). Stress above one or more of the limiting values may cause permanent damage to the device. These are stress ratings only and operation of the device at these or at any other conditions above those given in the Characteristics sections of the specification is not implied. Exposure to limiting values for extended periods may affect device reliability.	
Application information	
Where application information is given, it is advisory and does not form part of the specification.	

LIFE SUPPORT APPLICATIONS

These products are not designed for use in life support appliances, devices, or systems where malfunction of these products can reasonably be expected to result in personal injury. Philips customers using or selling these products for use in such applications do so at their own risk and agree to fully indemnify Philips for any damages resulting from such improper use or sale.