

DESCRIPTION

This surface mount Zener Voltage Regulator series is military qualified to MIL-PRF-19500/356 and is ideal for high-reliability applications where a failure cannot be tolerated. These industry-recognized 5 Watt Zener Voltage Regulators are hermetically sealed with voidless-glass construction using an internal metallurgical bond. It includes Zener selections from 3.3 to 390 volts in standard 5% tolerances as well as tighter tolerances identified by different suffix letters on the part number. They are also available in axial-leaded packages for thru hole mounting by deleting the "US" suffix (see separate data sheet for 1N4954 thru 1N4996, 1N5968 thru 1N5969, and 1N6632 thru 1N6637). Microsemi also offers numerous other Zener products to meet higher and lower power ratings in both thru-hole and surface mount packages.

IMPORTANT: For the most current data, consult MICROSEMI's website: <http://www.microsemi.com>

APPEARANCE

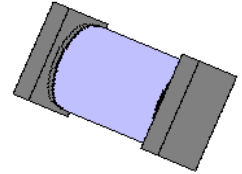

**"E" Package
(or "D-5B")**

FEATURES

- Popular JEDEC registered series
- Voidless hermetically sealed glass package
- Triple-layer passivation
- Internal "Category I" Metallurgical bonds for 1N4954US thru 1N4996US, and "Category III" for 1N6632US thru 1N6637US as well as 1N5968US thru 1N5969US
- JAN, JANTX, JANTXV, and JANS available per MIL-PRF-19500/356
- Axial-leaded equivalents (see separate data sheet for 1N4954 thru 1N4996, 1N6632 thru 1N6637 and 1N5968 thru 1N5969)

APPLICATIONS / BENEFITS

- Regulates voltage over a broad operating current and temperature range
- Extensive selection from 3.3 to 390 V
- Standard voltage tolerances are plus/minus 5% with no suffix
- Tight tolerances available in plus or minus 2% or 1% with C or D suffix respectively
- Extremely robust construction
- Nonsensitive to ESD per MIL-STD-750 Method 1020
- Inherently radiation hard as described in Microsemi MicroNote 050

MAXIMUM RATINGS

- Operating Temperature: -65°C to +175°C.
- Storage Temperature: -65°C to +175°C.
- Power Dissipation: 5 Watts @ $T_{EC} = 125^{\circ}C$ and derate linearly at 0.1 W/°C above $T_{EC} = 125^{\circ}C$ to zero at 175°C
- Thermal Resistance: 7°C/W junction to end cap for 1N4954US thru 1N4996US and 10°C/W for 1N6632US thru 1N6637US as well as 1N5968US thru 1N5969US
- Thermal Impedance at 10 ms: 1.8°C/W for 1N4954US thru 1N4996US, and 3.0°C/W for both the 1N6632US thru 1N6637US & 1N5968US thru 1N5969US
- Forward Voltage: 1.50 V at 1.0 A

MECHANICAL AND PACKAGING

- CASE: Hermetically sealed voidless hard glass with Tungsten slugs
- TERMINATIONS: End caps are solid Silver (Ag) with Tin/Lead (Sn/Pb) finish
- MARKING: None
- POLARITY: Cathode indicated by band
- Tape & Reel option: Standard per EIA-481-B
- Weight: 539 mg



1N4954US thru 1N4996US, 1N5968US thru 1N5969US, and 1N6632US thru 1N6637US

VOIDLESS-HERMETICALLY-SEALED
Surface Mount 5 WATT GLASS ZENER

www.Microsemi.com



1N4954US thru 1N4996US
1N5968US thru 1N5969US
1N6632US thru 1N6637US

ELECTRICAL CHARACTERISTICS @ 25°C

TYPE*	NOMINAL ZENER VOLTAGE $V_Z @ I_{ZT}$	TEST CURRENT I_{ZT}	MAXIMUM DYNAMIC IMPEDANCE		VOLTAGE REGULATION (Note 1) ΔV_Z	MAXIMUM REVERSE LEAKAGE CURRENT VOLTAGE		MAXIMUM TEMPERATURE COEFF. $\alpha_{VZ} @ I_{ZT}$	MAXIMUM CONTINUOUS CURRENT I_{ZM}	SURGE CURRENT I_{ZSM}
			$Z_z @ I_{ZT}$	$Z_{zk}^* @ I_{ZK}=1mA$		I_R	V_R			
			OHMS	OHMS		μA	VOLTS			
1N6632US	3.3	380	3.0	500	0.90	300	1.0	-.075	1440	20.0
1N6633US	3.6	350	2.5	500	0.80	250	1.0	-.070	1320	18.7
1N6634US	3.9	320	2.0	500	0.75	175	1.0	-.060	1220	17.6
1N6635US	4.3	290	2.0	500	0.70	25	1.0	-.050	1100	16.4
1N6636US	4.7	260	2.0	450	0.60	20	1.0	+/- .025	1010	15.3
1N6637US	5.1	240	1.5	400	0.50	5	1.0	+/- .030	930	14.4
1N5968US	5.6	220	1.0	400	0.4	5000	4.28	.04	865	20
1N5969US	6.2	220	1.0	1000	0.5	1000	4.74	.04	765	20
1N4954US	6.8	175	1.0	1000	0.7	150	5.2	.05	700	29.3
1N4955US	7.5	175	1.5	800	0.7	100	5.7	.06	630	26.4
1N4956US	8.2	150	1.5	600	0.7	50	6.2	.06	580	24
1N4957US	9.1	150	2.0	400	0.7	25	6.9	.06	520	22
1N4958US	10.0	125	2.0	125	0.8	25	7.6	.07	475	20
1N4959US	11	125	2.5	130	0.8	10	8.4	.07	430	19
1N4960US	12	100	2.5	140	0.8	10	9.1	.07	395	18
1N4961US	13	100	3.0	145	0.9	10	9.9	.08	365	16
1N4962US	15	75	3.5	150	1.0	5	11.4	.08	315	12
1N4963US	16	75	3.5	155	1.1	5	12.2	.08	294	10
1N4964US	18	65	4.0	160	1.2	5	13.7	.085	264	9.0
1N4965US	20	65	4.5	165	1.5	2	15.2	.085	237	8.0
1N4966US	22	50	5.0	170	1.8	2	16.7	.085	216	7.0
1N4967US	24	50	5.0	175	2.0	2	18.2	.090	198	6.5
1N4968US	27	50	6.0	180	2.0	2	20.6	.090	176	6.0
1N4969US	30	40	8	190	2.5	2	22.8	.090	158	5.5
1N4970US	33	40	10	200	2.8	2	25.1	.095	144	5.0
1N4971US	36	30	11	220	3.0	2	27.4	.095	132	4.5
1N4972US	39	30	14	230	3.0	2	29.7	.095	122	4.0
1N4973US	43	30	20	240	3.3	2	32.7	.095	110	3.5
1N4974US	47	25	25	250	3.5	2	35.8	.095	100	3.2
1N4975US	51	25	27	270	4.0	2	38.8	.095	92	3.0
1N4976US	56	20	35	320	4.4	2	42.6	.095	84	2.8
1N4977US	62	20	42	400	5.0	2	47.1	.100	76	2.5
1N4978US	68	20	50	500	5.5	2	51.7	.100	70	2.2
1N4979US	75	20	55	620	6.0	2	56.0	.100	63.0	2.0
1N4980US	82	15	80	720	6.6	2	62.2	.100	58.0	1.8
1N4981US	91	15	90	760	7.5	2	69.2	.100	52.5	1.6
1N4982US	100	12	110	800	8.0	2	76.0	.100	47.5	1.4
1N4983US	110	12	125	1000	9.0	2	83.6	.100	43.0	1.2
1N4984US	120	10	170	1150	10	2	91.2	.100	39.5	1.00
1N4985US	130	10	190	1250	11	2	98.8	.105	36.6	0.80
1N4986US	150	8	330	1500	13	2	114.0	.105	31.6	0.75
1N4987US	160	8	350	1650	14	2	121.6	.105	29.4	0.70
1N4988US	180	5	450	1750	16	2	136.8	.110	26.4	0.60
1N4989US	200	5	500	1850	18	2	152	.110	23.6	0.50
1N4990US	220	5	550	2000	19	2	167	.115	21.6	0.50
1N4991US	240	5	650	2050	22	2	182	.115	19.8	0.40
1N4992US	270	5	800	2100	25	2	206	.120	17.5	0.35
1N4993US	300	4	950	2150	28	2	228	.120	15.6	0.30
1N4994US	330	4	1175	2200	32	2	251	.120	14.4	0.25
1N4995US	360	3	1400	2300	35	2	274	.120	13.0	0.22
1N4996US	390	3	1800	2500	40	2	297	.120	12.0	0.20

* $I_{ZK} = 5$ mA for 1N5968

NOTE 1: Maximum voltage change ΔV_Z between 10% of I_{ZM} and 50% of I_{ZM}

SYMBOLS & DEFINITIONS

Symbol	Definition
V_Z	Zener Voltage: The zener voltage the device will exhibit at a specified current (I_Z) in its breakdown region.
I_Z, I_{ZT}, I_{ZK}	Regulator Current: The dc regulator current (I_Z), at a specified test point (I_{ZT}), or near breakdown knee (I_{ZK}).
Z_{ZT} or Z_{ZK}	Dynamic Impedance: The small signal impedance of the diode when biased to operate in its breakdown region at a specified rms current modulation (typically 10% of I_{ZT} or I_{ZK}) and superimposed on I_{ZT} or I_{ZK} respectively.
V_F	Maximum Forward Voltage: The maximum forward voltage the device will exhibit at a specified current.
I_R	Maximum Reverse Current: The maximum reverse (leakage) current that will flow at the specified voltage and temperature.
I_{ZM}	Maximum Regulator (Zener) Current: The maximum rated dc current for the specified power rating.
I_{ZSM}	Maximum Zener Surge Current: The nonrepetitive peak value of zener surge current at a specified wave form.

GRAPHS

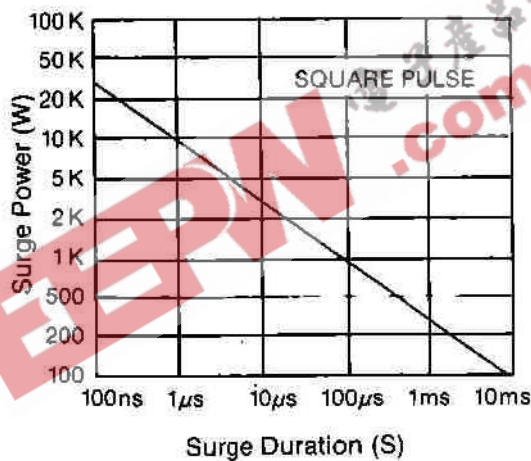

FIGURE 1
SURGE POWER vs.
SURGE DURATION

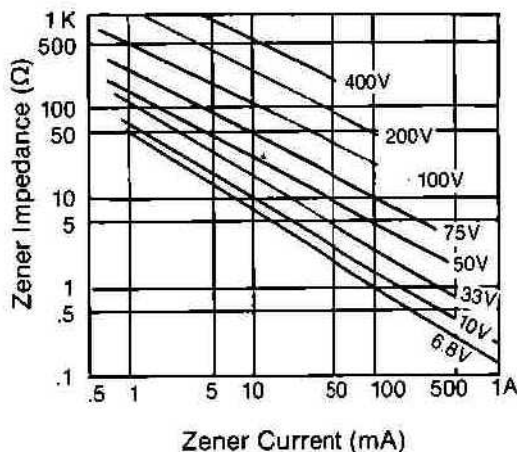
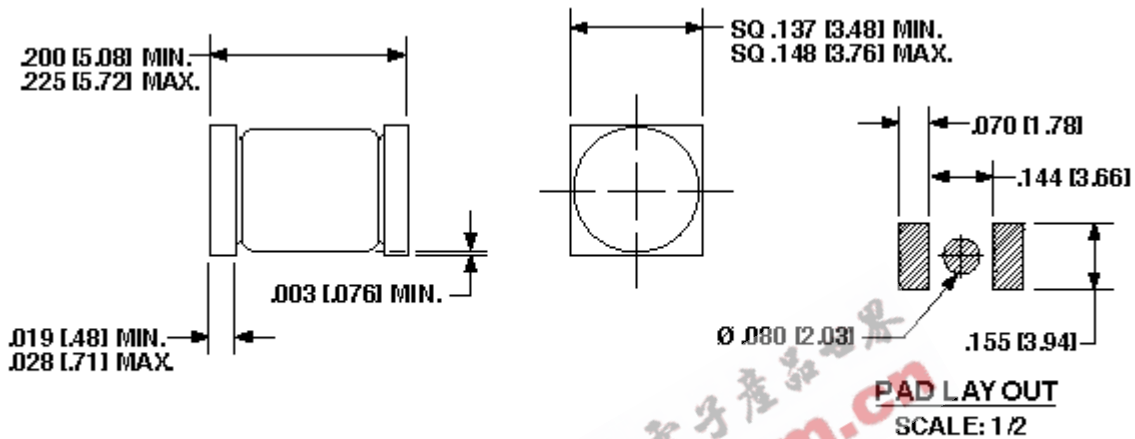

FIGURE 2
TYPICAL ZENER IMPEDANCE vs.
ZENER CURRENT

PACKAGE DIMENSIONS AND PAD LAYOUT



NOTE: DIMENSIONS IN INCHES [MM]

This Package Outline has also previously
been identified as "D-5B"

Note: If mounting requires adhesive separate from the solder,
an additional 0.080 inch diameter contact may be placed in the
center between the pads as an optional spot for cement as
shown in the pad layout.