

1N6818
(MSASC75H45F)

1N6818R
(MSASC75H45FR)

45 Volts
75 Amps

LOW VOLTAGE
DROP SCHOTTKY
DIODE

Features

- Tungsten/Platinum schottky barrier for very low VF
- Oxide passivated structure for very low leakage currents
- Guard ring protection for increased reverse energy capability
- Epitaxial structure minimizes forward voltage drop
- Hermetically sealed, low profile ceramic surface mount power package
- Low package inductance
- Very low thermal resistance
- Available as standard polarity (strap is anode: 1N6818) and reverse polarity (strap is cathode: 1N6818R)

Maximum Ratings @ 25°C (unless otherwise specified)

DESCRIPTION	SYMBOL	MAX.	UNIT	
Peak Repetitive Reverse Voltage	V_{RRM}	45	Volts	
Working Peak Reverse Voltage	V_{RWM}	45	Volts	
DC Blocking Voltage	V_R	45	Volts	
Average Rectified Forward Current, $T_c \leq 125^\circ\text{C}$	$I_{F(ave)}$	75	Amps	
derating, forward current, $T_c \geq 125^\circ\text{C}$	di_F/dT	4	Amps/ $^\circ\text{C}$	
Nonrepetitive Peak Surge Current, $t_p = 8.3 \text{ ms}$, half-sinewave	I_{FSM}	500	Amps	
Peak Repetitive Reverse Surge Current, $t_p = 1 \mu\text{s}$, $f = 1 \text{ kHz}$	I_{RRM}	2	Amp	
Junction Temperature Range	T_j	-55 to +150	$^\circ\text{C}$	
Storage Temperature Range	T_{stg}	-55 to +150	$^\circ\text{C}$	
Thermal Resistance, Junction to Case:	θ_{JC}	1N6818 1N6818R	0.50 0.65	$^\circ\text{C/W}$

Mechanical Outline

ThinKey™4

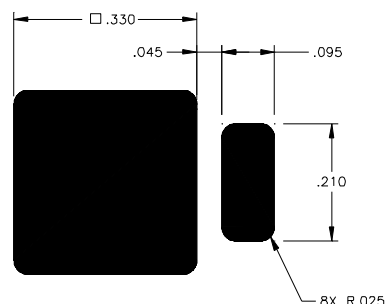
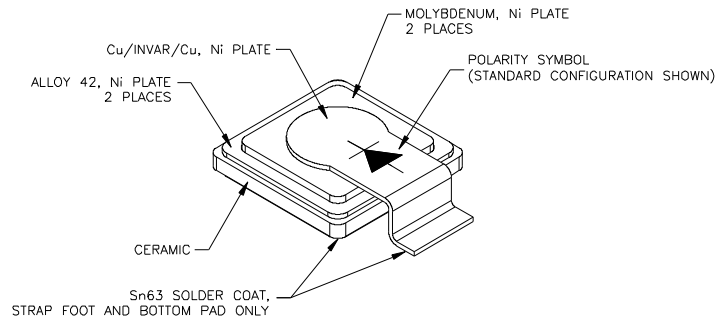
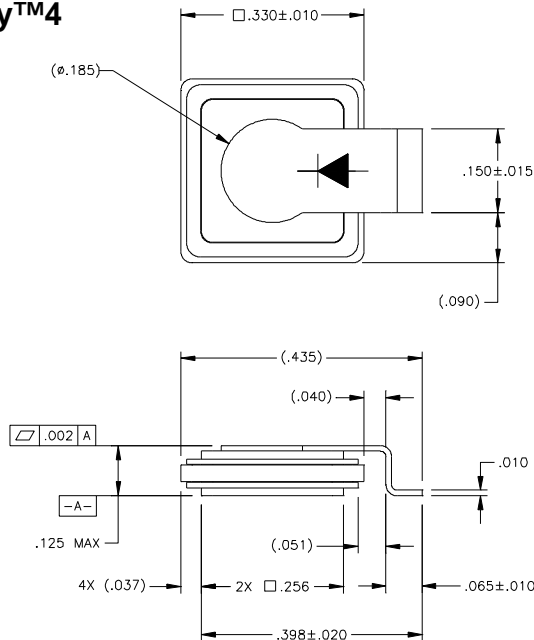

1N6818 (MSASC75H45F) 1N6818R (MSASC75H45FR)

Electrical Parameters

DESCRIPTION	SYMBOL	CONDITIONS	MIN	TYP.	MAX	UNIT
Reverse (Leakage)	IR ₂₅	VR= 45 Vdc, Tc= 25°C		0.75	7.5	mA
	IR ₁₂₅₋₁	VR= 12 Vdc, Tc= 125°C		65	-	mA
Current	IR ₁₂₅₋₂	VR= 36 Vdc, Tc= 125°C		125	-	mA
	IR ₁₂₅	VR= 45 Vdc, Tc= 125°C		175	300	mA
Forward Voltage pulse test, pw= 300 μs d/c≤ 2%	VF1	IF= 2 A, Tc= 25°C		290	-	mV
	VF2	IF= 10 A, Tc= 25°C		350	400	mV
	VF3	IF= 25 A, Tc= 25°C		415	480	mV
	VF4	IF= 50 A, Tc= 25°C		500	-	mV
	VF5	IF= 75 A, Tc= 25°C		575	650	mV
	VF6	IF= 100 A, Tc= 25°C		650	-	mV
	VF7	IF= 2 A, Tc= -55°C		390	-	mV
	VF8	IF= 10 A, Tc= -55°C		440	500	MV
	VF9	IF= 25 A, Tc= -55°C		480	550	MV
	VF10	IF= 50 A, Tc= -55°C		535	-	MV
	VF11	IF= 75 A, Tc= -55°C		580	660	mV
	VF12	IF= 2 A, Tc= 125°C		165	-	MV
	VF13	IF= 10 A, Tc= 125°C		250	310	MV
	VF14	IF= 25 A, Tc= 125°C		350	420	MV
	VF15	IF= 50 A, Tc= 125°C		475	-	MV
	VF16	IF= 75 A, Tc= 125°C		565	650	mV
		VFa	IF= 100 mA, Tc= 25°C		200	-
	VFb	IF= 100 mA, Tc= 125°C		60	-	mV
	VFc	IF= 100 mA, Tc= -55°C		325	-	mV
Junction Capacitance	Cj1	VR= 10 Vdc		1850	-	pF
	Cj2	VR= 5 Vdc		2500	3000	pF
Breakdown Voltage	BVR	IR= 5 mA, Tc= 25°C		58		V
		IR= 5 mA, Tc= -55°C	45	50		V

