

**VOIDLESS HERMETICALLY SEALED  
SURFACE MOUNT ULTRA FAST  
RECOVERY GLASS POWER  
RECTIFIERS**

**DESCRIPTION**

This "Ultrafast Recovery" rectifier diode series is ideal for high-reliability applications where a failure cannot be tolerated. These 3, 6, and 12 Amp rated rectifiers ( $T_{EC} = 70^{\circ}C$ ) in different package sizes with working peak reverse voltages from 50 to 150 volts are hermetically sealed using voidless-glass construction and an internal "Category I" metallurgical bond. These devices are also available in axial-lead package configurations for through-hole mounting by deleting the "US" suffix (see separate data sheet for 1N6073 thru 1N6081). Microsemi also offers numerous other rectifier products to meet higher and lower current ratings with various recovery time speed requirements including standard, fast and ultrafast device types in both through-hole and surface mount packages.

**APPEARANCE**

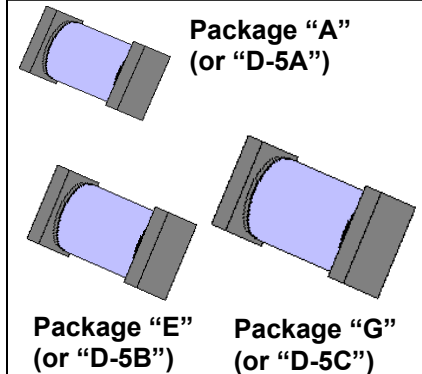

**IMPORTANT:** For the most current data, consult MICROSEMI's website: <http://www.microsemi.com>

**FEATURES**

- Popular 1N6073US to 1N6081US series
- Voidless hermetically-sealed glass package
- Extremely robust construction
- Triple-layer passivation
- Internal "Category I" Metallurgical bonds
- Options for screening in accordance with MIL-PRF-19500/503 for JAN, JANTX, JANTXV, or JANS by using a MQ, MX, MV or MSP prefix respectively, e.g. MX6076, MV6079, MSP6081, etc.
- Axial-leaded equivalents also available (see separate data sheet for 1N6073 thru 1N6081)

**APPLICATIONS / BENEFITS**

- Ultrafast recovery rectifier series 50 to 150 V
- Military and other high-reliability applications
- Switching power supplies or other applications requiring extremely fast switching & low forward loss
- High forward surge current capability
- Low thermal resistance for higher power
- Controlled avalanche with peak reverse power capability
- Inherently radiation hard as described in Microsemi MicroNote 050

**MAXIMUM RATINGS**

- Junction Temperature:  $-65^{\circ}C$  to  $+155^{\circ}C$
- Storage Temperature:  $-65^{\circ}C$  to  $+155^{\circ}C$
- Peak Forward Surge Current @  $25^{\circ}C$ : 35 Amps for 1N6073US-6075US, 75 Amps for 1N6076US-6078US, and 175 Amps for 1N6079US-6081US at 8.3 ms half-sine wave
- Average Rectified Forward Current ( $I_O$ ) at  $T_{EC} = +70^{\circ}C$ :  
1N6073US thru 1N6075US: 3.0 Amps  
1N6076US thru 1N6078US: 6.0 Amps  
1N6079US thru 1N6081US: 12.0 Amps  
Average Rectified Forward Current ( $I_O$ ) at  $T_A = 55^{\circ}C$ :  
1N6073US thru 1N6075US: 0.85 Amps  
1N6076US thru 1N6078US: 1.3 Amps  
1N6079US thru 1N6081US: 2.0 Amps
- Thermal Resistance ( $R_{\theta JEC}$ ):  $13^{\circ}C/W$  for 1N6073US-6075US,  $8.5^{\circ}C/W$  for 1N6076US-6078US, and  $5.0^{\circ}C/W$  for 1N6079US-6081US
- Solder temperature:  $260^{\circ}C$  for 10 s (maximum)

**MECHANICAL AND PACKAGING**

- CASE: Hermetically sealed voidless hard glass with Tungsten slugs
- TERMINATIONS: End caps are Copper with Tin/Lead (Sn/Pb) finish. Note: Previous inventory had solid Silver end caps with Tin/Lead finish.
- MARKING: None
- POLARITY: Cathode indicated by band
- Tape & Reel option: Standard per EIA-481-B
- Weight: 1N6073 thru 1N6075: 193 mg  
1N6076 thru 1N6078: 539 mg  
1N6079 thru 1N6081: 1100 mg
- See package dimensions and recommended pad layouts on last page for all three package sizes

**VOIDLESS HERMETICALLY SEALED  
SURFACE MOUNT ULTRA FAST  
RECOVERY GLASS POWER  
RECTIFIERS**

**ELECTRICAL CHARACTERISTICS @ 25°C unless otherwise specified**

TYPE	WORKING PEAK REVERSE VOLTAGE $V_{RWM}$	MAXIMUM FORWARD VOLTAGE (PULSED) $V_F @ I_F$	PULSED TEST CURRENT $I_F$	AVERAGE RECTIFIED CURRENT $I_O$ @ $T_{EC} = 70^\circ C$	AVERAGE RECTIFIED CURRENT $I_O$ @ $T_A = 55^\circ C$	MAXIMUM REVERSE CURRENT $I_R @ V_{RWM}$	MAXIMUM REVERSE RECOVERY TIME* $t_{rr}$	MAXIMUM SURGE CURRENT $I_{FSM}$
1N6073US	50	2.04	9.4	3.0	0.85	1.0	30	35
1N6074US	100	2.04	9.4	3.0	0.85	1.0	30	35
1N6075US	150	2.04	9.4	3.0	0.85	1.0	30	35
1N6076US	50	1.76	18.8	6.0	1.3	5.0	30	75
1N6077US	100	1.76	18.8	6.0	1.3	5.0	30	75
1N6078US	150	1.76	18.8	6.0	1.3	5.0	30	75
1N6079US	50	1.50	37.7	12.0	2.0	10.0	30	175
1N6080US	100	1.50	37.7	12.0	2.0	10.0	30	175
1N6081US	150	1.50	37.7	12.0	2.0	10.0	30	175

\*NOTE:  $I_F = 0.5 A$ ,  $I_{RM} = 1.0 A$ , and  $I_{R(REC)} = 0.25 A$

**SYMBOLS & DEFINITIONS**

Symbol	Definition
$V_{BR}$	Minimum Breakdown Voltage: The minimum voltage the device will exhibit at a specified current.
$V_{RWM}$	Working Peak Reverse Voltage: The maximum peak voltage that can be applied over the operating temperature range.
$V_F$	Maximum Forward Voltage: The maximum forward voltage the device will exhibit at a specified current.
$I_R$	Maximum Leakage Current: The maximum leakage current that will flow at the specified voltage and temperature.
$t_{rr}$	Reverse Recovery Time: The time interval between the instant the current passes through zero when changing from the forward direction to the reverse direction and a specified recovery decay point after a peak reverse current is reached.

**PACKAGE DIMENSIONS**

**PACKAGE A (1N6073US thru 1N6075US)**

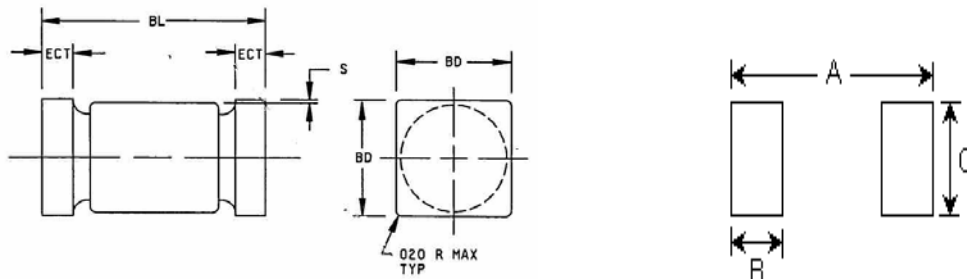

NOTE: This Package Outline has also previously been identified as "D-5A"

	INCHES		mm	
	MIN	MAX	MIN	MAX
BD	.097	.103	2.46	2.62
BL	.185	.200	4.70	5.08
ECT	.019	.028	0.48	0.71
S	.003	---	0.08	---

**PAD LAYOUT**

	INCHES	mm
A	0.246	6.25
B	0.067	1.70
C	0.105	2.67

Note: If mounting requires adhesive separate from the solder, an additional 0.060 inch diameter contact may be placed in the center between the pads as an optional spot for cement.

**PACKAGE E (1N6076US thru 1N6078US)**

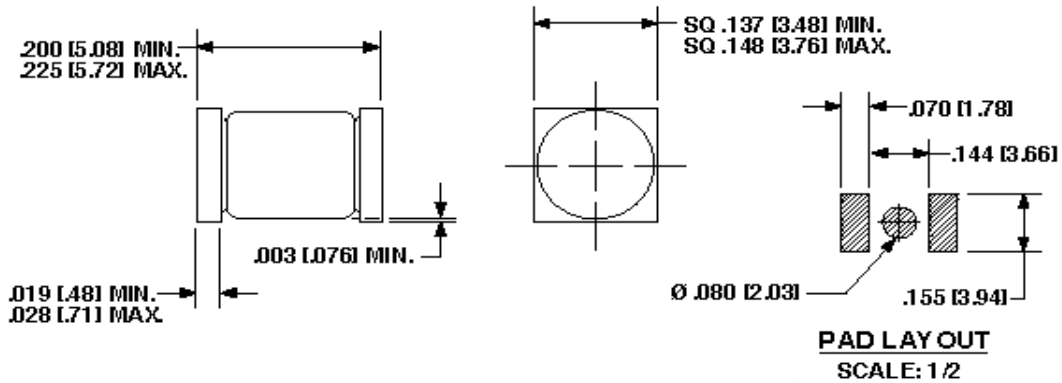

NOTE: DIMENSIONS IN INCHES [MM]

**E-MELF-PKG (D-5B)**

Note: If mounting requires adhesive separate from the solder, an additional 0.080 inch diameter contact may be placed in the center between the pads as an optional spot for cement as shown in the pad layout.

**PACKAGE G (1N6079US thru 1N6081US)**

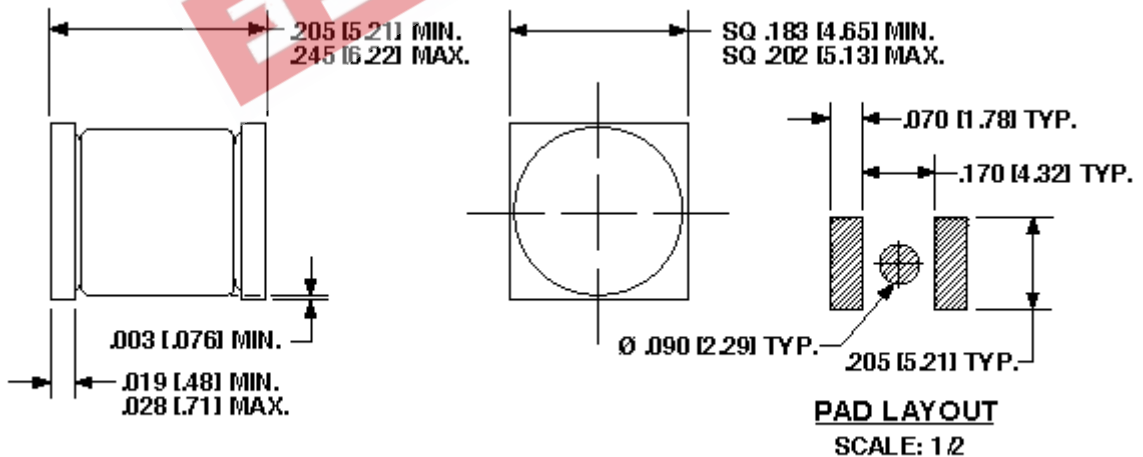

NOTE: DIMENSIONS IN INCHES [MM]

**G-MELF-PKG (D-5C)**

Note: If mounting requires adhesive separate from the solder, an additional 0.090 inch diameter contact may be placed in the center between the pads as an optional spot for cement as shown in the pad layout.