

- 1N6639US THRU 1N6641US AVAILABLE IN JAN, JANTX, JANTXV AND JANS PER MIL-PRF-19500/609
- SWITCHING DIODES
- NON-CAVITY GLASS PACKAGE
- METALLURGICALLY BONDED

1N6639US  
1N6640US  
1N6641US

### MAXIMUM RATINGS

Operating Temperature: -65°C to +175°C  
Storage Temperature: -65°C to +175°C  
Operating Current: 300 mA  
Derating: 4.6 mA/°C Above  $T_{EC} = +110^{\circ}C$   
Surge Current:  $I_{FSM} = 2.5A$ ,  $P_W = 8.3ms$

### ELECTRICAL CHARACTERISTICS @ 25°C, unless otherwise specified.

TYPES	$V_{BRR}$ @ 10 $\mu A$	$V_{RWM}$	$I_{R1}$ @ $T_A = +25^{\circ}C$ $V_R = V_{RWM}$	$I_{R2}$ @ $T_A = +150^{\circ}C$ $V_R = V_{RWM}$	$T_{FR}$ $I_F = 200 mA$	$T_{RR}$ $I_R = 10 mA$ $I_F = 10 mA$ $R_L = 100 \Omega$	$C_T$ $V_R = 0$
	V(pk)	V(pk)	nA dc	$\mu A$ dc	ns	ns	pF
1N6639US	100	75	100	100	10	4.0	2.5
1N6640US	75	50	100	100	10	4.0	2.5
1N6641US	75	50	100	100	10	5.0	3.0

### FORWARD VOLTAGE:

TYPES	$V_F$ @ $I_F$		mA (PULSED)
	VdC		
	MIN	MAX	
1N6639US	-	1.20	500
1N6640US	0.54	0.62	1
	0.76	0.86	50
	0.82	0.92	100
	0.87	1.00	200
1N6641US	-	1.10	200

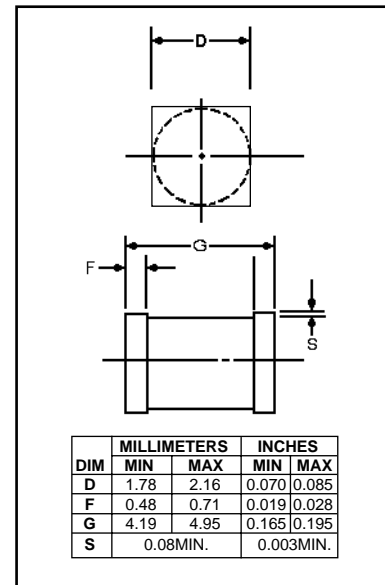

FIGURE 1

### DESIGN DATA

**CASE:** D-5D, Hermetically sealed glass case, per MIL-PRF- 19500/609

**LEAD FINISH:** Tin / Lead

**THERMAL RESISTANCE:** ( $R_{\theta JEC}$ ): 50 °C/W maximum at L = 0

**THERMAL IMPEDANCE:** ( $Z_{\theta JX}$ ): 25 °C/W maximum

**POLARITY:** Cathode end is banded

**MOUNTING SURFACE SELECTION:**  
The Axial Coefficient of Expansion (COE) of this device is approximately + 4PPM / °C. The COE of the Mounting Surface System should be selected to provide a suitable match with this device.



**COMPENSATED DEVICES INCORPORATED**

22 COREY STREET, MELROSE, MASSACHUSETTS 02176  
PHONE (781) 665-1071 FAX (781) 665-7379  
WEBSITE: <http://www.cdi-diodes.com> E-mail: [mail@cdi-diodes.com](mailto:mail@cdi-diodes.com)

# IN6639US thru IN6641US

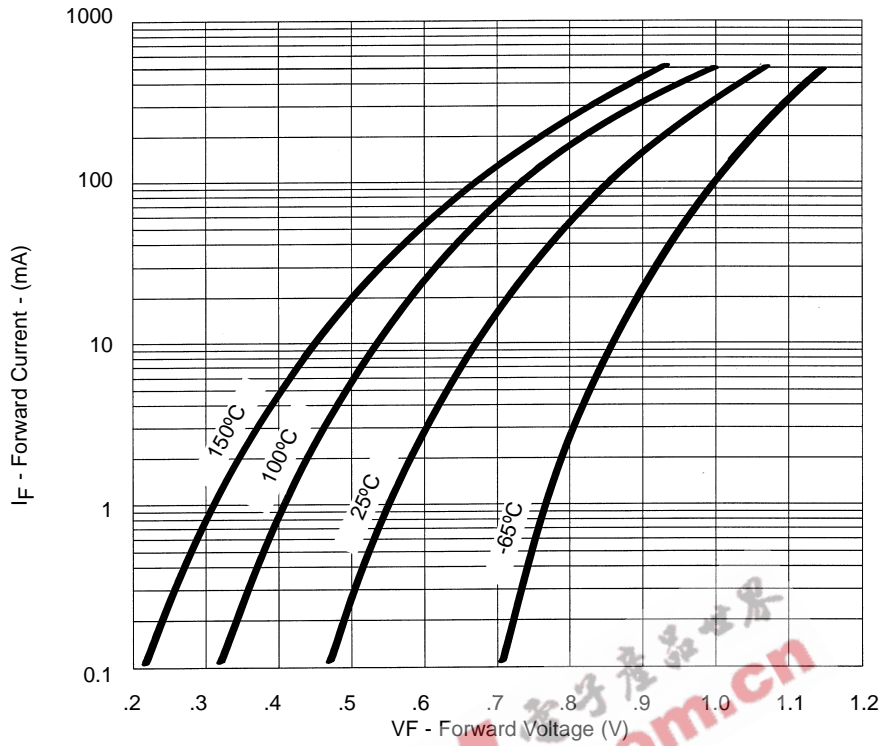

**FIGURE 2**  
Typical Forward Current  
vs Forward Voltage

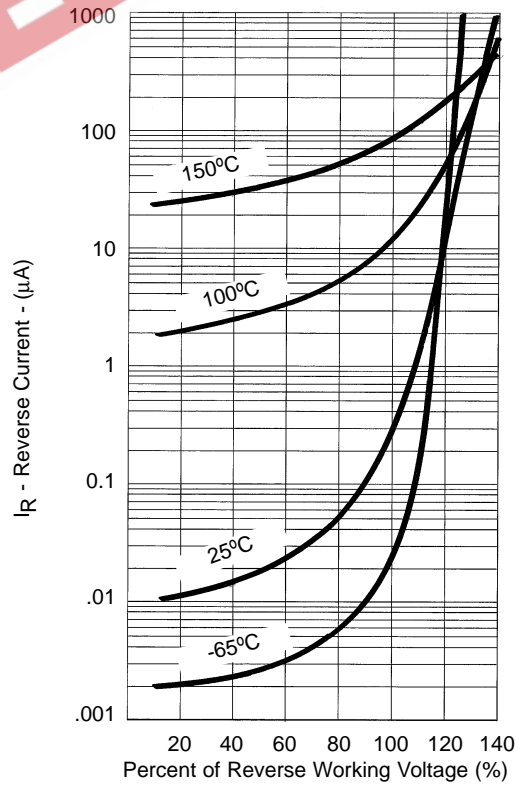

**FIGURE 3**  
Typical Reverse Current  
vs Reverse Voltage

**NOTE :** All temperatures shown on graphs are junction temperatures