

**MSASC25W45K
 (1N6816)
 MSASC25W45KR
 (1N6816R)**

**45 Volts
 25 Amps**

**LOW LEAKAGE
 SCHOTTKY DIODE**

Features

- Tungsten schottky barrier
- Oxide passivated structure for very low leakage currents
- Guard ring protection for increased reverse energy capability
- Epitaxial structure minimizes forward voltage drop
- Hermetically sealed, low profile ceramic surface mount power package
- Low package inductance
- Very low thermal resistance
- Available as standard polarity (strap-to-anode, 1N6816) and reverse polarity (strap-to-cathode: 1N6816R)

Maximum Ratings @ 25°C (unless otherwise specified)

DESCRIPTION	SYMBOL	MAX.	UNIT
Peak Repetitive Reverse Voltage	V_{RRM}	45	Volts
Working Peak Reverse Voltage	V_{RWM}	45	Volts
DC Blocking Voltage	V_R	45	Volts
Average Rectified Forward Current, $T_c \leq 145^\circ\text{C}$	$I_{F(ave)}$	25	Amps
derating, forward current, $T_c \geq 145^\circ\text{C}$	dI_F/dT	(3.3)	Amps/ $^\circ\text{C}$
Nonrepetitive Peak Surge Current, $t_p = 8.3$ ms, half-sinewave	I_{FSM}	125	Amps
Peak Repetitive Reverse Surge Current, $t_p = 1\mu\text{s}$, $f = 1$ kHz	I_{RRM}	2	Amp
Junction Temperature Range	T_j	-55 to +175	$^\circ\text{C}$
Storage Temperature Range	T_{stg}	-55 to +175	$^\circ\text{C}$
Thermal Resistance, Junction to Case:			$^\circ\text{C/W}$
	1N6816	1.25	
	1N6816R	1.35	

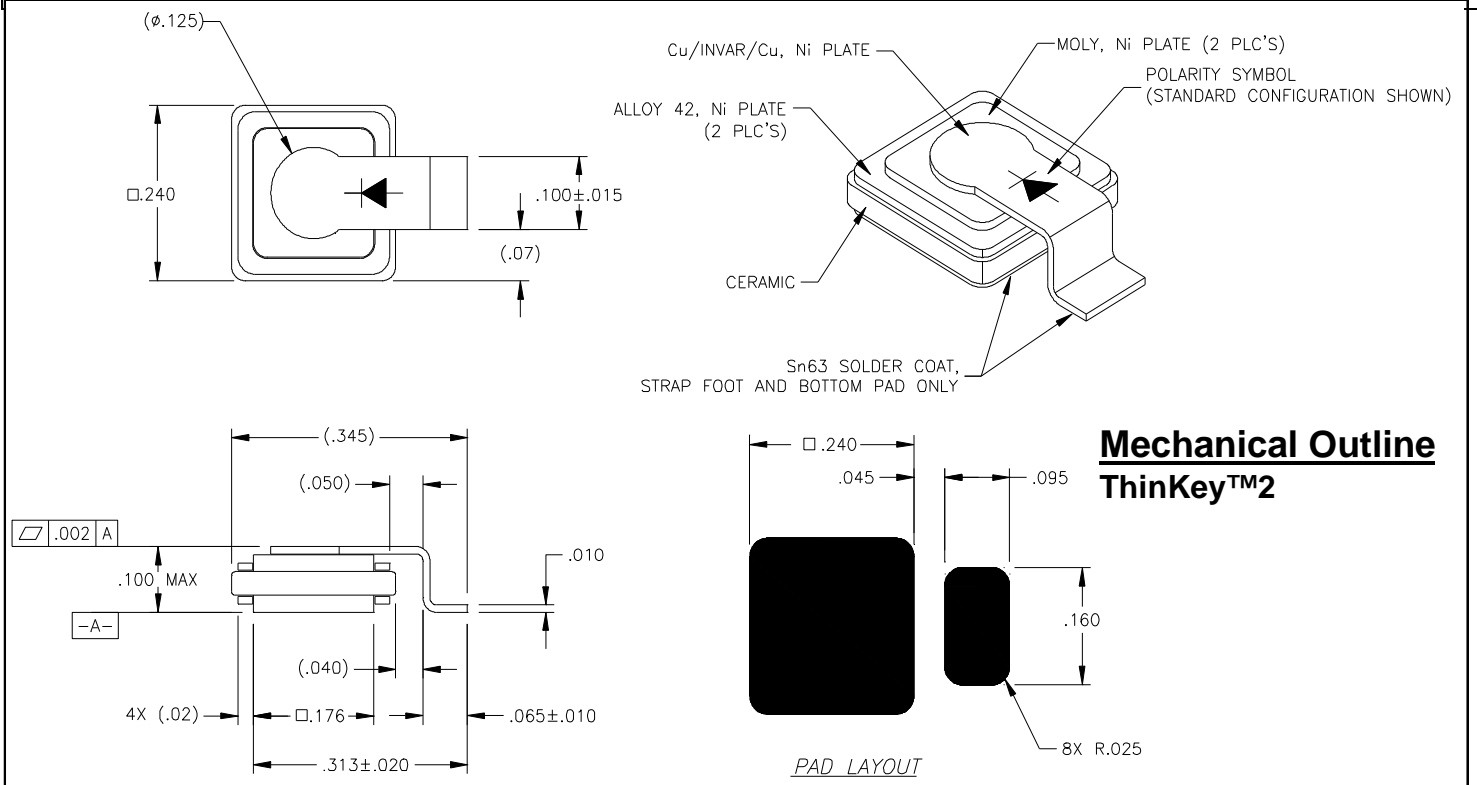

MSASC25W45K (1N6816) MSASC25W45KR (1N6816R)



Electrical Parameters

DESCRIPTION	SYMBOL	CONDITIONS	MIN	TYP.	MAX	UNIT
Reverse (Leakage) Current	IR ₂₅	VR= 45 Vdc, Tc= 25°C		5	300	μA
	IR ₁₂₅	VR= 45 Vdc, Tc= 125°C		1.5	10	mA
Forward Voltage pulse test, pw= 300 μs d/c≤ 2%	VF1	IF= 5A, Tc= 25°C		540	600	mV
	VF2	IF= 10A, Tc= 25°C		590	675	mV
	VF3	IF= 20A, Tc= 25°C		680	775	mV
	VF4	IF= 50A, Tc= 25°C		850	-	mV
	VF5	IF= 10A, Tc= -55°C		680	775	mV
	VF6	IF= 10A, Tc= 125°C		500	-	mV
Junction Capacitance	Cj1	VR= 10 Vdc		525	600	pF
	Cj2	VR= 5 Vdc		725		pF
Breakdown Voltage	BVR	IR= 1 mA, Tc= 25°C		55		V
		IR= 1 mA, Tc= -55°C	45	50		V

