

# BAS40 series; 1PSxxSB4x series

General-purpose Schottky diodes

Rev. 07 — 12 May 2006

Product data sheet

## 1. Product profile

### 1.1 General description

General-purpose Schottky diodes in small Surface-Mounted Device (SMD) plastic packages.

Table 1. Product overview

Type number	Package		Configuration
	Philips	JEITA	
1PS70SB40	SOT323	SC-70	single diode
1PS76SB40	SOD323	SC-76	single diode
1PS79SB40	SOD523	SC-79	single diode
BAS40	SOT23	-	single diode
BAS40H	SOD123F	-	single diode
BAS40L	SOD882	-	single diode
BAS40W	SOT323	SC-70	single diode
1PS70SB44	SOT323	SC-70	dual series
BAS40-04	SOT23	-	dual series
BAS40-04W	SOT323	SC-70	dual series
1PS70SB45	SOT323	SC-70	dual common cathode
1PS75SB45	SOT416	SC-75	dual common cathode
BAS40-05	SOT23	-	dual common cathode
BAS40-05W	SOT323	SC-70	dual common cathode
1PS70SB46	SOT323	SC-70	dual common anode
BAS40-06	SOT23	-	dual common anode
BAS40-06W	SOT323	SC-70	dual common anode
BAS40-07	SOT143B	-	dual isolated
BAS40-07V	SOT666	-	dual isolated
BAS40-05V	SOT666	-	quadruple common cathode/ common cathode
1PS88SB48	SOT363	SC-88	quadruple common cathode/ common cathode
BAS40XY	SOT363	SC-88	quadruple; 2 series

**PHILIPS**

## 1.2 Features

- High switching speed
- High breakdown voltage
- Low leakage current
- Low capacitance

## 1.3 Applications

- Ultra high-speed switching
- Voltage clamping

## 1.4 Quick reference data

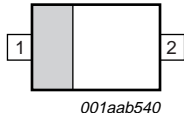

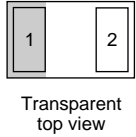

Table 2. Quick reference data

Symbol	Parameter	Conditions	Min	Typ	Max	Unit
<b>Per diode</b>						
$I_F$	forward current		-	-	120	mA
$V_F$	forward voltage	$I_F = 1 \text{ mA}$	[1]	-	380	mV
$V_R$	reverse voltage		-	-	40	V

[1] Pulse test:  $t_p \leq 300 \mu\text{s}$ ;  $\delta \leq 0.02$ .

## 2. Pinning information

Table 3. Pinning

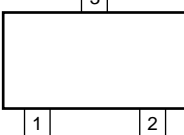
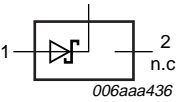
Pin	Description	Conditions	Simplified outline	Symbol
<b>BAS40H; 1PS76SB40; 1PS79SB40</b>				
1	cathode	[1]	 <p>001aab540</p>	 <p>sym001</p>
2	anode			
<b>BAS40L</b>				
1	cathode	[1]	 <p>Transparent top view</p>	 <p>sym001</p>
2	anode			
<b>BAS40; BAS40W; 1PS70SB40</b>				
1	anode		 <p>006aaa144</p>	 <p>006aaa436</p>
2	not connected			
3	cathode			

**Table 3. Pinning ...continued**

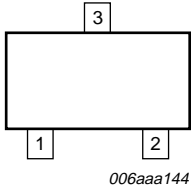
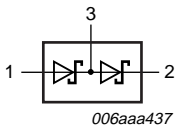
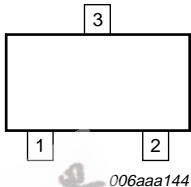
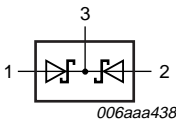
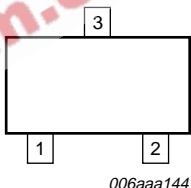
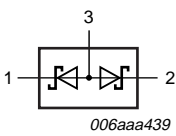
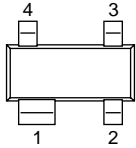
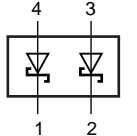
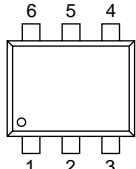
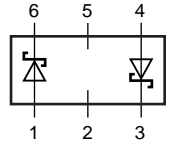
Pin	Description	Simplified outline	Symbol
<b>BAS40-04; BAS40-04W; 1PS70SB44</b>			
1	anode (diode 1)	 <p>006aaa144</p>	 <p>006aaa437</p>
2	cathode (diode 2)		
3	cathode (diode 1), anode (diode 2)		
<b>BAS40-05; BAS40-05W; 1PS70SB45; 1PS75SB45</b>			
1	anode (diode 1)	 <p>006aaa144</p>	 <p>006aaa438</p>
2	anode (diode 2)		
3	cathode (diode 1), cathode (diode 2)		
<b>BAS40-06; BAS40-06W; 1PS70SB46</b>			
1	cathode (diode 1)	 <p>006aaa144</p>	 <p>006aaa439</p>
2	cathode (diode 2)		
3	anode (diode 1), anode (diode 2)		
<b>BAS40-07</b>			
1	cathode (diode 1)		 <p>006aaa434</p>
2	cathode (diode 2)		
3	anode (diode 2)		
4	anode (diode 1)		
<b>BAS40-07V</b>			
1	anode (diode 1)		 <p>006aaa440</p>
2	not connected		
3	cathode (diode 2)		
4	anode (diode 2)		
5	not connected		
6	cathode (diode 1)		

**Table 3. Pinning ...continued**

Pin	Description	Simplified outline	Symbol
<b>BAS40-05V; 1PS88SB48</b>			
1	anode (diode 1)	<p>001aab555</p>	<p>006aaa446</p>
2	anode (diode 2)		
3	cathode (diode 3), cathode (diode 4)		
4	anode (diode 3)		
5	anode (diode 4)		
6	cathode (diode 1), cathode (diode 2)		
<b>BAS40XY</b>			
1	anode (diode 1)		<p>006aaa256</p>
2	cathode (diode 2)		
3	anode (diode 3), cathode (diode 4)		
4	anode (diode 4)		
5	cathode (diode 3)		
6	cathode (diode 1), anode (diode 2)		

[1] The marking bar indicates the cathode.

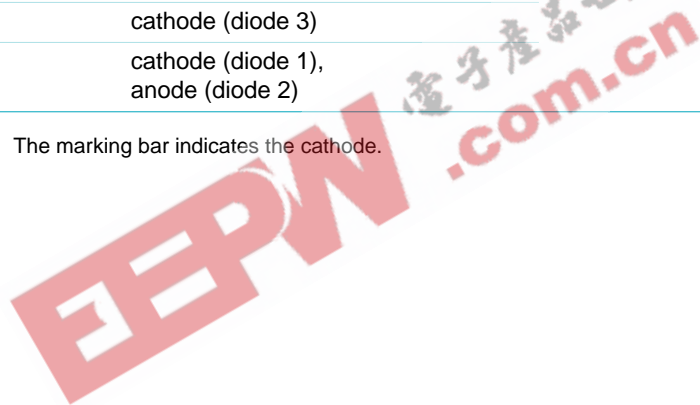

### 3. Ordering information

Table 4. Ordering information

Type number	Package		Version
	Name	Description	
1PS70SB40	SC-70	plastic surface-mounted package; 3 leads	SOT323
1PS76SB40	SC-76	plastic surface-mounted package; 2 leads	SOD323
1PS79SB40	SC-79	plastic surface-mounted package; 2 leads	SOD523
BAS40	-	plastic surface-mounted package; 3 leads	SOT23
BAS40H	-	plastic surface-mounted package; 2 leads	SOD123F
BAS40L	-	leadless ultra small plastic package; 2 terminals; body 1.0 × 0.6 × 0.5 mm	SOD882
BAS40W	SC-70	plastic surface-mounted package; 3 leads	SOT323
1PS70SB44	SC-70	plastic surface-mounted package; 3 leads	SOT323
BAS40-04	-	plastic surface-mounted package; 3 leads	SOT23
BAS40-04W	SC-70	plastic surface-mounted package; 3 leads	SOT323
1PS70SB45	SC-70	plastic surface-mounted package; 3 leads	SOT323
1PS75SB45	SC-75	plastic surface-mounted package; 3 leads	SOT416
BAS40-05	-	plastic surface-mounted package; 3 leads	SOT23
BAS40-05W	SC-70	plastic surface-mounted package; 3 leads	SOT323
1PS70SB46	SC-70	plastic surface-mounted package; 3 leads	SOT323
BAS40-06	-	plastic surface-mounted package; 3 leads	SOT23
BAS40-06W	SC-70	plastic surface-mounted package; 3 leads	SOT323
BAS40-07	-	plastic surface-mounted package; 4 leads	SOT143B
BAS40-07V	-	plastic surface-mounted package; 6 leads	SOT666
BAS40-05V	-	plastic surface-mounted package; 6 leads	SOT666
1PS88SB48	SC-88	plastic surface-mounted package; 6 leads	SOT363
BAS40XY	SC-88	plastic surface-mounted package; 6 leads	SOT363

## 4. Marking

**Table 5. Marking codes**

Type number	Marking code <sup>[1]</sup>	Type number	Marking code <sup>[1]</sup>
1PS70SB40	6*3	1PS75SB45	45
1PS76SB40	S4	BAS40-05	45*
1PS79SB40	T	BAS40-05W	65*
BAS40	43*	1PS70SB46	6*6
BAS40H	AJ	BAS40-06	46*
BAS40L	S6	BAS40-06W	66*
BAS40W	63*	BAS40-07	47*
1PS70SB44	6*4	BAS40-07V	67
BAS40-04	44*	BAS40-05V	65
BAS40-04W	64*	1PS88SB48	8*5
1PS70SB45	6*5	BAS40XY	40*

- [1] \* = -: made in Hong Kong  
 \* = p: made in Hong Kong  
 \* = t: made in Malaysia  
 \* = W: made in China

## 5. Limiting values

**Table 6. Limiting values**

*In accordance with the Absolute Maximum Rating System (IEC 60134).*

Symbol	Parameter	Conditions	Min	Max	Unit
<b>Per diode</b>					
$V_R$	reverse voltage		-	40	V
$I_F$	forward current		-	120	mA
$I_{FRM}$	repetitive peak forward current	$t_p \leq 1 \text{ s}; \delta \leq 0.5$	-	120	mA
$I_{FSM}$	non-repetitive peak forward current	$t_p \leq 10 \text{ ms}$	[1] -	200	mA
$T_j$	junction temperature		-	150	°C
$T_{amb}$	ambient temperature		-65	+150	°C
$T_{stg}$	storage temperature		-65	+150	°C

- [1]  $T_j = 25 \text{ °C}$  prior to surge.

## 6. Thermal characteristics

**Table 7. Thermal characteristics**

Symbol	Parameter	Conditions	Min	Typ	Max	Unit
<b>Per device</b>						
$R_{th(j-a)}$	thermal resistance from junction to ambient	in free air	[1]			
	SOT23		-	-	500	K/W
	SOT143B		-	-	500	K/W
	SOT363 (1PS88SB48)		-	-	416	K/W
	SOT416		-	-	833	K/W
	SOT666 (BAS40-05V)		[2]	-	225	K/W
	SOT666 (BAS40-07V)		[2]	-	416	K/W
	SOD123F		[2]	-	330	K/W
	SOD323		-	-	450	K/W
	SOD523		[2]	-	450	K/W
	SOD882		[2]	-	500	K/W
SOT323		-	-	625	K/W	
$R_{th(j-sp)}$	thermal resistance from junction to solder point					
	SOT363 (BAS40XY)		[3]	-	260	K/W

[1] Device mounted on an FR4 Printed-Circuit Board (PCB), single-sided copper, tin-plated and standard footprint.

[2] Reflow soldering is the only recommended soldering method.

[3] Soldering point at pins 2, 3, 5 and 6.

## 7. Characteristics

**Table 8. Characteristics**

$T_{amb} = 25\text{ }^{\circ}\text{C}$  unless otherwise specified.

Symbol	Parameter	Conditions	Min	Typ	Max	Unit
<b>Per diode</b>						
$V_F$	forward voltage		[1]			
		$I_F = 1\text{ mA}$	-	-	380	mV
		$I_F = 10\text{ mA}$	-	-	500	mV
		$I_F = 40\text{ mA}$	-	-	1	V
$I_R$	reverse current	$V_R = 30\text{ V}$	-	-	1	$\mu\text{A}$
		$V_R = 40\text{ V}$	-	-	10	$\mu\text{A}$
$C_d$	diode capacitance	$V_R = 0\text{ V}$ ; $f = 1\text{ MHz}$	-	-	5	pF

[1] Pulse test:  $t_p \leq 300\text{ }\mu\text{s}$ ;  $\delta \leq 0.02$ .

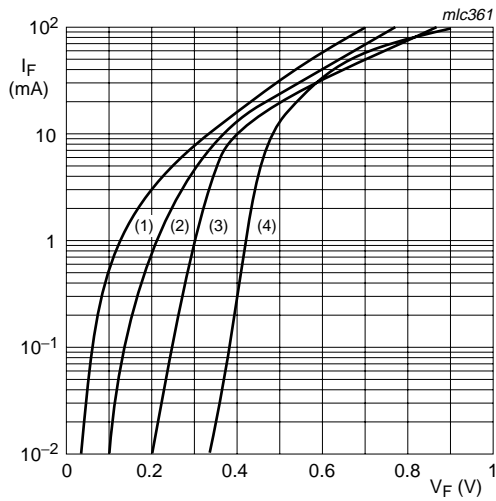

- (1)  $T_{amb} = 125\text{ }^{\circ}\text{C}$
- (2)  $T_{amb} = 85\text{ }^{\circ}\text{C}$
- (3)  $T_{amb} = 25\text{ }^{\circ}\text{C}$
- (4)  $T_{amb} = -40\text{ }^{\circ}\text{C}$

**Fig 1. Forward current as a function of forward voltage; typical values**

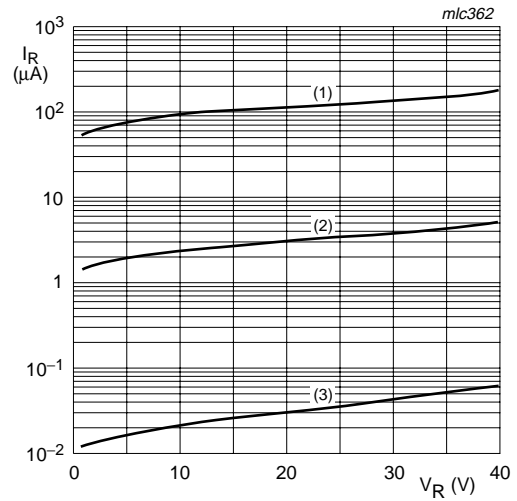

- (1)  $T_{amb} = 125\text{ }^{\circ}\text{C}$
- (2)  $T_{amb} = 85\text{ }^{\circ}\text{C}$
- (3)  $T_{amb} = 25\text{ }^{\circ}\text{C}$

**Fig 2. Reverse current as a function of reverse voltage; typical values**

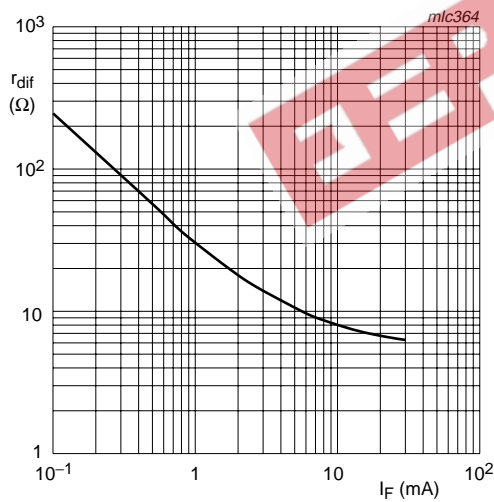

$f = 10\text{ kHz}$

**Fig 3. Differential resistance as a function of forward current; typical values**

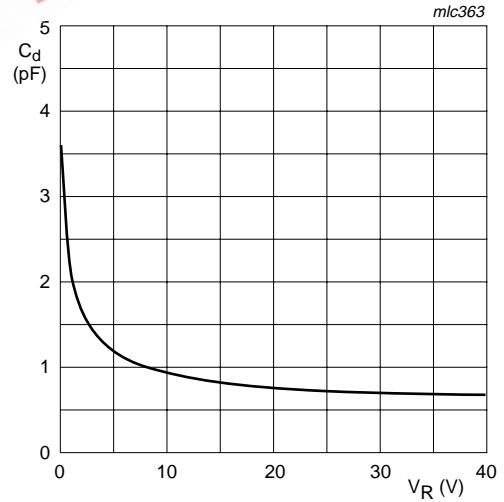

$T_{amb} = 25\text{ }^{\circ}\text{C}; f = 1\text{ MHz}$

**Fig 4. Diode capacitance as a function of reverse voltage; typical values**



**8. Package outline**

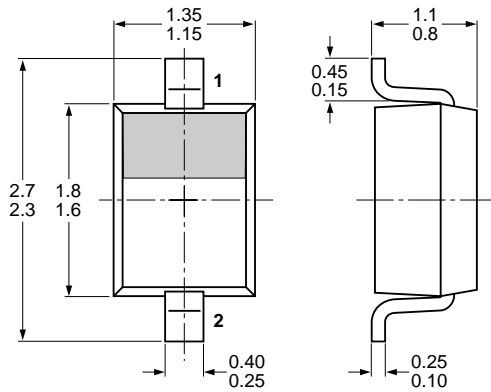

Dimensions in mm

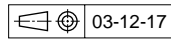

**Fig 5. Package outline SOD323 (SC-76)**

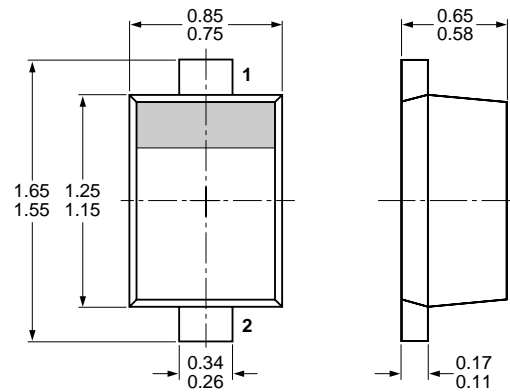

Dimensions in mm

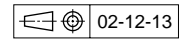

**Fig 6. Package outline SOD523 (SC-79)**

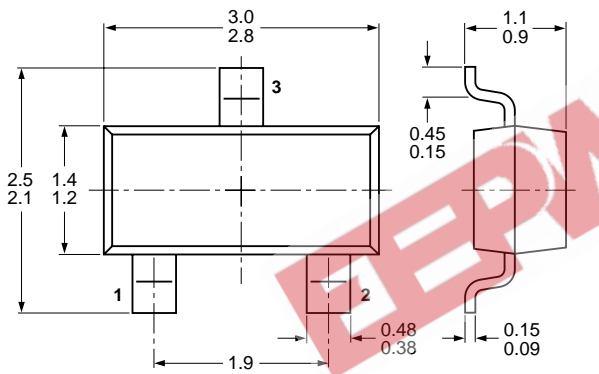

Dimensions in mm



**Fig 7. Package outline SOT23 (TO-236AB)**

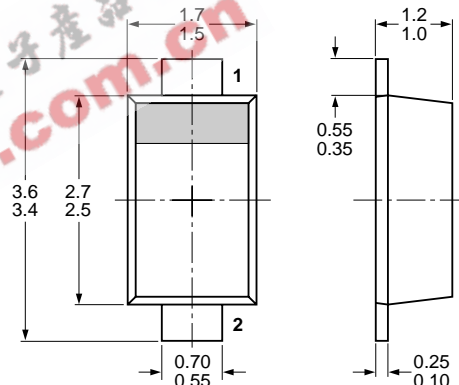

Dimensions in mm

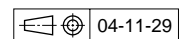

**Fig 8. Package outline SOD123F**

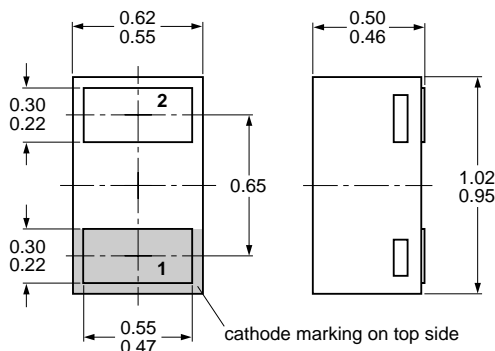

Dimensions in mm

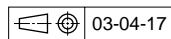

**Fig 9. Package outline SOD882**

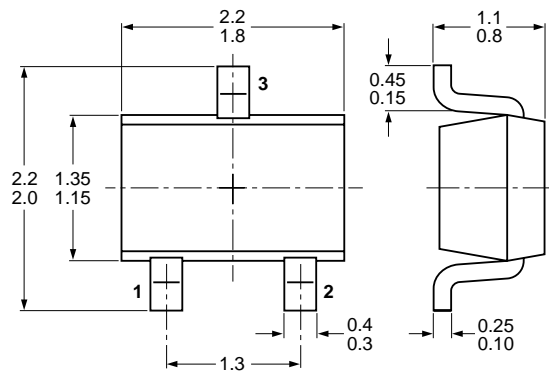

Dimensions in mm

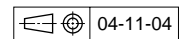

**Fig 10. Package outline SOT323 (SC-70)**

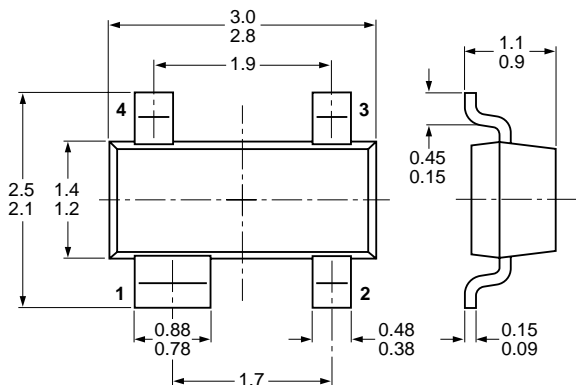

Dimensions in mm

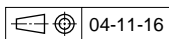
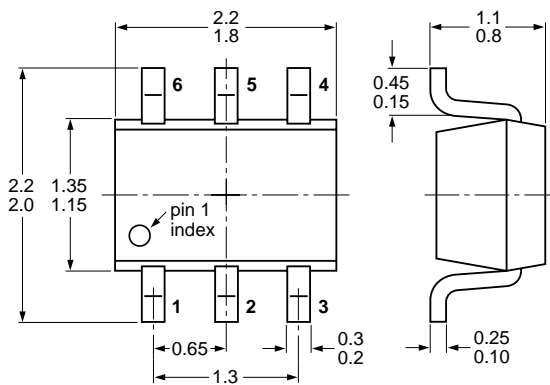

Fig 11. Package outline SOT143B



Dimensions in mm

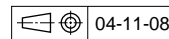
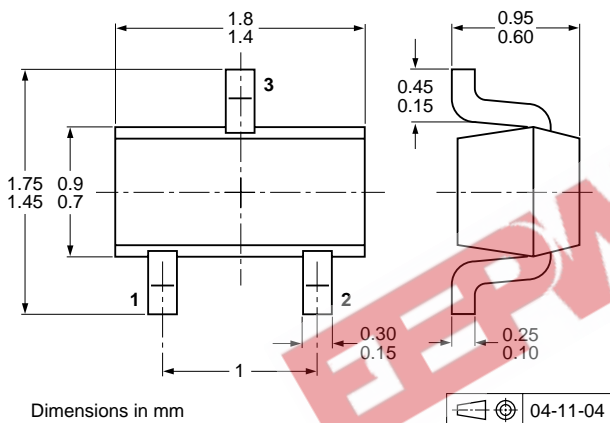

Fig 12. Package outline SOT363 (SC-88)



Dimensions in mm

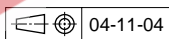
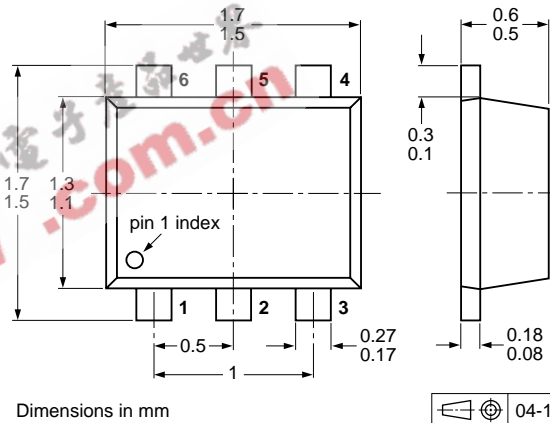

Fig 13. Package outline SOT416 (SC-75)



Dimensions in mm

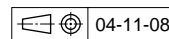

Fig 14. Package outline SOT666

## 9. Packing information

**Table 9. Packing methods**

The indicated -xxx are the last three digits of the 12NC ordering code.<sup>[1]</sup>

Type number	Package	Description	Packing quantity			
			3000	4000	8000	10000
1PS70SB40	SOT323	4 mm pitch, 8 mm tape and reel	-115	-	-	-135
1PS76SB40	SOD323	4 mm pitch, 8 mm tape and reel	-115	-	-	-135
1PS79SB40	SOD523	2 mm pitch, 8 mm tape and reel	-	-	-315	-
		4 mm pitch, 8 mm tape and reel	-115	-	-	-135
BAS40	SOT23	4 mm pitch, 8 mm tape and reel	-215	-	-	-235
BAS40H	SOD123F	4 mm pitch, 8 mm tape and reel	-115	-	-	-135
BAS40L	SOD882	2 mm pitch, 8 mm tape and reel	-	-	-	-315
BAS40W	SOT323	4 mm pitch, 8 mm tape and reel	-115	-	-	-135
1PS70SB44	SOT323	4 mm pitch, 8 mm tape and reel	-115	-	-	-135
BAS40-04	SOT23	4 mm pitch, 8 mm tape and reel	-215	-	-	-235
BAS40-04W	SOT323	4 mm pitch, 8 mm tape and reel	-115	-	-	-135
1PS70SB45	SOT323	4 mm pitch, 8 mm tape and reel	-115	-	-	-135
1PS75SB45	SOT416	4 mm pitch, 8 mm tape and reel	-115	-	-	-135
BAS40-05	SOT23	4 mm pitch, 8 mm tape and reel	-215	-	-	-235
BAS40-05W	SOT323	4 mm pitch, 8 mm tape and reel	-115	-	-	-135
1PS70SB46	SOT323	4 mm pitch, 8 mm tape and reel	-115	-	-	-135
BAS40-06	SOT23	4 mm pitch, 8 mm tape and reel	-215	-	-	-235
BAS40-06W	SOT323	4 mm pitch, 8 mm tape and reel	-115	-	-	-135
BAS40-07	SOT143B	4 mm pitch, 8 mm tape and reel	-215	-	-	-235
BAS40-07V	SOT666	2 mm pitch, 8 mm tape and reel	-	-	-315	-
		4 mm pitch, 8 mm tape and reel	-	-115	-	-
BAS40-05V	SOT666	2 mm pitch, 8 mm tape and reel	-	-	-315	-
		4 mm pitch, 8 mm tape and reel	-	-115	-	-
1PS88SB48	SOT363	4 mm pitch, 8 mm tape and reel; T1 <sup>[2]</sup>	-115	-	-	-135
		4 mm pitch, 8 mm tape and reel; T2 <sup>[3]</sup>	-125	-	-	-165
BAS40XY	SOT363	4 mm pitch, 8 mm tape and reel; T1 <sup>[2]</sup>	-115	-	-	-135
		4 mm pitch, 8 mm tape and reel; T2 <sup>[3]</sup>	-125	-	-	-165

[1] For further information and the availability of packing methods, see [Section 13](#).

[2] T1: normal taping

[3] T2: reverse taping

**10. Soldering**

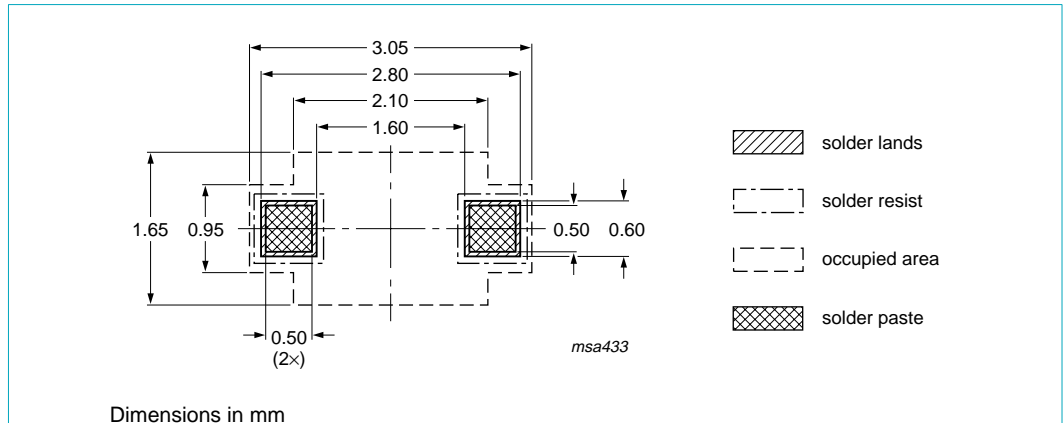

**Fig 15. Reflow soldering footprint SOD323 (SC-76)**

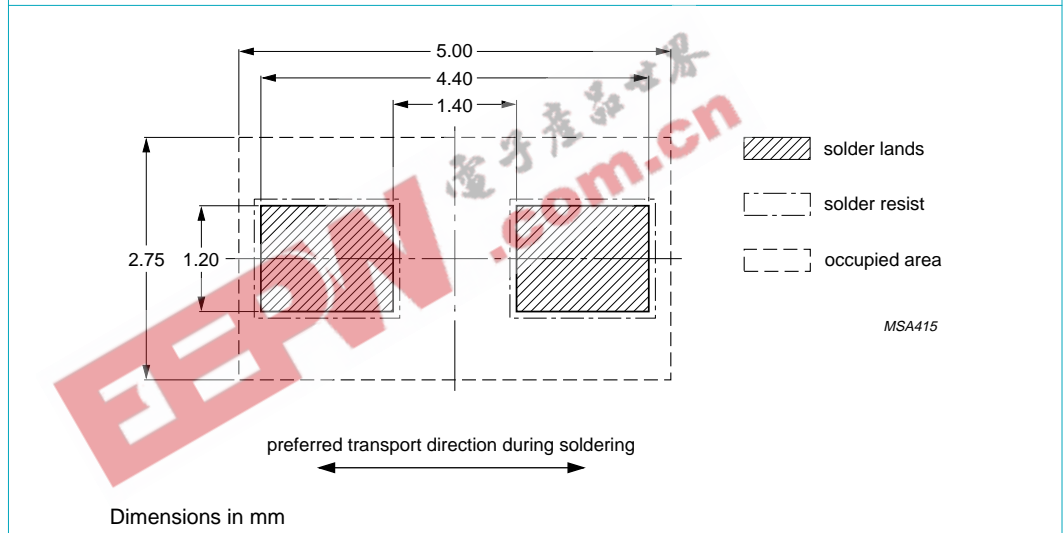

**Fig 16. Wave soldering footprint SOD323 (SC-76)**

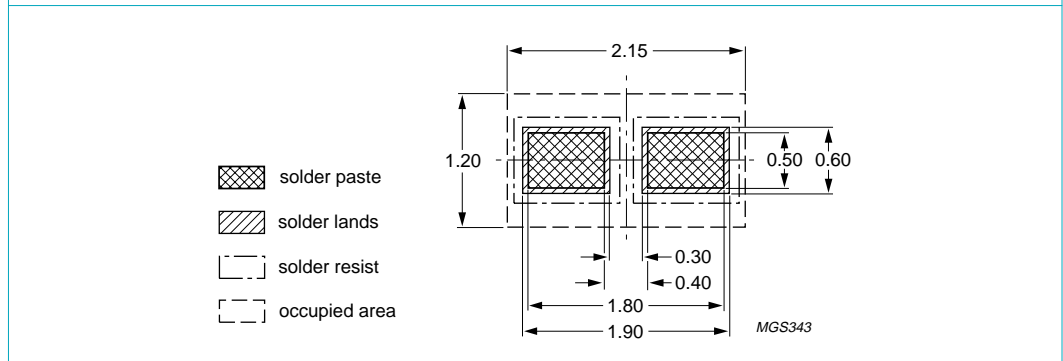

Reflow soldering is the only recommended soldering method.

Dimensions in mm

**Fig 17. Reflow soldering footprint SOD523 (SC-79)**

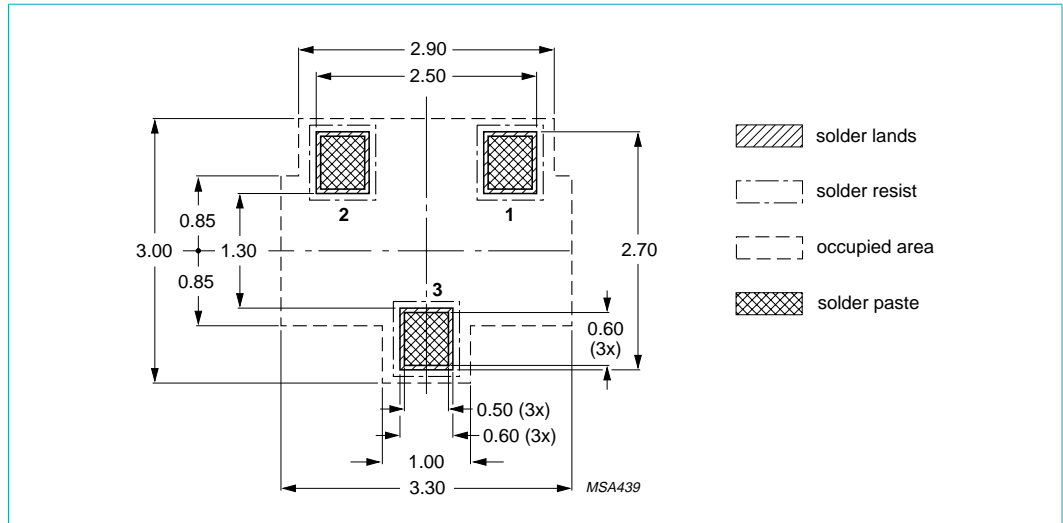

Dimensions in mm

Fig 18. Reflow soldering footprint SOT23 (TO-236AB)

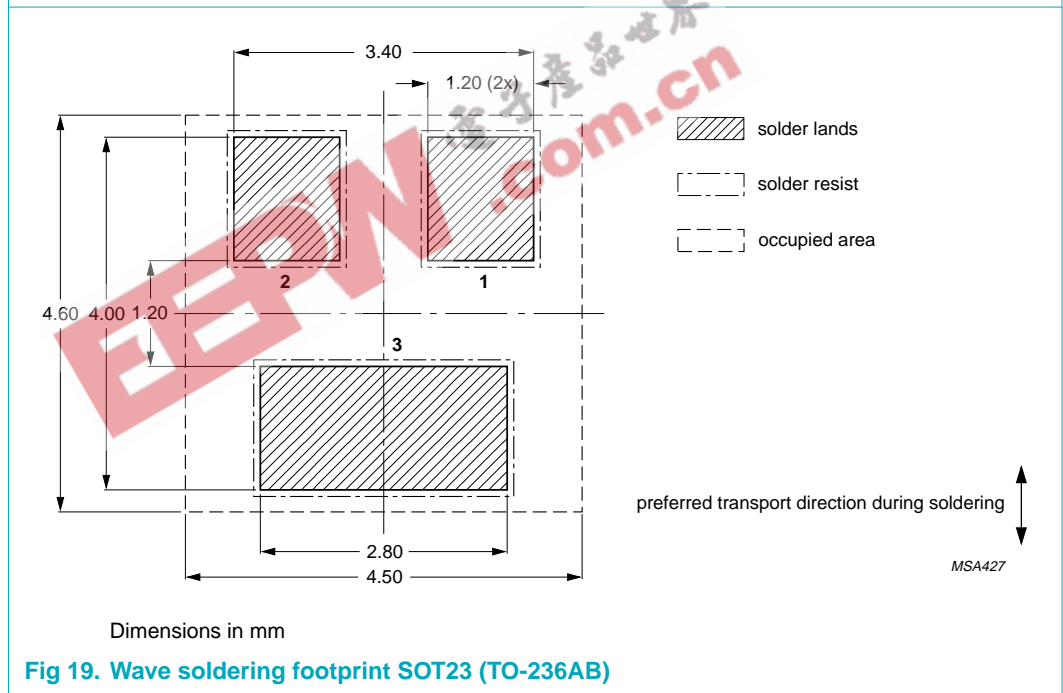

Dimensions in mm

Fig 19. Wave soldering footprint SOT23 (TO-236AB)

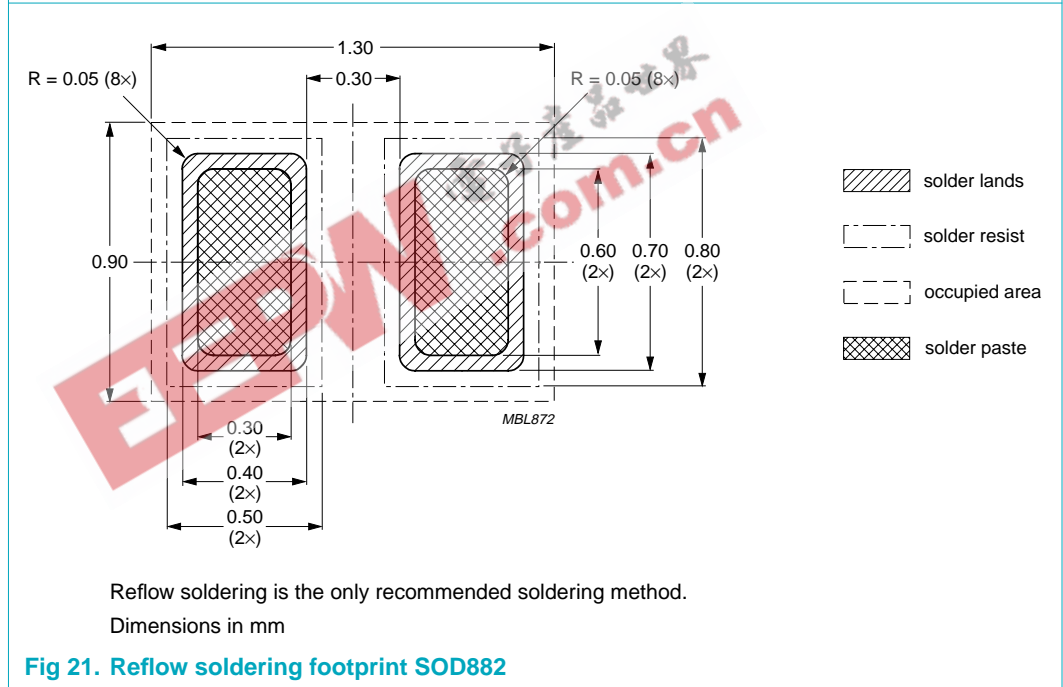
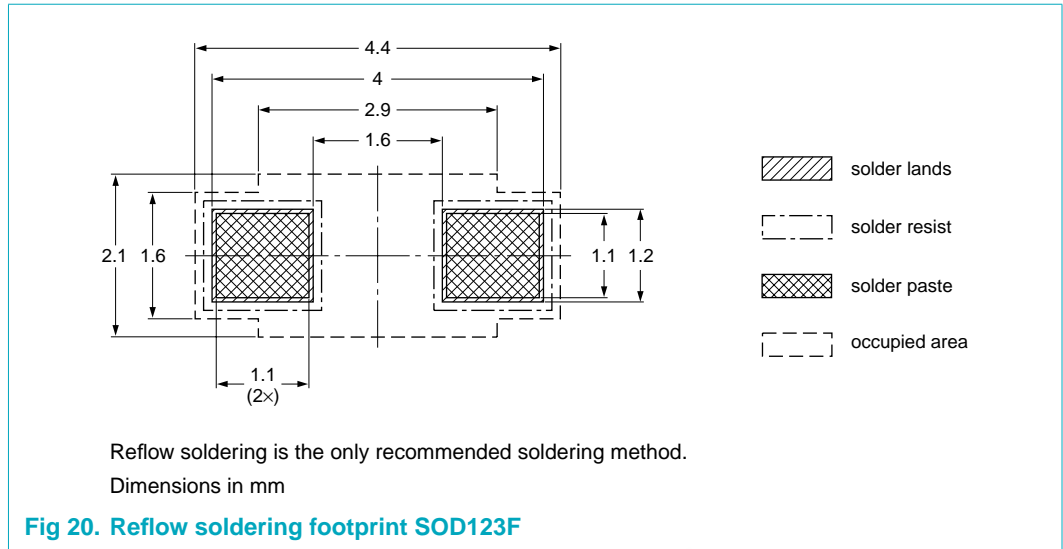

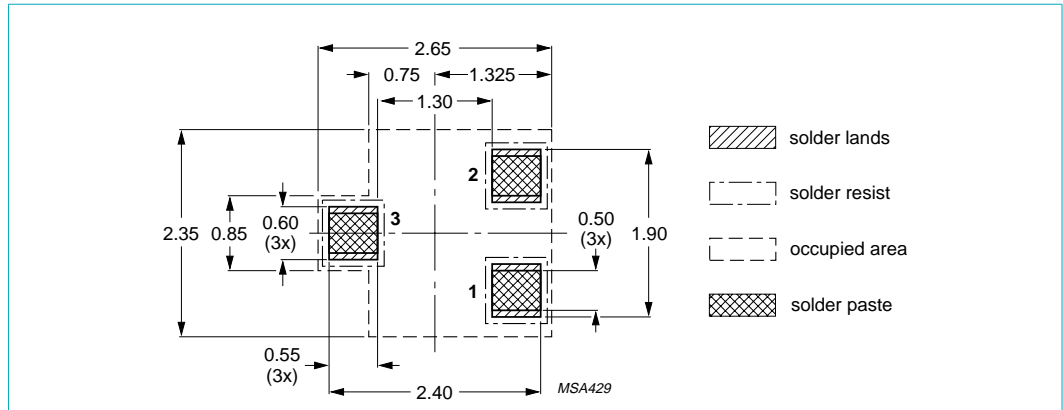

Fig 22. Reflow soldering footprint SOT323 (SC-70)

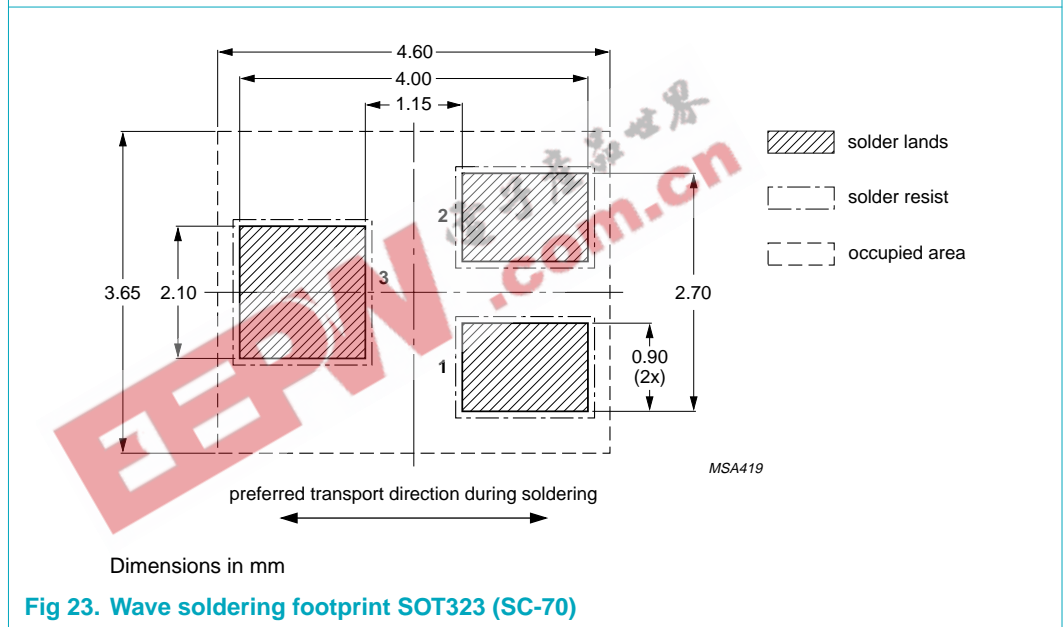
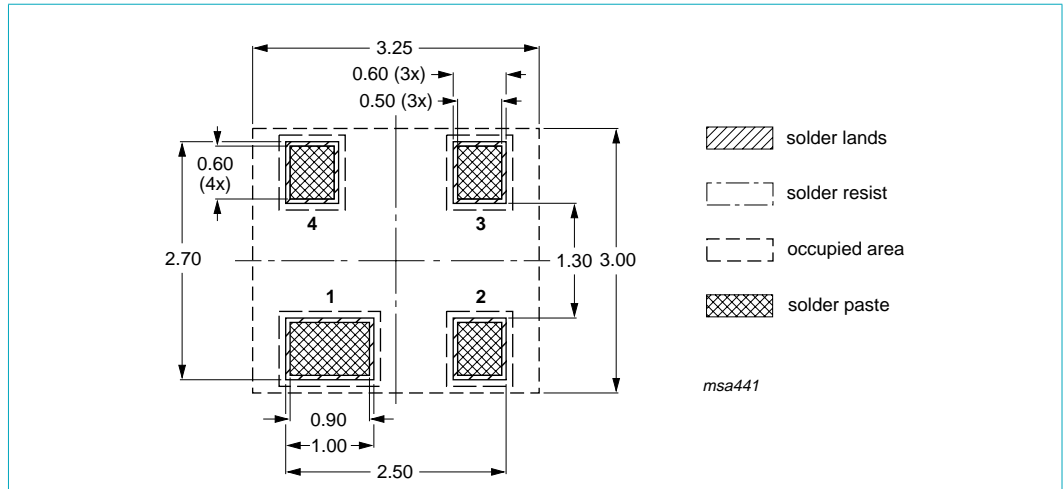
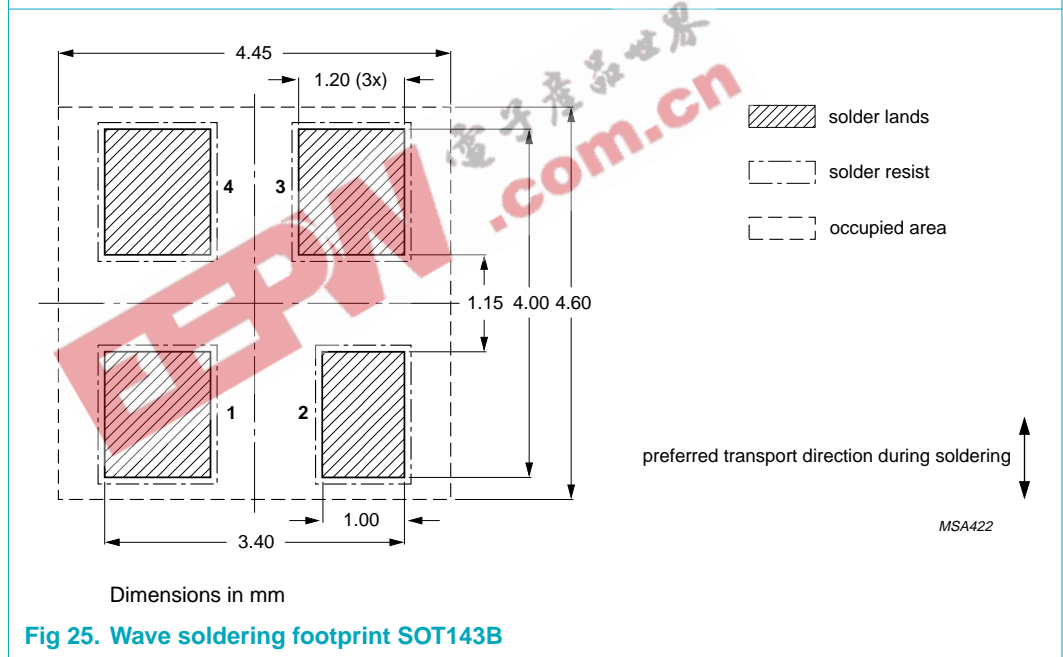

Fig 23. Wave soldering footprint SOT323 (SC-70)



Dimensions in mm

**Fig 24. Reflow soldering footprint SOT143B**



Dimensions in mm

**Fig 25. Wave soldering footprint SOT143B**



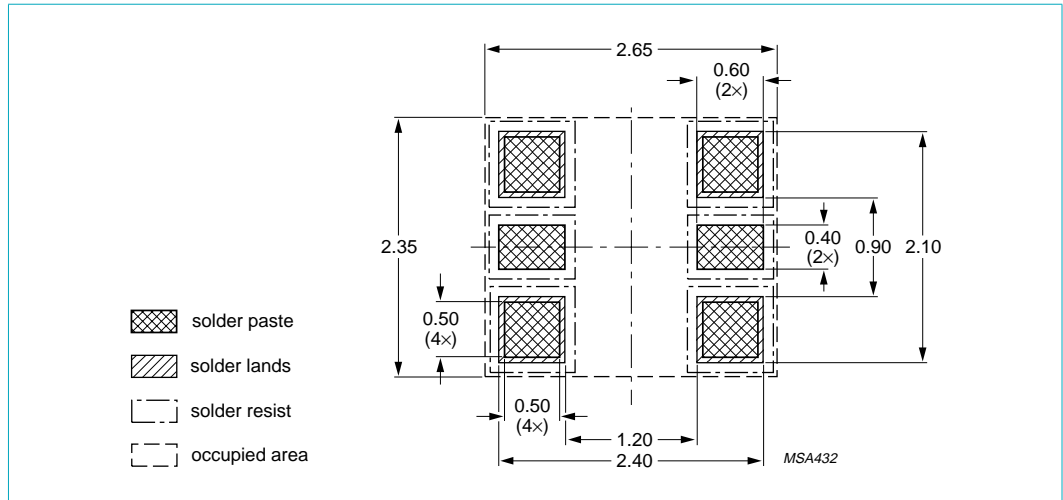

Dimensions in mm

**Fig 26. Reflow soldering footprint SOT363 (SC-88)**

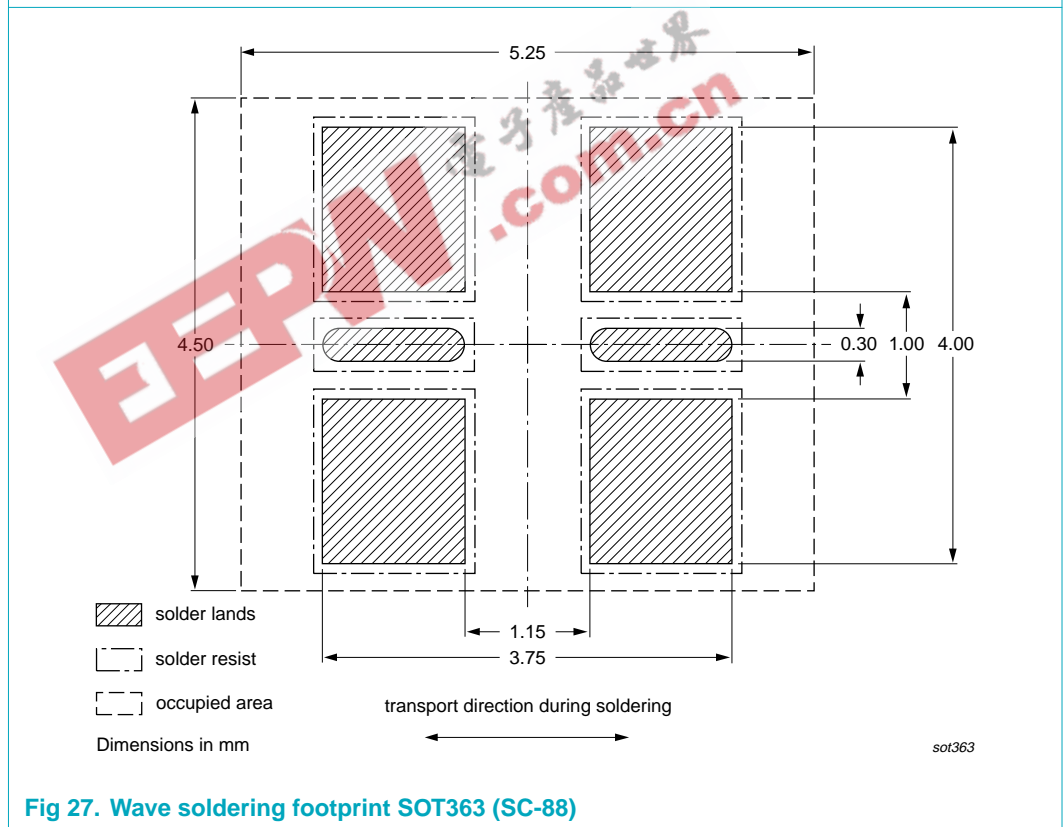

**Fig 27. Wave soldering footprint SOT363 (SC-88)**

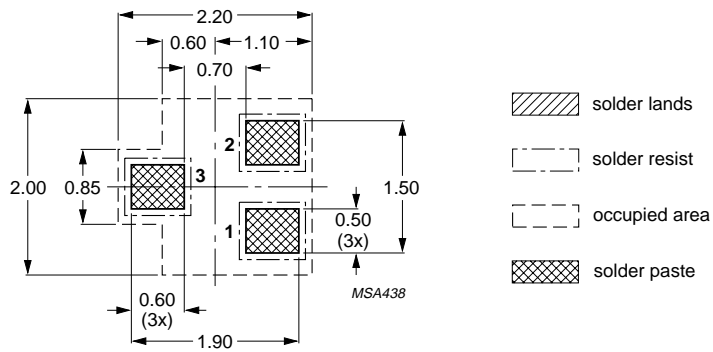
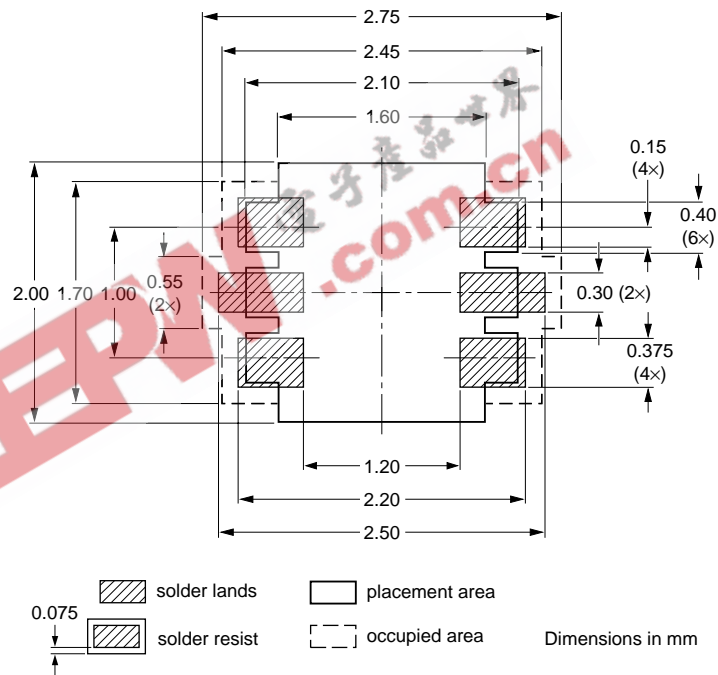

Fig 28. Reflow soldering footprint SOT416



Reflow soldering is the only recommended soldering method.

Fig 29. Reflow soldering footprint SOT666

## 11. Revision history

Table 10. Revision history

Document ID	Release date	Data sheet status	Change notice	Supersedes
BAS40_1PSXXSB4X_SER_7	20060512	Product data sheet	-	BAS40_1PSXXSB4X_SER_6
Modifications:	<ul style="list-style-type: none"> <li>• Type number BAS40XY added</li> <li>• <a href="#">Table 9 "Packing methods"</a>: added packing method 2 mm pitch for SOD523</li> <li>• <a href="#">Figure 27 "Wave soldering footprint SOT363 (SC-88)"</a>: amended</li> <li>• <a href="#">Figure 29 "Reflow soldering footprint SOT666"</a>: amended</li> <li>• <a href="#">Section 12 "Legal information"</a>: updated</li> </ul>			
BAS40_1PSXXSB4X_SER_6	20050809	Product data sheet	-	1PS70SB40_3 1PS75SB45_2 1PS76SB40_3 1PS79SB40_2 1PS88SB48_3 BAS40H_1 BAS40L_1 BAS40-05V_1 BAS40-07V_1 BAS40W_3 BAS40_SERIES_5
1PS70SB40_3	19990426	Product specification	-	1PS70SB40_2
1PS75SB45_2	19990426	Product specification	-	1PS75SB45_1
1PS76SB40_3	20040126	Product specification	-	1PS76SB40_2
1PS79SB40_2	19990426	Product specification	-	1PS79SB40_1
1PS88SB48_3	20021107	Product specification	-	1PS88SB48_2
BAS40H_1	20050425	Product data sheet	-	-
BAS40L_1	20030520	Product specification	-	-
BAS40-05V_1	20021121	Product specification	-	-
BAS40-07V_1	20020327	Product specification	-	-
BAS40W_3	19990426	Product specification	-	BAS40W_2
BAS40_SERIES_5	20011010	Product specification	-	BAS40_4

## 12. Legal information

### 12.1 Data sheet status

Document status <sup>[1][2]</sup>	Product status <sup>[3]</sup>	Definition
Objective [short] data sheet	Development	This document contains data from the objective specification for product development.
Preliminary [short] data sheet	Qualification	This document contains data from the preliminary specification.
Product [short] data sheet	Production	This document contains the product specification.

[1] Please consult the most recently issued document before initiating or completing a design.

[2] The term 'short data sheet' is explained in section "Definitions".

[3] The product status of device(s) described in this document may have changed since this document was published and may differ in case of multiple devices. The latest product status information is available on the Internet at URL <http://www.semiconductors.philips.com>.

### 12.2 Definitions

**Draft** — The document is a draft version only. The content is still under internal review and subject to formal approval, which may result in modifications or additions. Philips Semiconductors does not give any representations or warranties as to the accuracy or completeness of information included herein and shall have no liability for the consequences of use of such information.

**Short data sheet** — A short data sheet is an extract from a full data sheet with the same product type number(s) and title. A short data sheet is intended for quick reference only and should not be relied upon to contain detailed and full information. For detailed and full information see the relevant full data sheet, which is available on request via the local Philips Semiconductors sales office. In case of any inconsistency or conflict with the short data sheet, the full data sheet shall prevail.

### 12.3 Disclaimers

**General** — Information in this document is believed to be accurate and reliable. However, Philips Semiconductors does not give any representations or warranties, expressed or implied, as to the accuracy or completeness of such information and shall have no liability for the consequences of use of such information.

**Right to make changes** — Philips Semiconductors reserves the right to make changes to information published in this document, including without limitation specifications and product descriptions, at any time and without notice. This document supersedes and replaces all information supplied prior to the publication hereof.

**Suitability for use** — Philips Semiconductors products are not designed, authorized or warranted to be suitable for use in medical, military, aircraft, space or life support equipment, nor in applications where failure or

malfunction of a Philips Semiconductors product can reasonably be expected to result in personal injury, death or severe property or environmental damage. Philips Semiconductors accepts no liability for inclusion and/or use of Philips Semiconductors products in such equipment or applications and therefore such inclusion and/or use is for the customer's own risk.

**Applications** — Applications that are described herein for any of these products are for illustrative purposes only. Philips Semiconductors makes no representation or warranty that such applications will be suitable for the specified use without further testing or modification.

**Limiting values** — Stress above one or more limiting values (as defined in the Absolute Maximum Ratings System of IEC 60134) may cause permanent damage to the device. Limiting values are stress ratings only and operation of the device at these or any other conditions above those given in the Characteristics sections of this document is not implied. Exposure to limiting values for extended periods may affect device reliability.

**Terms and conditions of sale** — Philips Semiconductors products are sold subject to the general terms and conditions of commercial sale, as published at <http://www.semiconductors.philips.com/profile/terms>, including those pertaining to warranty, intellectual property rights infringement and limitation of liability, unless explicitly otherwise agreed to in writing by Philips Semiconductors. In case of any inconsistency or conflict between information in this document and such terms and conditions, the latter will prevail.

**No offer to sell or license** — Nothing in this document may be interpreted or construed as an offer to sell products that is open for acceptance or the grant, conveyance or implication of any license under any copyrights, patents or other industrial or intellectual property rights.

### 12.4 Trademarks

Notice: All referenced brands, product names, service names and trademarks are the property of their respective owners.

## 13. Contact information

For additional information, please visit: <http://www.semiconductors.philips.com>

For sales office addresses, send an email to: [sales.addresses@www.semiconductors.philips.com](mailto:sales.addresses@www.semiconductors.philips.com)

**14. Contents**

<b>1</b>	<b>Product profile</b> .....	<b>1</b>
1.1	General description .....	1
1.2	Features .....	2
1.3	Applications .....	2
1.4	Quick reference data .....	2
<b>2</b>	<b>Pinning information</b> .....	<b>2</b>
<b>3</b>	<b>Ordering information</b> .....	<b>5</b>
<b>4</b>	<b>Marking</b> .....	<b>6</b>
<b>5</b>	<b>Limiting values</b> .....	<b>6</b>
<b>6</b>	<b>Thermal characteristics</b> .....	<b>7</b>
<b>7</b>	<b>Characteristics</b> .....	<b>7</b>
<b>8</b>	<b>Package outline</b> .....	<b>9</b>
<b>9</b>	<b>Packing information</b> .....	<b>11</b>
<b>10</b>	<b>Soldering</b> .....	<b>12</b>
<b>11</b>	<b>Revision history</b> .....	<b>19</b>
<b>12</b>	<b>Legal information</b> .....	<b>20</b>
12.1	Data sheet status .....	20
12.2	Definitions .....	20
12.3	Disclaimers .....	20
12.4	Trademarks .....	20
<b>13</b>	<b>Contact information</b> .....	<b>20</b>
<b>14</b>	<b>Contents</b> .....	<b>21</b>

EPW.com.cn 电子产品世界



Please be aware that important notices concerning this document and the product(s) described herein, have been included in section 'Legal information'.

© Koninklijke Philips Electronics N.V. 2006. All rights reserved.

For more information, please visit: <http://www.semiconductors.philips.com>.

For sales office addresses, email to: [sales.addresses@www.semiconductors.philips.com](mailto:sales.addresses@www.semiconductors.philips.com).

Date of release: 12 May 2006

Document identifier: BAS40\_1PSXXSB4X\_SER\_7