



MX23L12811

128M-BIT (8M x 16) MASK ROM WITH PAGE MODE (SOP ONLY)

FEATURES

- Bit organization
 - 8M x 16 (word mode)
- Fast access time
 - Random access: 100ns (max.)
 - Page access: 30ns (max.)
- Page size
 - 8 words per page
- Current
 - Operating:50mA
 - Standby:15uA
- Supply voltage
 - 3.0 ~ 3.6V
- Package
 - 44 pin SOP (500mil)
- Temperature
 - 0~70° C

PIN CONFIGURATION

44 SOP(For Word Mode Only)

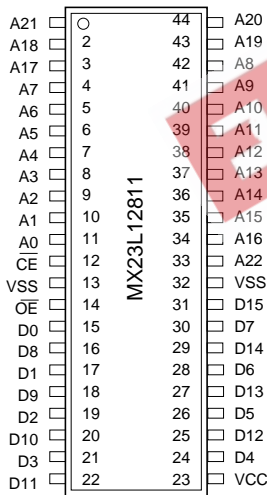

PIN DESCRIPTION

Symbol	Pin Function
A0~A22	Address Inputs
D0~D15	Data Outputs
\overline{CE}	Chip Enable Input
OE	Output Enable Input
VCC	Power Supply Pin
VSS	Ground Pin
NC	No Connection

ORDER INFORMATION

Part No.	Access Time	Page Time	Package	Note
MX23L12811MC-12	120ns	50ns	44 pin SOP	
MX23L12811MC-10	100ns	30ns	44 pin SOP	



ABSOLUTE MAXIMUM RATINGS

Item	Symbol	Ratings
Voltage on any Pin Relative to VSS	VIN	-1.3V to VCC+2.0V (Note)
Ambient Operating Temperature	Topr	0° C to 70° C
Storage Temperature	Tstg	-65° C to 125° C

Note: Minimum DC voltage on input or I/O pins is -0.5V. During voltage transitions, inputs may undershoot VSS to -1.3V for periods of up to 20ns. Maximum DC voltage on input or I/O pins is VCC+0.5V. During voltage transitions, inputs may overshoot VCC to VCC+2.0V for periods of up to 20ns.

DC CHARACTERISTICS (Ta = 0° C ~ 70° C, VCC = 3.0~3.6V)

Item	Symbol	MIN.	MAX.	Conditions
Output High Voltage	VOH	2.4V	-	IOH = -0.4mA
Output Low Voltage	VOL	-	0.4V	IOL = 1.6mA
Input High Voltage	VIH	2.2V	VCC+0.3V	
Input Low Voltage	VIL	-0.3V	0.2 x VCC	
Input Leakage Current	ILI	-	5uA	0V, VCC
Output Leakage Current	ILO	-	5uA	0V, VCC
Operating Current	ICC1	-	50mA	f=5MHz, all outputs open
Standby Current (TTL)	ISTB1	-	1mA	CE = VIH
Standby Current (CMOS)	ISTB2	-	15uA	CE > VCC-0.2V
Input Capacitance	CIN	-	10pF	Ta = 25° C, f = 1MHZ
Output Capacitance	COUT	-	10pF	Ta = 25° C, f = 1MHZ

AC CHARACTERISTICS (Ta = 0° C ~ 70° C, VCC = 3.0~3.6V)

Item	Symbol	23L12811-10		23L12811-12	
		MIN.	MAX.	MIN.	MAX.
Read Cycle Time	tRC	100ns	-	120ns	-
Address Access Time	tAA	-	100ns	-	120ns
Chip Enable Access Time	tACE	-	100ns	-	120ns
Page Mode Access Time	tPA	-	30ns	-	50ns
Output Enable Time	tOE	-	30ns	-	50ns
Output Hold After Address	tOH	0ns	-	0ns	-
Output High Z Delay	tHZ	-	20ns	-	20ns

Note:

1. Output high-impedance delay (tHZ) is measured from \overline{OE} or \overline{CE} going high, and this parameter guaranteed by design over the full voltage and temperature operating range - not tested.

AC Test Conditions

Input Pulse Levels	0.4V~2.4V
Input Rise and Fall Times	10ns
Input Timing Level	1.4V
Output Timing Level	1.4V
Output Load	See Figure

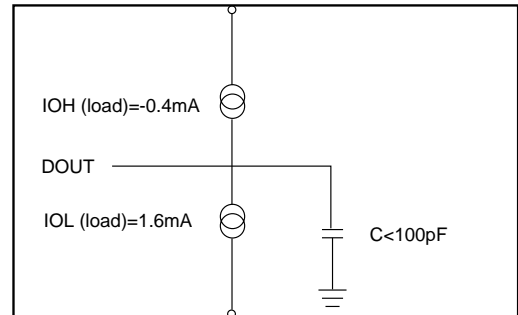

Note: No output loading is present in tester load board.
 Active loading is used and under software programming control.
 Output loading capacitance includes load board's and all stray capacitance.

TIMING DIAGRAM

RANDOM READ

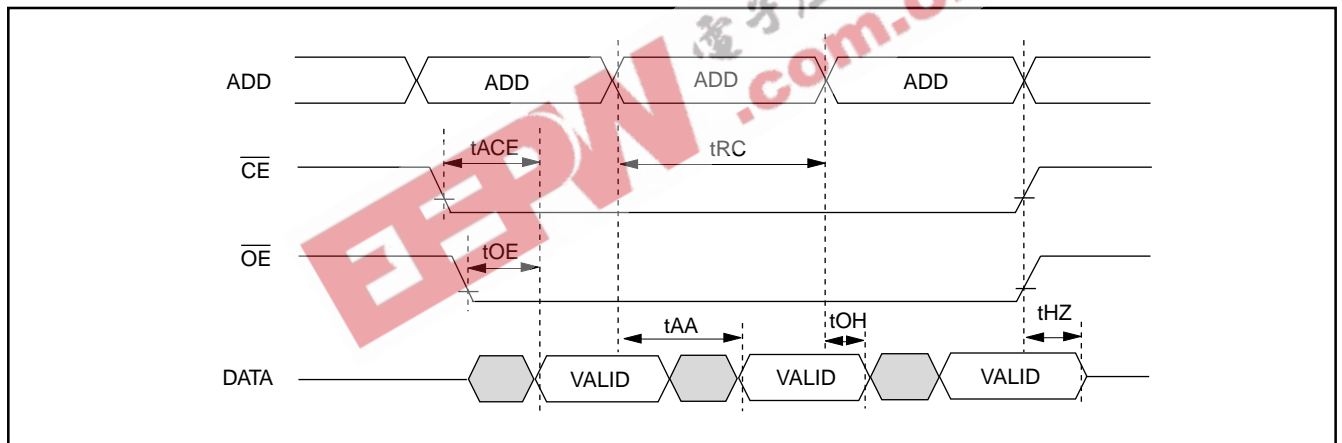

PAGE READ

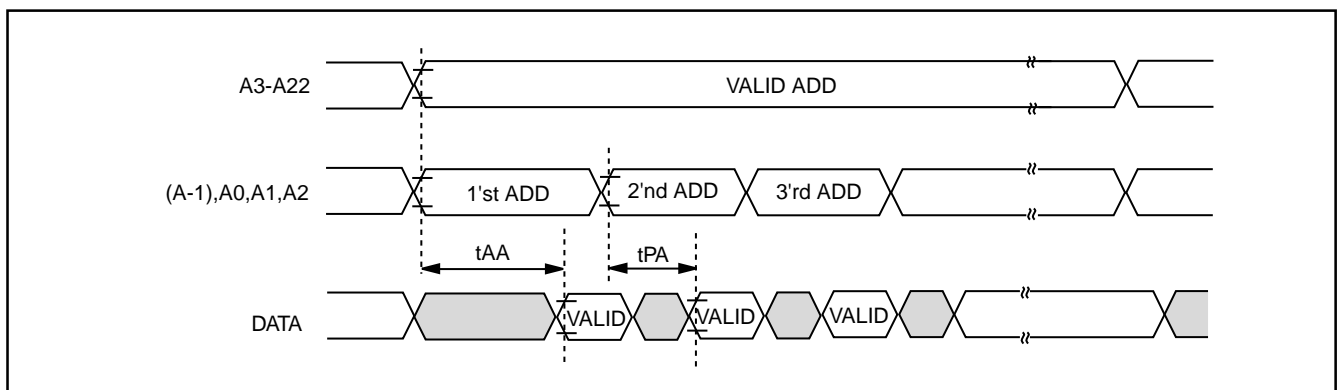

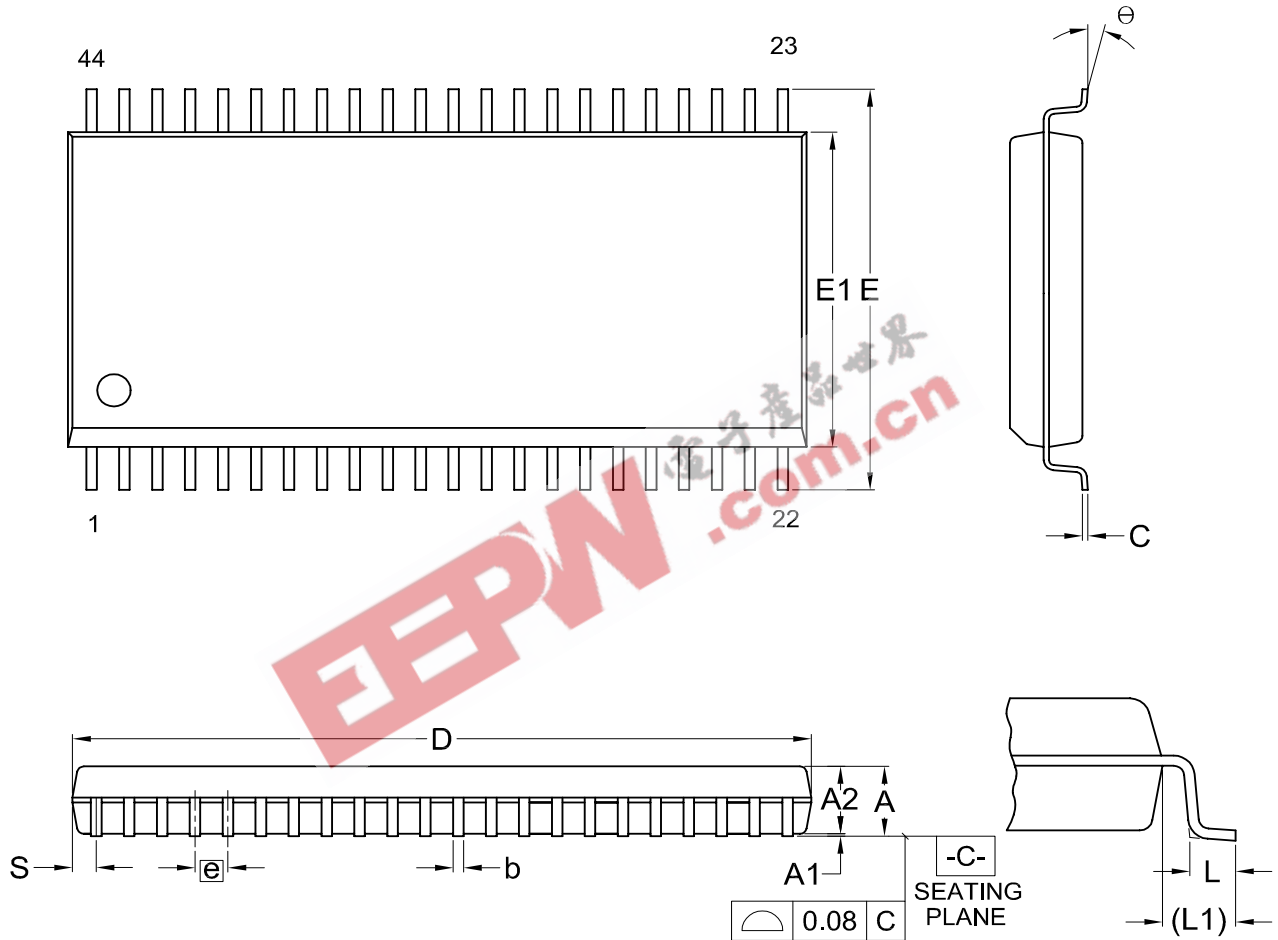
PACKAGE INFORMATION
Title: Package Outline for SOP 44L (500MIL)

Dimensions (inch dimensions are derived from the original mm dimensions)

SYMBOL		A	A1	A2	b	C	D	E	E1	e	L	L1	S	θ
UNIT														
mm	Min.	---	0.10	2.59	0.36	0.15	28.37	15.83	12.47		0.56	1.51	0.78	0
	Nom.	---	0.15	2.69	0.41	0.20	28.50	16.03	12.60	1.27	0.76	1.71	0.91	5
	Max.	3.00	0.20	2.80	0.51	0.25	28.63	16.23	12.73		0.96	1.91	1.04	10
Inch	Min.	---	0.004	0.102	0.014	0.006	1.117	0.623	0.491		0.022	0.059	0.031	0
	Nom.	---	0.006	0.106	0.016	0.008	1.122	0.631	0.496	0.050	0.030	0.067	0.036	5
	Max.	0.118	0.008	0.110	0.020	0.010	1.127	0.639	0.501		0.038	0.075	0.041	10

DWG.NO.	REVISION	REFERENCE			ISSUE DATE
		JEDEC	EIAJ		
6110-1405	6	MO-175			11-26-03

REVISION HISTORY

Revision #	Description	Page	Date
1.1	Add Order Information	P1	JUL/27/2000
1.2	Modify Order Information/AC Characteristics MX23L12811MC-12-->13	P1,2	SEP/07/2000
1.3	Add Order Information--MX23L12811MC-12	P1,2	SEP/21/2000
1.4	Delete Order Information--MX23L12811MC-13	P1,2	OCT/03/2000
1.5	Modify Current Operating:60mA-->40mA	P1	DEC/12/2000
	Modify ICC1:60mA-->40mA, f=5MHz, all outputs open	P2	
	Delete ICC2	P2	
1.6	Modify Current Operating:40mA-->50mA	P1	DEC/14/2000
	Modify ICC1:40mA-->50mA	P2	
1.7	Add 90ns access time	P1,2	AUG/22/2001
	Change Supply voltage:3.4V±0.2-->3.0~3.6V	P1,2	
	Add Temperature:0~70° C	P1	
	Change Input Pulse Levels:0.3V~3.0V-->0.4V~2.4V	P3	
1.8	Add 100ns access time	P1,2	AUG/28/2001
1.9	Modify MX23L12811MC-12 speed-->130ns; Supply voltage-->3.2~3.6V	P1,2	SEP/19/2001
2.0	To modify Package Information	P4	NOV/20/2002
2.1	1. Removed access time:90ns	P1,2	FEB/17/2005

EEPW.com.cn 电子产业世界



MX23L12811

MACRONIX INTERNATIONAL CO., LTD.

Headquarters:

TEL:+886-3-578-6688

FAX:+886-3-563-2888

Europe Office :

TEL:+32-2-456-8020

FAX:+32-2-456-8021

Hong Kong Office :

TEL:+86-755-834-335-79

FAX:+86-755-834-380-78

Japan Office :

Kawasaki Office :

TEL:+81-44-246-9100

FAX:+81-44-246-9105

Osaka Office :

TEL:+81-6-4807-5460

FAX:+81-6-4807-5461

Singapore Office :

TEL:+65-6346-5505

FAX:+65-6348-8096

Taipei Office :

TEL:+886-2-2509-3300

FAX:+886-2-2509-2200

MACRONIX AMERICA, INC.

TEL:+1-408-262-8887

FAX:+1-408-262-8810

<http://www.macronix.com>
